

UPRIGHT, PENDENT AND RECESSED PENDENT SPRINKLER (STANDARD & QUICK RESPONSE)



TECHNICAL DATA

Style	Upright, Pendent and Recessed Pendent
Temperature Response	Standard Response - 5mm glass bulb Quick Response - 3mm glass bulb
Coverage	Standard Coverage
K-Factor	5.6 US (80 metric)
Nominal Thread Size	1/2" BSPT (NPT Optional)
Max. Working Pressure	175 PSI (12 Bar)
Factory Hydrostatic Test Pressure	500 PSI (35 Bar)
Min. Operating Pressure	7 PSI (0.5 Bar)
Temp. Rating	57°C (135° F), 68°C (155° F), 79°C (175° F), 93°C (200° F)
Approvals	Refer Table - 1
Finish	Brass, Chrome Plated, White Painted
Ordering Information	Style, Temp. Rating & Response, Thread type, Finish, Approval required - UL or UL & FM
SIN Number	HD101 - Pendent, SR HD102 - Upright, SR HD201 - Pendent, QR HD202 - Upright, QR

Note: Standard supply is with UL Listing only. If UL & FM approval is required, then please specify in your order with item code number as in Table 1, or contact our sales team.

DESCRIPTION

Pendent & Upright Sprinklers

HD Pendent and Upright sprinklers are designed for use in light and ordinary hazards. The temperature response is standard response (5 mm glass bulb) and quick response (3mm glass bulb). The sprinklers come with compact design, glass bulb type, available in several different finishes and temperature ratings. The pendent sprinklers must be installed in pendent position, and upright sprinklers are to be installed in the upright position.



APPROVALS

Response Type	Type	Temp Rating	Listing	
			Code No for UL	Code No for UL & FM
SR	PENDENT	57°C (135°F)	T10021	T10021F
		68°C (155°F)	T10022	T10022F
		79°C (175°F)	T10023	T10023F
		93°C (200°F)	T10024	T10024F
SR	UPRIGHT	57°C (135°F)	T10055	T10055F
		68°C (155°F)	T10056	T10056F
		79°C (175°F)	T10057	T10057F
		93°C (200°F)	T10058	T10058F
QR	PENDENT	57°C (135°F)	T10001	-
		68°C (155°F)	T10002	T10002F
		79°C (175°F)	T10003	T10003F
		93°C (200°F)	T10004	T10004F
QR	UPRIGHT	57°C (135°F)	T10041	-
		68°C (155°F)	T10042	T10042F
		79°C (175°F)	T10043	T10043F
		93°C (200°F)	T10044	T10044F

Table 1

Pendent Recessed Sprinklers are installed with adjustable or non-adjustable Escutcheon plates (also termed as Rosette plates). These are intended to be installed with finished ceilings. Escutcheon plate adjustment provides convenience in Pendent Sprinkler installation in case of areas with finished ceilings or walls.

Sprinkler Operation

The Sprinkler operating device is state of the art heat responsive frangible glass bulb supplied by a world leader in this innovative technology. The glass bulb contains fluid which expands when exposed to heat.

When rated temperature is reached, the bulb shatters and water flows through the sprinkler and strikes deflector, forming a uniform water spray pattern to control or extinguish fire.

Care and Handling

Sprinklers must be handled with due care, they must be stored at ambient temperature for best results. Storage as well as any onward shipment is to be made in original packing only. Sprinklers must be visually inspected carefully before installation. Sprinklers visibly damaged, dropped or exposed to temperature in excess of the maximum ambient temperature permitted, should never be installed. Never install any glass bulb sprinkler if the bulb is cracked or if there is a loss of liquid from the bulb. Sprinkler must be installed after the piping is in place to prevent mechanical damage.

Use Teflon Tape or soft thread sealant on male thread of the Sprinkler for the leak tight Sprinkler joint. Use proper wrench and appropriate torque. Excessive tightening torque may distort the Sprinkler inlet and cause leakage. Sprinkler must never be painted, plated or coated after they leave factory.

The HD Sprinkler described herein must be installed and maintained in accordance with the latest edition of HD technical data, the latest standard of National Fire protection Association (NFPA) and Factory Mutual (FM) or to the standard of any other authorities having jurisdiction. The owner is solely responsible for maintaining their fire protection system and device in proper operating condition.

Inspection Testing and Maintenance

Refer to NFPA 25 for inspection testing and maintenance requirement or to the authority having jurisdiction. For details of warranty, refer HD's current price list, conditions of sale or contact HD directly.

Material Specification	
Deflector	Brass
Bulb	Glass
Load Screw	Brass
Cap	Copper
Frame	Brass
Seal	Belleville Washer coated on both sides with Teflon Tape
Bulb Nominal Diameter	Standard Response 5.0mm Quick Response 3.0mm

SPRINKLER RATINGS

SPRINKLER TEMP. CLASSIFICATION	NORMAL SPRINKLER TEMP. RATING	NFPA MAX. CEILING TEMP. ALLOWED	GLASS BULB COLOUR
Ordinary	57° C (135° F)	38° C (100° F)	Orange
Ordinary	68° C (155° F)	38° C (100° F)	Red
Intermediate	79° C (175° F)	65° C (150° F)	Yellow
Intermediate	93° C (200° F)	65° C (150° F)	Green

PENDENT & UPRIGHT SPRINKLER

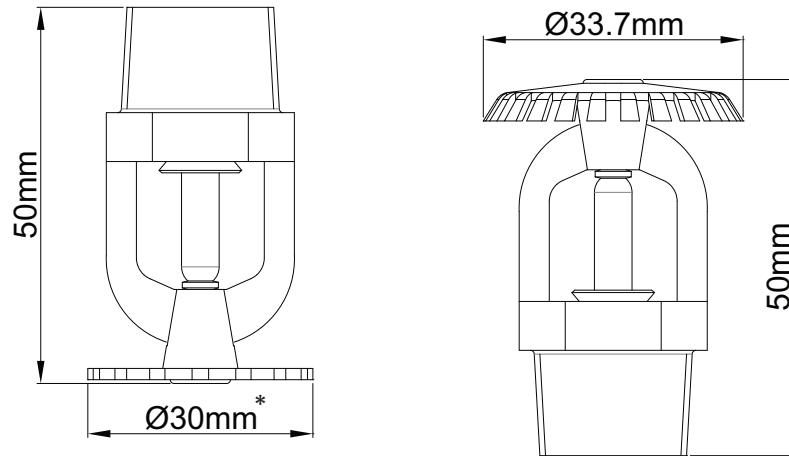

* For T10002F/ T10003F/ T10004F Deflector diameter is 25 mm.

RECESSED PENDENT

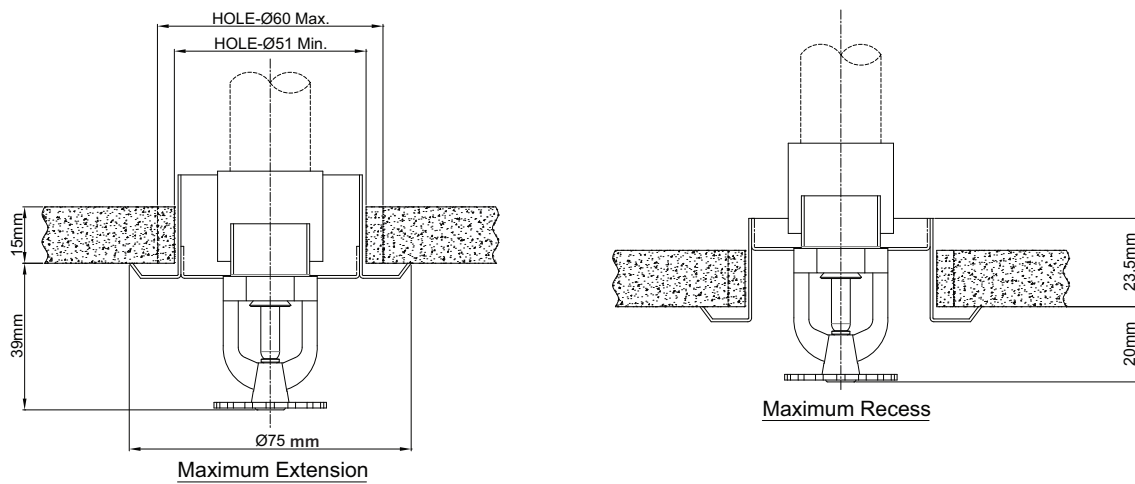

LIMITED WARRANTY

HD FIRE PROTECT PVT. LTD. hereby referred to as HD FIRE warrants to the original purchaser of the fire protection products manufactured by HD FIRE and to any other person to whom such equipment is transferred, that such products will be free from defect in material and workmanship under normal use and care, for two (2) years from the date of shipment by HD FIRE. Products or Components supplied or used by HD FIRE, but manufactured by others, are warranted only to the extent of the manufacturer's warranty. No warranty is given for product or components which have been subject to misuse, improper installation, corrosion, unauthorized repair, alteration or un-maintained. HD FIRE shall not be responsible for system design errors or improper installation or inaccurate or incomplete information supplied by buyer or buyer's representatives. HD FIRE will repair or replace defective material free of charge, which is returned to our factory, transportation charge prepaid, provided after our inspection the material is found to have been defective at the time of initial shipment from our works. HD FIRE shall not be liable for any incidental or consequential loss, damage or expense arising directly or indirectly from the use of the product including damages for injury to person, damages to property and penalties resulting from any products and components manufactured by HD FIRE. HD FIRE shall not be liable for any damages or labour charges or expense in making repair or adjustment to the product. HD FIRE shall not be liable for any damages or charges sustained in the adaptation or use of its engineering data & services. In no event shall HD Fire's product liability exceed an amount equal to the sale price. The foregoing warranty is exclusive and in lieu of all other warranties and representation whether expressed, implied, oral or written, including but not limited to, any implied warranties or merchantability or fitness for a particular purpose. All such other warranties and representations are hereby cancelled.

NOTICE :

The equipment presented in this bulletin is to be installed in accordance with the latest publication standards of NFPA or other similar organisations and also with the provision of government codes or ordinances wherever applicable.

The information provided by us is to the best of our knowledge and belief, and consist of general guidelines only. Site handling and installation control is not in our scope. Hence we give no guarantee for result and take no liability for damages, loss or penalties whatsoever, resulting from our suggestion, information, recommendation or damages due to our product.

Product development is a continuous programme of HD FIRE PROTECT PVT. LTD. and hence the right to modify any specification without prior notice is reserved with the company.



HD FIRE PROTECT PVT. LTD.
Protecting What Matters Most to You

D-6/2, ROAD NO. 34, WAGLE INDUSTRIAL ESTATE, THANE 400 604, INDIA.
• TEL: + (91) 22 2158 2600 • FAX: +(91) 22 2158 2602
• EMAIL: info@hdfire.com • WEB: www.hdfire.com