

Instructions

Eagle Quantum Premier® Fire and Gas Detection/Releasing System



Table of Contents

Section 1 - Safety

ALERT MESSAGES.....	1-1
---------------------	-----

Section 2 - Introduction

SYSTEM DESCRIPTION	2-1
Communications Loop	2-1
LON Communication Heartbeat.....	2-2
Theory of Operation	2-3
Controller Logs	2-4
Controller User Logic	2-4
Communication Network Fault Operation	2-5
Multiple Wiring Faults	2-5
MAJOR COMPONENT DESCRIPTIONS.....	2-6
System Controller	2-6
Controller Redundancy	2-6
Ethernet Interface Board	2-7
Serial Interface Board	2-7
ControlNet Board or Ethernet DLR Board	2-7
Controller-to-Controller Communication	2-8
EQP Supervising System.....	2-8
EQP Marine Application System	2-8
Local Operating Network (LON).....	2-8
Network Extenders	2-8
EQ21xxPS Series Power Supplies and EQ2100PSM Power Supply Monitor	2-9
EQP21xxPS(-X) Power Supplies and EQP2410PS(-P) Converter.....	2-9
EQ2220GFM Ground Fault Monitor.....	2-9
Field Devices.....	2-9
Flame Detectors	2-9
EQ3730EDIO Enhanced Discrete I/O Module	2-9
EQ3700 8 Channel DCIO Module	2-10
EQ3720 8 Channel Relay Module.....	2-11
EQ3710AIM Analog Input Module.....	2-11
EQ3750ASH Addressable Smoke & Heat Module.....	2-12
EQ25xxARM Agent Release Module.....	2-13
EQ25xxSAM Signal Audible Module.....	2-14
EQ22xxIDC Series Initiating Device Circuit.....	2-14
EQ22xxDCU / EQ22xxDCUJEX Digital Communication Units	2-15
PIRECL PointWatch Eclipse	2-15
OPECL Open Path Eclipse.....	2-15
UD10 DCU Emulator	2-15

Section 3 - Installation

SAFETY SYSTEM DESIGN REQUIREMENTS.....	3-1
Identifying the Area of Protection	3-1
Identifying Wiring, Network (LON), and System Power Requirements	3-1
General Wiring Requirements	3-1
Power Wiring	3-1
System Wiring (ATEX and IECEx).....	3-1
Determining Power Requirements.....	3-3
EQ211xPS, EQ213xPS and EQ217xPS Power Supplies	3-5
Backup Battery.....	3-5
Battery Charger.....	3-5
EQP21x0PS(-X) Power Supplies.....	3-5
EQP2410PS(-P) Converter	3-6
Determining Power Requirements.....	3-6
Shield Grounding	3-7
Junction Box Grounding.....	3-7
Response Time vs. System Size	3-7
Moisture Damage Protection	3-7
Electrostatic Discharge	3-7
GROUND FAULT MONITOR (GFM) INSTALLATION.....	3-8
Mounting.....	3-8
Wiring	3-8
NETWORK & NETWORK EXTENDER INSTALLATION...3-8	
Mounting.....	3-8
Wiring	3-8
INITIATING DEVICE CIRCUIT (IDC) INSTALLATION	3-11
EQ22xxIDC Series Initiating Device Circuit.....	3-11
Mounting	3-11
Wiring	3-11
EQ22xxIDCGF Series Initiating Device Circuit Ground Fault	3-12
Mounting	3-12
Wiring	3-12
EQ22xxIDCS Series Initiating Device Circuit Short Circuit	3-13
Mounting	3-13
Wiring	3-13

Table of Contents – Continued

EQ3XXX CONTROLLER INSTALLATION	3-13	8 CHANNEL RELAY MODULE INSTALLATION.....	3-41
Enclosure Requirements	3-13	Mounting.....	3-41
Mounting.....	3-14	Wiring	3-41
Serial Interface Board.....	3-14	Configuration	3-42
Ethernet Interface Board.....	3-14	ANALOG INPUT MODULE INSTALLATION	3-43
Wiring	3-14	Mounting.....	3-43
Power Wiring	3-14	Wiring	3-43
Electrical Connections	3-14	Configuration	3-44
Controller to Controller Communication	3-19	GAS DETECTOR LOCATION AND INSTALLATION	3-45
Configuration.....	3-23	Environments and Substances that Affect	
Software Defined Addresses.....	3-23	Gas Detector Performance	3-46
EQ3XXX REDUNDANT CONTROLLER		EQ22xxDCU Digital Communication Unit used with	
INSTALLATION	3-25	Det-Tronics H2S/O2 Sensors or other Two-Wire	
Enclosure Requirements	3-25	4-20 mA Devices	3-47
Mounting.....	3-25	Assembly and Wiring Procedure.....	3-47
Wiring	3-25	Sensor Separation for DCU with H2S and O2	
LON Wiring.....	3-25	Sensors.....	3-47
High Speed Serial Link (HSSL)	3-26	EQ22xxDCU Digital Communication Unit used with	
Configuration.....	3-26	PointWatch/DuctWatch.....	3-48
S ² Configuration.....	3-26	Assembly and Wiring Procedure.....	3-48
Controller Addresses.....	3-26	Sensor Separation for DCU with PointWatch	3-49
RS485/RS232	3-26	EQ22xxDCU EX Digital Communication Unit (used with	
ControlNet.....	3-26	Det-Tronics Combustible Gas Sensors)	3-49
Ethernet DLR.....	3-26	Mounting	3-49
Ethernet.....	3-26	Wiring	3-49
EQ21XXPS SERIES POWER SUPPLY AND		Sensor Separation with DCU EX	3-51
POWER SUPPLY MONITOR INSTALLATION.....	3-26	EQ25xxARM Series Agent Release Module.....	3-52
Mounting.....	3-27	Mounting	3-52
Wiring	3-27	Wiring	3-52
Startup.....	3-27	Supervised Output for Deluge and Pre-action	3-53
Measuring Battery Voltage and Charging Current	3-28	Jumpers	3-54
EQP2XX0PS(-X) POWER SUPPLIES AND		Address Setting.....	3-54
REDUNDANCY MODULE INSTALLATION	3-29	EQ25xxSAM Series Signal Audible Module	3-54
Mounting.....	3-29	Mounting	3-54
Wiring	3-29	Wiring	3-54
Startup.....	3-32	Jumpers	3-55
EDIO MODULE INSTALLATION.....	3-32	Address Setting.....	3-55
Configuration.....	3-36	SYSTEM CONFIGURATION	3-56
8 CHANNEL DCIO INSTALLATION	3-37	Setting Device Network addresses	3-56
Mounting.....	3-37	Overview of Network Addresses	3-56
Wiring	3-37	Setting Field Device Addresses	3-56
Configuration.....	3-41	TYPICAL APPLICATIONS.....	3-56

Table of Contents – Continued

Section 4 - Operation

SYSTEM CONTROLLER.....	4-1	EQ21XXPSM POWER SUPPLY MONITOR.....	4-15
Pushbuttons.....	4-1	EQ2220GFM GROUND FAULT MONITOR.....	4-15
Controller Status Indicators.....	4-2	EQ22XXIDC SERIES INITIATING DEVICE CIRCUIT	4-16
Text Display.....	4-2	EQ22XXDCU AND EQ22XXDCUEX DIGITAL	
Controller Menu Options.....	4-2	COMMUNICATION UNITS.....	4-16
Controller Audible Alarm.....	4-6	EQ25XXARM AGENT RELEASE MODULE.....	4-17
ControlNet Status Indicators (Optional).....	4-7	EQ25XXSAM SIGNAL AUDIBLE MODULE.....	4-17
Ethernet DLR Status Indicators.....	4-7	EQ24XXNE NETWORK EXTENDER.....	4-17
Sequence of Events During a Configuration		SYSTEM STARTUP.....	4-18
Data Download.....	4-8	Pre-Operation Checks.....	4-18
Controller Redundancy.....	4-9	General Start-up Procedures.....	4-19
ENHANCED DISCRETE I/O MODULE.....	4-11	Startup Procedure for Controller.....	4-20
Power-Up Sequence.....	4-11	Startup Procedure for EDIO Module.....	4-20
8 CHANNEL DCIO MODULE.....	4-12	Startup Procedure for DCIO Module.....	4-21
Power-Up Sequence.....	4-12		
8 CHANNEL RELAY MODULE.....	4-13		
Power-Up Sequence.....	4-13		
ANALOG INPUT MODULE.....	4-14		
Power-Up Sequence.....	4-14		

Table of Contents – Continued

Section 5 - Maintenance

ROUTINE MAINTENANCE	5-1
Batteries	5-1
Manual Check of Output Devices	5-1
O-Ring Maintenance	5-1
GAS SENSOR MAINTENANCE	5-1
CALIBRATION AND ADJUSTMENTS	5-2
Calibration Algorithm A For Manual Calibration of Universal DCU	5-2
Normal Calibration	5-2
Sensor Replacement	5-3
Calibration Algorithm C For Combustible Gas DCUs and Automatic Calibration of Universal DCUs	5-3
Routine Calibration	5-3
Initial Installation and Sensor Replacement — Combustible Gas	5-4
Sensor Replacement — Toxic Gas	5-5
Calibration Algorithm D For Universal DCUs with O2 Sensor	5-5
Normal Calibration	5-5
Sensor Replacement	5-5
Calibration Algorithm G For DCUs with PointWatch or DuctWatch	5-6
Routine Calibration	5-6
Sensor Replacement	5-6
DEVICE CALIBRATION LOGS AND RECORDS	5-7
TROUBLESHOOTING	5-7
REPLACEMENT PARTS	5-7
DEVICE REPAIR AND RETURN	5-7
ORDERING INFORMATION	5-9
Power Supplies	5-9
LON Devices	5-9
Redundancy	5-9
Controller Communication Cables	5-9

Section 6 - Specifications

EQ3XXX Controller	6-1
EQ3LTM LON Termination Module	6-3
EQ3730EDIO Enhanced Discrete I/O Module	6-3
EQ3700 DCIO Module	6-5
EQ3720 Relay Module	6-7
EQ3710AIM Analog Input Module	6-7
HART Interface Module	6-8
EQ21xxPS Power Supplies	6-8
EQP2xx0PS(-x) Power Supplies	6-9
Redundancy Module Quint-Diode/40	6-9
EQ21xxPSM Power Supply Monitor	6-10
EQ22xxIDC Series Initiating Device Circuit	6-10
EQ2220GFM Ground Fault Monitor	6-11
EQ22xxDCU Series Digital Communication Unit	6-12
EQ25xxARM Agent Release Module	6-13
EQ25xxSAM Signal Audible Module	6-14
EQ24xxNE Network Extender	6-15
EQ3750ASH Addressable Smoke & Heat Module	6-16
Combustible Gas Sensor	6-16
Electrochemical Sensors	6-16
EQ21xxPS Power Supply	6-16

Appendix

APPENDIX A — FM APPROVAL DESCRIP.	A-1
APPENDIX B — CSA CERTIFICATION DESCRIP.	B-1
APPENDIX C — ATEX AND IECEx CERTIFICATION ..	C-1
APPENDIX D — EQP MARINE, USCG APPROVAL	D-1
APPENDIX E — CE MARK	E-1
APPENDIX F — ROCKER SWITCH TABLE	F-1
APPENDIX G — DEVICE MODEL MATRICES	G-1

Eagle Quantum Premier®
Fire and Gas Detection/
Releasing System

Section 1
Safety

ALERT MESSAGES

The following Alert Messages, **DANGER**, **WARNING**, **CAUTION**, and **IMPORTANT** are used throughout this manual and on the system to alert the reader and operator to dangerous conditions and/or important operational or maintenance information.



*Identifies immediate hazards that **WILL** result in severe personal injury or death.*



*Identifies hazards or unsafe practices that **COULD** result in severe personal injury or death.*



*Identifies hazards or unsafe practices that **COULD** result in minor personal injury or damage to equipment or property.*



A brief statement of fact, experience or importance that is given as an aid or explanation.



The hazardous area must be de-classified prior to removing a junction box cover or opening a detector assembly with power applied.



1. Be sure to read and understand the entire instruction manual before installing or operating the Eagle Quantum Premier® system. Only qualified personnel should install, maintain or operate the system.
2. The wiring procedures in this manual are intended to ensure proper functioning of the devices under normal conditions. However, because of the many variations in wiring codes and regulations, total compliance with these ordinances cannot be guaranteed. Be certain that all wiring and equipment installation meets or exceeds the latest revisions of the appropriate NFPA Standards, National Electrical Code (NEC), and all local ordinances. If in doubt, consult the Authority Having Jurisdiction (AHJ) before wiring the system.

All wiring shall be installed in accordance with the manufacturer's recommendations.
3. Some Eagle Quantum Premier devices contain semiconductor devices that are susceptible to damage by electrostatic discharge. An electrostatic charge can build up on the skin and discharge when an object is touched. Always observe the normal precautions for handling electrostatic sensitive devices, i.e. use of a wrist strap (if available) and proper grounding.
4. To prevent unwanted actuation, alarms and extinguishing devices must be secured prior to performing system tests.

Section 2 Introduction

SYSTEM DESCRIPTION

The Eagle Quantum Premier (EQP) system combines "fire detection and extinguishing agent release" and "hazardous gas monitoring" in one complete package. The system is intended for use in hazardous locations and is designed to meet the requirements of approval agencies from around the world.

The system consists of a Controller and a number of addressable microprocessor based field devices. The Controller coordinates system device configuration, monitoring, annunciation, and control, while the field devices communicate their status and alarm conditions to the Controller.

The EQP controller can be arranged in a redundant configuration, thereby increasing the availability of the system. The controllers work in "Master" and "Hot Standby" mode.

Various combinations of field devices can be configured as part of the system. The actual selection depends on the requirements of the application and the regulations that cover the type of protection required. See Figure 2-1 for a block diagram of the Eagle Quantum Premier system.

All field devices are tied into a communication loop that starts and ends at the Controller. Each device connected to the communication loop is assigned a unique identity by setting its address switches. All other device operation parameters are configured through Det-Tronics "Safety System Software". These selections define the type of device and how it is to operate. This system configuration data is then downloaded into the Controller.

A programmed Controller is configured to automatically download the configuration data into the individual devices when they first communicate with the Controller.

In addition to Det-Tronics advanced flame and gas detectors, Eagle Quantum Premier offers the capability of incorporating third party fire and gas protection equipment into the system. These can be either input or output devices. Typical input devices include manual fire alarm "call boxes", heat detectors, and

analog combustible or toxic gas measurement instruments. Typical output equipment includes solenoids, strobes, and horns. All equipment is monitored for wiring fault conditions.

For complete system integration, the Controller has the capability to communicate with other systems such as PLCs and DCSs. Different communication protocols are supported, allowing the Controller to communicate with other systems either directly or through communication gateways.

NOTE

For specific information relating to the SIL 2 rated EQP system, refer to manual number 95-8599.

COMMUNICATIONS LOOP

Eagle Quantum Premier utilizes a Det-Tronics Signaling Line Circuit (SLC), a version of Echelon's Local Operation Network (LON) customized specifically for Eagle Quantum Premier. This network provides several key advantages:

- ANSI/NFPA Class X performance of SLC
- Peer-to-peer communications
- Short message formats
- Expandability

The Controller utilizes several mechanisms to continuously check the LON loop for fault conditions, thereby providing the highest level of reliable communication.

Every device on the LON loop has the ability to communicate with the Controller at any time. This is typically referred to as distributed peer-to-peer communications. This design allows for immediate alarm messages to be sent from the field devices to the Controller.

All messages are kept short in order to maximize network performance. This minimizes network bottlenecks.

The Eagle Quantum Premier system is easily modified to accommodate design changes or plant expansions. This can involve adding LON sections, repositioning LON sections, or removing LON sections from the loop. There are LON communication implementation details that affect and limit how the LON loop is changed.

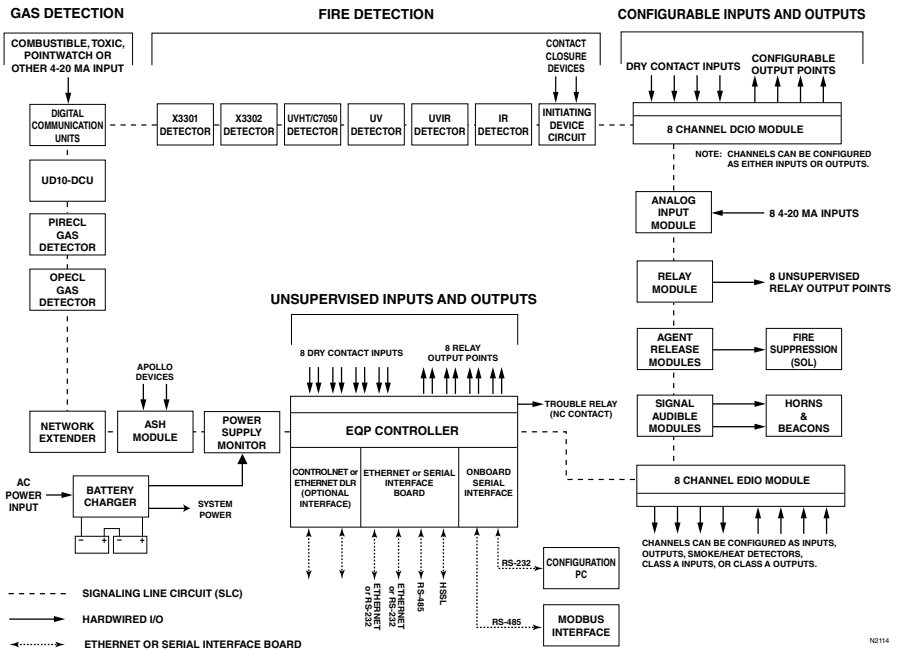

Figure 2-1—Block Diagram of Eagle Quantum Premier System

Only devices that have been approved for use with Eagle Quantum Premier can be connected up to the LON. All approved devices have been tested and certified to operate properly on the LON.

LON COMMUNICATION HEARTBEAT

The Controller continuously broadcasts a heartbeat signal over the LON loop. This heartbeat is used for verifying the integrity of the LON loop and for keeping the field devices from going into a fault isolation mode. Once every second, the heartbeat contains the current time and date, which are used by the field devices to log status events and calibrations.

The Controller continuously tests LON continuity by sending out a heartbeat on one LON port and then listening for it on the other LON port. The Controller also broadcasts the heartbeat signal in the opposite direction around the loop. This ensures that all field devices, the LON Network Extenders (NE), and communication wiring are correctly passing the digital information around the loop.

The field devices use the heartbeat as a mechanism to ensure that there is a communication path back to the Controller. If the field device does not receive a heartbeat for a period of time, the device will go into a LON fault isolation. In this situation, the device opens one side of the LON and listens for a heartbeat on the other side. If the device doesn't receive a heartbeat, it listens on the other side of the LON and opens the opposite LON connection.

Table 2-1—Controller Based Faults

Controller Faults Shown on Text Display	Trouble LED	LON Fault LED	Trouble Relay
Controller Fault	x		x
Device Offline	x		x
Extra LON Device	x		x
Invalid Config	x		x
Lon Fault	x	x	x
LON Ground Fault	x		x
Power Fail 1	x		x
Power Fail 2	x		x
RTC Fault	x		x
Redundancy Fault*	x		x

*Only for controller pair configured for redundancy.

Table 2-2—Field Device Based Faults

Field Device Faults Shown on Text Display	Trouble LED	Trouble Relay
290 Volt Fault	X	X
AC Failed	X	X
Battery Fault	X	X
Beam Block	X	X
Calibration Fault	X	X
Channel Open	X	X
Channel Short	X	X
Dirty Optics	X	X
Ground Fault Negative	X	X
Ground Fault Positive	X	X
IR Auto Oi Fault	X	X
IR Fault	X	X
IR Manual Oi Fault	X	X
Low Aux Power Fault	X	X
Missing IR Sensor Fault	X	X
Missing UV Sensor Fault	X	X
Power Supply Fault	X	X
Sensor Fault	X	X
Supply Voltage Fault	X	X
Tx Lamp Fault	X	X
UV Auto Oi Fault	X	X
UV Fault	X	X
UV Manual Oi Fault	X	X

THEORY OF OPERATION

During normal operation, the Controller continuously checks the system for fault conditions and executes user defined programmed logic that coordinates the control of the field devices. At the same time, the field devices are continuously monitoring for device based fault and alarm conditions.

When a fault condition occurs, the Controller displays the fault condition on the Vacuum Fluorescent Text Display, activates the appropriate fault LED(s), activates the Trouble signal using the Controller's internal enunciator, and de-energizes the Controller's Trouble relay.

Controller based fault conditions include the Controller status and LON communications such as the heartbeat being sent around the loop and the field device loss of communications. Controller based fault conditions are listed in Table 2-1.

Field device based fault conditions are transmitted to the Controller, where they are then annunciated. Refer to Table 2-2 for a listing of field device faults. Each field device transmits its status to the Controller on a regular basis.

When an alarm condition occurs, the Controller displays the alarm condition on the text display, activates the appropriate Alarm LED(s), and activates the alarm signal using the Controller's internal annunciator.

Table 2-3—Eagle Quantum Premier Status Update Rates

Controller Type	# of Devices	Output Only	Input – No Exception	Input – With Exception	Input – With Exception
		ARM SAM	IDC U-Series (UV & UVIR)	DCU DCIO, EDIO, AIM Relay Module ASH Module X-Series OPECL	PIRECL
EQ3001	1 to 100	1 Second	1 Second	1 Second	1 Second
	101 to 200	2 Seconds	2 Seconds	2 Seconds	1 Second
	201 to 246	5 Seconds	2 Seconds	3 Seconds	1 Second
EQ3150*	1 to 50	1 Second	1 Second	1 Second	1 Second
	51 to 100	2 Seconds	2 Seconds	2 Seconds	1 Second
	101 to 150	5 Seconds	2 Seconds	3 Seconds	1 Second
EQ3016	1 to 16	1 Second	1 Second	1 Second	1 Second

Each field device must communicate alarm and fault conditions to the Controller. The timing for transmitting alarms and faults to the Controller is displayed in Table 2-3.

NOTE

All fault and alarm conditions are latched on the Controller. To reset the Controller, conditions indicated on the text display must currently be in the OFF state. Pushing the reset button then initiates a Controller reset. Active alarms will remain through a Controller reset.

CONTROLLER LOGS

The controller has an internal alarm and event log. The logs can be accessed via the S³ software configuration ports (Configuration Port or Port 3) using a RS-232 serial cable and a Windows™ computer. The controller can save up to 4,095 alarms and events in the controller memory.

CONTROLLER USER LOGIC

The Controller continuously executes the user logic programs that are programmed using S³ software. The user logic programs are set up in the same fashion as IEC 61131-3 programmable logic programmed into Programmable Logic Controllers (PLCs). Block diagram logic gates are tied together

with inputs, outputs, and other logic gates to perform a specific task. A number of tasks can be tied together to perform a system function.

Typical programmed functions include flame/gas voting, timing delays, timing executions, latching conditions, alarm and trouble notification, suppression control, condition control, and process shutdown notification.

The Controller executes program logic by starting with the first logic page of the first program and then progressing onto subsequent pages of the same program. In turn, subsequent programs are then executed.

Every one hundred milliseconds, the Controller will start executing the user logic that is programmed into the Controller. Within this logic execution cycle, the Controller will execute as many of the logic pages as possible. If all programmed logic is executed in a cycle, the Controller will start executing program logic with the next cycle. Otherwise, subsequence logic execution cycles are used to finish executing the remaining logic gates. Only when all the logic gates have been executed will the Controller start over. The Controller will start executing the first logic page of the first program at the beginning of the next logic cycle.

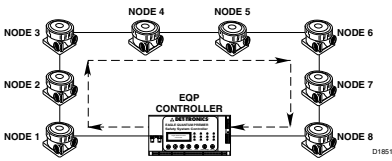

Figure 2-2—Normal Communication over the LON

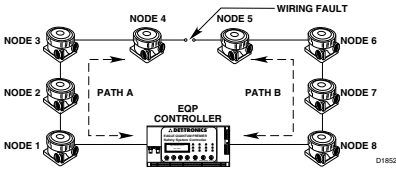

Figure 2-3—Communication over the LON with a Single Wiring Fault

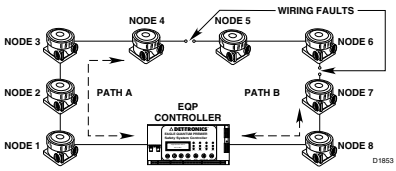

Figure 2-4—Communication over LON with Multiple Wiring Faults

The process is repeated until either a heartbeat is located or a LON fault timeout period of two hours is reached. The LON fault isolation routine is disabled and the LON fault isolation relays are closed when the LON fault timeout period has elapsed. The LON fault isolation routine will be enabled when the device again receives a heartbeat.

For a single wiring fault, the field devices with the fault will isolate the fault by opening LON fault isolation relays. After the field devices isolate the wiring fault, communications will be resumed between the Controller and field devices. Refer to Figure 2-3.

MULTIPLE WIRING FAULTS

In the event of multiple wiring faults on the LON, the devices between the faults will continue to function, but the faults will prevent them from communicating with the Controller. See Figure 2-4. In this example, nodes 1 to 4 communicate using one Controller port (path A) and nodes 7 and 8 use the other Controller port (path B). Nodes 5 and 6 are unable to report to the Controller because they are isolated by the two wiring faults. If a device is prevented from communicating with the Controller, the text display on the Controller will show the message "Device Offline".

COMMUNICATION NETWORK FAULT OPERATION

During normal operation, the Controller is continuously broadcasting a heartbeat around the communication loop as shown in Figure 2-2. The Controller broadcasts the heartbeat in both directions. At the same time, the field devices are transmitting status information to the Controller over the communication loop.

Every field device except the network extender has two LON fault isolation relays. Each relay is tied to a communication port on the device. When a field device fails to receive the heartbeat from the Controller, the device initiates a LON fault isolation routine. The isolation routine disconnects one of the communication ports via one of the LON fault isolation relays. The device listens for a heartbeat on the communication port that is connected. If a heartbeat is not found, the routine then disconnects the other communication port and listens for a heartbeat on the connected side.

IMPORTANT!

Since it is impossible to predict where a network fault might occur or exactly what effect it will have on actual system operation, it is important to diagnose and repair any fault as soon as possible after it is detected to ensure continuous, uninterrupted system operation.

MAJOR COMPONENT DESCRIPTIONS

The system has three (3) main component groups — the System Controller, LON (Local Operating Network), and Intelligent Field Devices.

SYSTEM CONTROLLER

The Controller (see Figure 2-5) performs all communication, command, and control functions for the system. The Controller supports both “Static” and “Programmable” logic. Other features include:

- Redundant controller capability
- User pushbutton controls (reset, acknowledge, etc.)
- “Real time” system clock
- Internal alarm sounder
- Vacuum fluorescent text based display that shows current system status
- 8 programmable unsupervised inputs
- 8 programmable unsupervised relay outputs
- RS-485 Modbus RTU communication interface that supports coils, discrete inputs, and holding registers
- Optional ControlNet communication board supports redundant communication channels.
- Optional Ethernet DLR communication board supports Ethernet Device Level Ring communications.
- Ethernet Interface Board supports configuration, MODBUS TCP/IP, controller redundancy, and RS-485 MODBUS.
- Serial Interface Board supports configuration, RS-232 MODBUS, controller redundancy, and RS-485 MODBUS.



Figure 2-5—System Controller

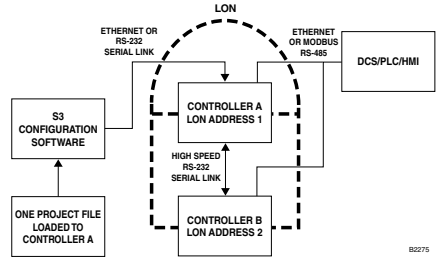

Figure 2-6—Block Diagram of EQP System with Redundant Controllers

Controller Redundancy

The EQP controllers can be configured as a redundant pair. See Figure 2-6. The redundancy scheme is a hot standby system that offers the following primary features:

- Automatic configuration of the standby controller
- Bumpless transfer
- Forced and automatic switchover
- No downtime on controller replacement
- Automatic synchronization between controllers
- Increased system availability

During normal operation one controller acts as the “Master” while the other acts as the “Hot Standby”.

Terminology used for redundancy:

Master controller This is the normal mode for non-redundant and master controllers. User logic is executed, outputs are being controlled and all serial and/or Ethernet ports are active.

Standby controller This controller is receiving all inputs but does not have any control over the outputs and user logic is not executed. The standby controller receives update information from the master controller to ensure a bumpless transfer should a controller switchover occur.

Table 2-4—Ports on Ethernet Interface Board

Port Name	Comm	Function
Serial Port 2	RS-485	ModBus (Master/ Slave) Ground Fault Monitored, Isolated
Ethernet Port 3	Ethernet	MODBUS TCP/IP (Master/Slave) S ³ Configuration
Ethernet Port 4	Ethernet	MODBUS TCP/IP (Master/Slave)
HSSL Redundancy Port	RS-232	Redundant Controller to Controller Only

Primary controller The controller assigned address 1.

Secondary controller The controller assigned address 2.

Bumpless transfer During a controller switchover no change in output will occur due to the switchover.

Ethernet Interface Board

The Ethernet Interface Board supports two additional serial ports and two Ethernet ports. See Table 2-4. Ethernet supports 10/100 Mbs communication. Figure 2-7 shows the Ethernet TCP/IP Server/Client and Modbus RTU Master/ Slave relationship. For a redundant controller configuration, the board is required in both controllers.

Table 2-6—Ports on ControlNet Interface Board

Port Name	Comm	Function
Port A	ControlNet	ControlNet Communication
Port B	ControlNet	ControlNet Communication

Table 2-5—Ports on Serial Interface Board

Port Name	Comm	Function
Serial Port 2	RS-485	ModBus (Master/ Slave) Ground Fault Monitored, Isolated
Serial Port 3	RS-232	ModBus (Master/ Slave) S ³ Configuration
Serial Port 4	RS-232	ModBus (Master/ Slave)
HSSL Redundancy Port	RS-232	Redundant Controller to Controller Only

Serial Interface Board

The Serial Interface Board supports up to four additional serial ports. See Table 2-5. For a redundant controller configuration, the board is required in both controllers.

ControlNet Board or Ethernet DLR Board (Optional)

An optional ControlNet Board or Ethernet Device Level Ring (DLR) Board can be installed to allow ControlNet or Ethernet DLR communication to a compatible PLC. Both interfaces operate in a non-interfering manner. The functionality of the ControlNet and Ethernet DLR boards is not covered by any approval. Both options offer two ports. See Tables 2-6 and Table 2-7. The interfaces must be configured through S³ prior to use. Consult the factory for details. For redundant controller configurations, identical option boards are required in both controllers.

Table 2-7—Ports on Ethernet DLR Interface Board

Port Name	Comm	Function
Port 1	Ethernet DLR	Ethernet DLR Communication
Port 2	Ethernet DLR	Ethernet DLR Communication

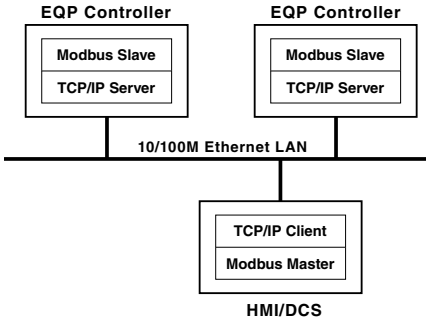

Figure 2-7—Ethernet TCP/IP Server/Client Relationship & Modbus RTU Master/Slave Relationship

Controller-to-Controller Communication (SLC485)

The EQP controllers can be configured to communicate with up to 12 controllers via RS-485 communication. The controller-to-controller scheme provides the ability to meet NFPA 72 SLC requirements with the following primary features:

- Modular trouble and alarm configuration
- Multiple zone application with controller-to-controller communication
- Multiple media options.

EQP Supervising System (EQPSS)

The Det-Tronics EQP controllers can be supervised via the EQPSS using PCs and HMI. Each EQPSS PC can communicate with up to 12 EQP controllers over Ethernet. This is a Det-Tronics solution. Please consult the factory for more information.

EQP Marine Application System

For information regarding EQP Marine Application Systems, refer to Appendix D.

LOCAL OPERATING NETWORK (LON)

The LON is a fault tolerant, two wire, digital communication network. The circuit is arranged in a loop starting and ending at the Controller. The circuit supports up to 246 intelligent field devices spread over a distance of up to 10,000 meters (32,500 feet).



Figure 2-8—Eagle Quantum Premier Network Extender

NOTE

All LON devices support ANSI/NFPA 72 Class X communication with the Controller.

Network Extenders

Transmitted signals can travel a maximum distance of 2,000 meters through LON communication wire. At the end of this distance, a network extender (see Figure 2-8) must be installed to rebroadcast the communications into the next wire segment. For every network extender added, the length of the communications loop extends up to 2,000 meters. Due to propagation delays around the loop, the maximum loop length is limited to 10,000 meters.

NOTES

A network extender is required for communication loops greater than 60 nodes.

Communication wire segment lengths are dependant upon physical and electrical characteristics of the cable. Refer to the installation section for LON cable wire information.

No more than six network extenders may be used on the communication loop.

When a network extender is installed in the communication loop, up to 40 field devices can be installed per network segment. The network segment is the wiring segment between two network extenders or between a network extender and a controller.



Figure 2-9—Ground Fault Monitor

EQ21xxPS Series Power Supplies and EQ2100PSM Power Supply Monitor

The Power Supply, Power Supply Monitor, and backup batteries are used to provide power to the system. The power supply monitor communicates trouble conditions to the Controller. Monitored status conditions include: power supply failure, loss of AC power, loss of battery power, power ground fault, AC and DC voltage (hi/low level), and backup battery current charge levels.

The Power Supply provides main and backup power to the EQP System. The device includes many features such as voltage regulation, high efficiency, and high power factor.

An equalize switch is located on the front panel of the charger for manual activation, or a multi-mode electronic timer can be used for automatic activation. Steady state output voltage remains within $\pm 1/2\%$ of the setting from no load to full load for AC input voltages within $\pm 10\%$ of the nominal input voltage.

EQP21XXPS(-X) Power Supplies and EQP2410PS(-P) Converter

The Power Supplies and Converter provide main and backup power to the EQP System in ordinary and marine applications. Refer to Section 3 of this manual for complete information.

Detector	Manual Number
X3301	95-8527
X3301A	95-8527 & 95-8534
X3302	95-8576
X5200	95-8546
X2200	95-8549
X9800	95-8554
UVHT	95-8570

EQ2220GFM Ground Fault Monitor

The EQ2220GFM Ground Fault Monitor (see Figure 2-9) provides ground fault monitoring in a system that includes a floating 24 Vdc power source. The device detects ground fault conditions on \pm power and all secondary I/O circuits. A positive or negative ground fault condition is indicated immediately by local LEDs, and by a relay contact after a 10 second time delay. The ground fault monitor is intended to be mounted in the same enclosure as the controller.

FIELD DEVICES

Flame Detectors

For flame detector installation, operation, maintenance, specifications and ordering information, refer to Table 2-8.

For information regarding USCG Approval of the X3301 Flame Detector, refer to Appendix D.

NOTE

Existing Eagle Quantum field devices such as EQ22xxUV and EQ22xxUVIR are supported by the Eagle Quantum Premier system (not FM Approved).

EQ3730EDIO Enhanced Discrete Input/Output Module

The 8 Channel EDIO Module (see Figure 2-10) expands the Input and Output capability of the Eagle Quantum Premier System.

The unit is designed to provide continuous and automated fire/gas protection, while ensuring system operation through continuous supervision of System Inputs/Outputs.

The EDIO module provides eight channels of configurable input or output points that can be programmed for supervised or unsupervised operation. Each input point can accept fire detection devices such as heat, smoke, or unitized flame detectors. Each output point can be configured for signaling or releasing output operation. Each channel on the module is provided with individual indicators for active and fault conditions.

IMPORTANT

For Class A wiring, two input/output channels are combined, thereby supporting up to four input/output circuits.

NOTE

An input must be active for at least 750 milliseconds in order to be recognized.

The EDIO module can be mounted directly to a panel, or it can be DIN rail mounted. System status can be determined using the troubleshooting procedures, Eagle Quantum Safety System Software (S³) and the status indicators on the module.

Refer to the Enhanced Discrete Input/Output Module Specification Data sheet (form number 90-1189) for additional information.



Figure 2-10—Enhanced Discrete Input/Output Module

EQ3700 8 Channel DCIO Module

The 8 Channel Discrete Input/Output (DCIO) Module (see Figure 2-11) consists of eight individually configured channels. Each channel is configured as either an input or output with the appropriate wiring supervision. Wiring supervision includes none, open circuits, and "open and short" circuits. In addition to defining the type of supervision, an input channel is also configured to generate the appropriate static logic alarm message to the controller.

NOTE

NFPA 72 requires wire supervision selection for fire detection and notification devices (IDC, NAC, supervisory and releasing devices).

Heat, smoke, or unitized flame detectors can be wired into channels defined as inputs. Horns, strobes/beacons, and solenoids can be wired into channels defined as outputs.

NOTE

The DCIO outputs only support equipment that operates on 24 vdc (not to exceed 2 amperes per channel).

The DCIO has two device status LEDs, as well as two LEDs for each channel. On the device level, one green LED indicates power, while the other amber LED indicates a LON CPU fault. For each channel, one red LED indicates channel activation and the other amber LED indicates a fault condition when wiring supervision is defined for the channel.

Refer to the DCIO Specification Data sheet (form number 90-1149) for additional information.



Figure 2-11—DCIO Module

EQ3720 8 Channel Relay Module

The 8 Channel Relay Module (see Figure 2-12) consists of eight individually configured output channels.

NOTE

The relay module only supports equipment that operates on 24 vdc (not to exceed 2 amperes) at each output channel.

The relay module has two LEDs for the device and two LEDs for each channel. On the device level, one green LED indicates power, while the other amber LED indicates a LON CPU fault. For each channel, one red LED indicates channel activation and the other amber LED indicates that the module operating voltage is low or that the module has not been configured (all eight channel LEDs blink).

Refer to the Relay Module Specification Data sheet (form number 90-1181) for additional information.



Figure 2-12—Eight Channel Relay Module

EQ3710AIM Analog Input Module

The 8 Channel Analog Input Module (see Figure 2-13) provides a means of connecting devices with a calibrated 4-20 mA output signal to the Eagle Quantum Premier System.

The Analog Input Module (AIM) provides 8 configurable channels that can be set for either combustible gas mode or universal mode. The combustible gas mode provides a number of automatically programmed settings, and alarm thresholds that are limited to approval body requirements. The universal mode is used for generic devices where control over all configuration parameters is required. All devices must provide their own calibration facilities.

For fire detector 4-20 mA inputs, the Analog Input Module (AIM) is certified for use as an NFPA 72 Class B Approved input.

Refer to the Analog Input Module Specification Data sheet (form number 90-1183) for additional information.



Figure 2-13—Eight Channel Analog Input Module

EQ3750ASH Addressable Smoke & Heat Module

The Addressable Smoke and Heat (ASH) Module (see Figure 2-14) is an interface device designed to provide continuous and automated fire protection for the EQP system.

The ASH module is located directly on the LON of the EQP system, with a loop of up to 64 addressable devices tied into the ASH module. This allows all of the flame, gas, and addressable smoke and heat detectors to run on one system, enabling the EQP controller to announce a fire alarm from either its own LON based I/O, or from the connected addressable smoke and heat detection loops. The EQP controller can support up to 10 ASH modules.

The ASH module can support a variety of Apollo Discovery and XP95 devices, including smoke, heat, manual call, sounders, beacons and I/O modules. The addressable devices are configured individually via the S³ software.

To ensure reliable system operation, the ASH module continuously monitors its input and output circuits for opens and short circuit conditions.

During normal operation, the ASH module continuously checks the loop for fault conditions and executes user defined programmed logic that coordinates the control of the field devices. The ASH module reports any device based fault and alarm conditions to the EQP controller.

The EQP Controller continuously monitors the status of the ASH module, as well as the status of each device connected to the ASH module. ASH module alarm and fault status conditions are logged in the EQP controller.

System status can be determined using S³ software or the status indicators on the ASH module, where LEDs announce power on, faults, or an active device on the loop.

Refer to the ASH module instruction manual (form number 95-8654) for additional information.



Figure 2-14—Addressable Smoke & Heat Module

EQ25xxARM Agent Release Module

The EQ25xxARM Series Agent Release Module (ARM) (see Figure 2-15) provides agent release or deluge pre-action capability. The device is controlled by programmable logic in the Controller. Time delay, abort and manual release sequences allow the device output to be programmed for use in unique applications.

The device is field programmed to operate in one of the following modes:

- Timed— Output is activated for a field selectable duration from 1 to 65,000 seconds.
- Continuous— Output latches until reset.
- Non-latching— Output follows the input.



Figure 2-15—Agent Release Module

The device can monitor and control two output devices (24 vdc rated) that are programmed and energized together. The release circuits are compatible with a variety of solenoid or initiator based suppression systems.

The release circuit is supervised for open circuit conditions. If a trouble condition occurs (open circuit or solenoid supply voltage less than 19 volts), it will be indicated at the Controller. Each output is rated at 2 amperes and auxiliary input terminals are provided for additional 24 vdc output power where needed.

NOTE

For deluge and pre-action applications, the input voltage to the ARM or DCIO must be 21 VDC minimum with connection to any solenoid listed in Table 2-9 or 2-10. Wiring must be in accordance with the listed maximum wiring lengths.

Refer to the EQ25xxARM Specification Data sheet (form number 90-1128) for additional information

Table 2-9—Solenoid Compatibility with Agent Release Module for Deluge and Pre-Action Applications

FM Group	Device
B	ASCO T8210A107
D	ASCO 8210G207
E	Skinner 73218BN4UNLVNOC111C2
F	Skinner 73212BN4TNLVNOC322C2
G	Skinner 71395SN2ENJ1NOH111C2
H	Viking 11601

Table 2-10—Maximum Wiring Length for FM Approved Solenoids for Deluge and Pre-Action Applications

Solenoids			Maximum Wire Length in Feet (Meters)			
FM Solenoid Group	Manufacturer	Model	12 AWG	14 AWG	16 AWG	18 AWG
B	ASCO	T8210A107	183 (56)	115 (35)	72 (22)	46 (14)
D	ASCO	8210G207	314 (96)	198 (60)	124 (38)	78 (24)
E	Skinner	73218BN4UNLVNOC111C2	331(101)	208 (63)	131 (40)	82 (25)
F	Skinner	73212BN4TNLVNOC322C2	130 (40)	82 (25)	51 (16)	32 (10)
G	Skinner	71395SN2ENJ1NOH111C2	331 (101)	208 (63)	131 (40)	82 (25)
H	Viking	11601	180 (55)	110 (34)	70 (21)	45 (14)

EQ25xxSAM Signal Audible Module

The EQ25xxSAM Series Signal Audible Module (SAM) (see Figure 2-16) provides two indicating circuits for controlling UL Listed 24 vdc polarized audible/visual indicating appliances.

The device is located on the LON and is controlled by programmable logic in the Controller.

Each output circuit is independently programmable to allow notification of separate events. Each output can be individually activated for any one of the following pre-defined outputs:

1. Continuous
2. 60 beats per minute
3. 120 beats per minute
4. Temporal pattern.

Device outputs operate in the reverse polarity manner when activated. Each output is rated at 2 amperes. Auxiliary power input terminals are provided for additional 24 vdc signaling power where required. The output circuits are supervised for open and short circuit conditions. If a wiring fault occurs, a trouble condition will be indicated at the Controller.

Refer to the EQ25xxSAM Specification Data sheet (form number 90-1129) for additional information



Figure 2-16—Signal Audible Module

EQ22xxIDC Series Initiating Device Circuit (IDC)

There are three IDC models available (see Figure 2-17):

The **EQ22xxIDC** allows discrete inputs from smoke/heat detectors, manual call stations or other contact devices.

The IDC accepts two dry contact inputs for use with devices such as relays, pushbuttons, key switches, etc. The IDC supports ANSI/NFPA 72 Class B supervised input circuits

Each circuit requires its own end of line (EOL) resistor for monitoring circuit continuity. Nominal resistance of the resistor is 10 k ohms.

The **EQ22xxIDCGF** Initiating Device Circuit Ground Fault Monitor (IDCGF) responds to the presence of a ground fault within the power circuitry of the system. It provides an unsupervised dry contact input and ground fault monitoring circuitry for indicating a power supply trouble condition. It is intended for use with a third party power supply.

The **EQ22xxIDCSC** Initiating Device Circuit Short Circuit (IDCSC) is similar to the IDC, but supports supervision per EN 54 for European installations.

Refer to the EQ22xxIDC Specification Data sheet (form number 90-1121) for additional information.

NOTE

Input types (e.g. fire alarm, trouble, and gas alarms) are configurable through Det-Tronics Safety System Software (S³).



Figure 2-17—Initiating Device Circuit

EQ22xxDCU and EQ22xxDCUEX Digital Communication Units

The EQ22xxDCU Digital Communication Unit (DCU) is an analog signal input device that accepts a 4 to 20 milliampere signal. The device is typically connected to gas detectors, where the analog signal represents the gas concentration.

Calibration of the DCU involves a non-intrusive procedure that can be performed by one person at the device without declassifying the area.

The device supports two alarm setpoints that are defined as part of the device's configuration setup. When detecting combustible gases, the alarm setpoints represent low and high gas alarm levels. When detecting oxygen, the alarms represent the range for the acceptable oxygen level. If oxygen drops below the alarm range, a low alarm is generated by the device.

PointWatch/DuctWatch IR gas detector as well as electrochemical sensors (hydrogen sulfide, carbon monoxide, chlorine, sulfur dioxide, and nitrogen dioxide) are examples of devices that can be connected to the DCU.

NOTE

A catalytic sensor can be connected to a DCU through a transmitter, which converts the millivolt signal to a 4 to 20 milliampere signal.

The EQ22xxDCUEX is a specialized version of the DCU that contains a transmitter for connection to a Det-Tronics Model CGS catalytic combustible gas sensor.

Refer to the EQ22xxDCU Specification Data sheet (form number 90-1118) for additional information.

PIRECL PointWatch Eclipse

The Pointwatch Eclipse® Model PIRECL is a diffusion-based, point-type infrared gas detector that provides continuous monitoring of combustible hydrocarbon gas concentrations in the range of 0 to 100% LFL.

The LON supervision meets Signaling Line Circuit (Class X) requirements per NFPA72: 2010 for the Model PIRECL.

For PIRECL installation, operation, maintenance, specifications and ordering information, refer to form number 95-8526.

NOTE

The low alarm range for the EQP PIRECL is 5-40% LFL (the standard PIRECL is 5-60% LFL).

For information regarding USCG Approval of the PIRECL Detector, refer to Appendix D.

OPECL Open Path Eclipse

The Open Path Eclipse™ Model OPECL is an open path infrared gas detection system that provides continuous monitoring of combustible hydrocarbon gas concentrations in the range of 0 to 5 LFL-meters, over a distance of 5 to 120 meters.

The LON supervision meets Signaling Line Circuit (Class X) requirements per NFPA72: 2010 for the Model OPECL.

For OPECL installation, operation, maintenance, specifications and ordering information, refer to form number 95-8556.

UD10 DCU Emulator

The FlexVu® Model UD10 DCU Emulator (UD10-DCU) is designed for applications that require a gas detector with digital readout of detected gas levels. Its LON interface board makes the UD10-DCU compatible with Eagle Quantum Premier systems by digitizing the 4-20 mA analog signal from the attached sensor/transmitter and transmitting the value as a process variable over the LON to the EQP controller. The UD10-DCU is designed for use with most currently available Det-Tronics gas detectors.

For a list of compatible gas detectors, as well as information regarding installation, operation, maintenance, specifications and ordering information, refer to form number 95-8656.

Section 3 Installation

NOTE

For specific information regarding systems meeting EN54 standards, refer to the EQ5400 Series operation manual 95-8642.

SAFETY SYSTEM DESIGN REQUIREMENTS

Many factors need to be considered when determining proper EQP System design. The following paragraphs will discuss these factors and other issues useful in designing, installing and configuring the Eagle Quantum Premier System.

IDENTIFYING THE AREA OF PROTECTION

In order for the system to provide optimum coverage and protection, it is critical to properly define the required "Area of Protection" (total area being monitored by the system). The area of protection should include all hazard sources requiring monitoring, as well as suitable locations for mounting detection, extinguishing, notification, and manual devices. In order to accurately define the area of protection and provide maximum protection, all potential "Real" and "False" hazard sources must be identified. The number and location of Real Hazards determines the extent of the area of protection, and impacts all subsequent design decisions.



When drilling through surfaces in the process of mounting equipment, verify that the location is free of electrical wiring and electrical components.

IDENTIFYING WIRING, NETWORK (LON), AND SYSTEM POWER REQUIREMENTS

General Wiring Requirements



DO NOT open any junction box or device enclosure when power is applied without first de-classifying the hazardous area.



Any deviation from the manufacturer's recommended wiring practices can compromise system operation and effectiveness. ALWAYS consult the factory if different wire types or methods are being considered.

NOTE

All field wiring must be marked per NFPA 70 Article 760.

NOTE

Specific installation requirements may differ depending on local installation practices and compliance with third party certifications. For local installation practices, consult the local authority having jurisdiction. For compliance with third party certifications, consult the appropriate appendix in this manual for additional installation requirements.

Power Wiring



For deluge and pre-action applications, input voltage to the DCIO or ARM must be 21 vdc minimum to ensure proper operation of the connected output device.



To ensure proper operation of field devices, the voltage input to the device (measured at the device) must be within the range indicated for that device in the "Specifications" section of this manual (18 Vdc minimum).

System Wiring (ATEX and IECEx)

For the interconnection of the modules within the EQP system, use fixed installed wiring. (For correct wiring size and type for a specific device, refer to the appropriate section in this manual.)

For ambient temperatures below -10°C and above $+60^{\circ}\text{C}$, use field wiring suitable for both minimum and maximum ambient temperatures.

The EQP Ex n modules may only be installed, connected or removed when the area is known to be non-hazardous. The screw terminals are to be tightened with a minimum torque of 0.5 Nm. Equipotential bonding connection facilities on the outside of electrical equipment shall provide effective connection of a conductor with a cross-sectional area of at least 4 mm².

The Eagle Quantum Premier system utilizes a power supply that provides an isolated 24 vdc battery backed-up power to the fire protection devices as described in NFPA 72. More than one power supply may be used in a system to provide power to different sets of equipment as part of the system.

The power supply wiring may consist of one or more daisy-chained wire segments providing power to the devices. For each of the daisy-chained wire segments, the installer must calculate the voltage drops that occur across the devices in order to determine the gauge of the wire that will be installed.

A power supply wiring diagram should contain information describing wire distances and current draws associated with all devices

connected to the wire segment. A typical power supply wiring recommendation is that the voltage drop from the power source to the end device should not exceed ten percent. Using 24 vdc as a reference, the maximum voltage drop should not exceed 2.4 vdc. A wire gauge must be selected to ensure that the end device has at least 21.6 vdc or higher.

In order to calculate the power supply voltage for the end device, calculate the voltage drops that occur due to each wire segment between the devices. This involves determining the total current draw and the two conductor wire resistance per each wire segment.

Example: Can 18 AWG wire be used to power three devices from the 24 vdc power supply? Refer to the figure below for wiring and device current draw information along with voltage drop calculations.

Answer: If the Authority Having Jurisdiction (AHJ) requires a voltage loss of 10% or less, only 16 AWG wire could be used, since the end device would require 21.4 vdc. If there is no local requirement, then 18 AWG wire could be used to provide power to the devices.

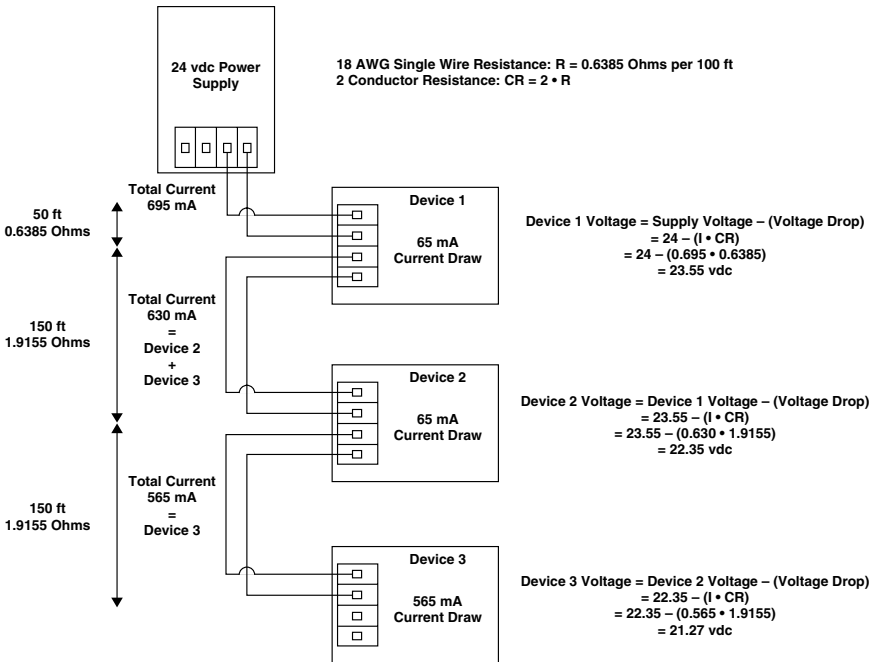

Determining Power Requirements

Tables 3-1 and 3-2 are provided for calculating the total current requirements for those parts of the system requiring battery backup.

Table 3-1—Standby Current Requirements at 24 vdc

Device Type	Number of Devices		Standby Current		Total Current for Device Type
EQP Controller		X	0.360	=	
EQ3LTM Module		X	0.001	=	
EDIO Module		X	0.075	=	
DCIO Module		X	0.075	=	
Power Supply. Monitor		X	0.060	=	
IDC/IDCGF/IDCSC		X	0.055	=	
X3301/X3301A - w/o heater		X	0.160	=	
X3301/X3301A - with heater		X	0.565	=	
X3302 - without heater		X	0.160	=	
X3302 - with heater		X	0.565	=	
X2200		X	0.135	=	
X9800 - without heater		X	0.085	=	
X9800 - with heater		X	0.420	=	
X5200 - without heater		X	0.155	=	
X5200 - with heater		X	0.490	=	
DCUJEX		X	0.145	=	
DCU with EC Sensor		X	0.060	=	
DCU with PointWatch		X	0.300	=	
DCU with DuctWatch		X	0.300	=	
Relay Module		X	0.120	=	
Analog Input Module		X	0.160	=	
EQ2220GFM		X	0.018	=	
PIRECL		X	0.270	=	
OPECL Transmitter		X	0.220	=	
OPECL Receiver		X	0.220	=	
ARM		X	0.075	=	
SAM		X	0.060	=	
Network Extender		X	0.090	=	
ASH Module		X	0.560	=	
EQ21xxPS Power Supply		X	0.350	=	
Other		X		=	
Total Standby Current for System (in amperes)				=	

Note: Standby current is the average current draw for the device in normal mode.
This table is for battery calculations only.

Table 3-2—Alarm Current Requirements at 24 Vdc

Device Type	Number of Devices		Alarm Current		Total Current for Device Type
EQP Controller		X	0.430	=	
EQ3LTM Module		X	0.001	=	
EDIO 8 Inputs		X	0.130	=	
EDIO 8 Outputs		X	0.075	=	
DCIO 8 Inputs		X	0.130	=	
DCIO 8 Outputs		X	0.075	=	
Relay Module		X	0.120	=	
Power Supply Monitor		X	0.060	=	
IDC/IDCGF/IDCSC		X	0.090	=	
X3301/X3301A - w/o heater		X	0.160	=	
X3301/X3301A - with heater		X	0.565	=	
X3302 - without heater		X	0.160	=	
X3302 - with heater		X	0.565	=	
X2200		X	0.135	=	
X9800 - without heater		X	0.085	=	
X9800 - with heater		X	0.420	=	
X5200 - without heater		X	0.155	=	
X5200 - with heater		X	0.490	=	
DCUEX		X	0.160	=	
DCU with EC Sensor		X	0.075	=	
DCU with PointWatch		X	0.320	=	
DCU with DuctWatch		X	0.320	=	
Analog Input Module		X	0.300	=	
EQ2220GFM		X	0.018	=	
PIRECL		X	0.275	=	
OPECL Transmitter		X	0.220	=	
OPECL Receiver		X	0.220	=	
ARM		X	0.120	=	
SAM		X	0.120	=	
Network Extender		X	0.090	=	
ASH Module		X	0.560	=	
EQ21xxPS Power Supply		X	0.350	=	
Other		X		=	
Total Solenoid Load				+	
Total Signaling Load				+	
Total Alarm Current for System (in amperes)				=	

Note: This table is for battery calculations only.

Table 3-3A—EQ21xxPS Power Supply Specifications

Characteristic	Power Supply		
	EQ2110PS/EQ2111PS	EQ2130PS/EQ2131PS	EQ2175PS/EQ2176PS
Input Voltage	120 vac	120/208/240 vac	120/208/240 vac
Input Current	4 Amps	11/6/6 Amps	24/15/12 Amps
Input Frequency	60 Hz – EQ2110PS	60 Hz – EQ2130PS	60 Hz – EQ2175PS
Input Frequency	50 Hz – EQ2111PS	50 Hz – EQ2131PS	50 Hz – EQ2176PS
Supply Rating	10 Amps	30 Amps	75 Amps
Maximum Alarm Current	10 Amps	30 Amps	75 Amps
Maximum Standby Current	3.33 Amps	10 Amps	25 Amps
Recharge Current	6.67 Amps	20 Amps	50 Amps
Minimum Battery Capacity**	40 AmpHours	120 AmpHours	300 AmpHours
Maximum Battery Capacity	100 AmpHours	300 AmpHours	750 AmpHours
Maximum Deluge Standby Current*	1 Amp	3 Amps	7.5 Amps

*Only applies to 90 hour back-up applications.

**Use a battery with a maximum charge rate that exceeds 25% of the rating of the power supply.

EQ211xPS, EQ213xPS and EQ217xPS Power Supplies

Refer to Table 3-3A for Power Supply ratings.

expected, either consider a heavier wire gauge or specify batteries with higher amp-hour ratings.

Backup Battery

Refer to Table 3-4 or 3-5 to calculate the minimum size of the backup battery (in amp hours). Select a sealed lead-acid battery with an adequate amp hour rating.

NOTE

Connect two batteries in series for 24 volts. Batteries must be protected from physical damage. The battery installation shall be adequately ventilated.

Battery Charger

Use the following formula to calculate the minimum battery charger size:

$$\text{Minimum Charge Rate} = \frac{\text{Alarm Current}}{48} + \frac{\text{Total Amp Hours}}{48}$$



CAUTION!

Care should be taken when considering the final voltage at the device during AC power loss. With loss of AC power, the device voltage will drop over time as the batteries lose their charge. If extended periods of AC power loss are to be

EQP21X0PS(-X) Power Supplies

The EQP2110PS(-P) and EQP2120PS(-B) Power Supplies are used in pairs where the primary source of input supply is connected to one and the secondary source is connected to the other. Each power supply may be backed up by another power supply of the same model or by a DC-DC converter (see Figures 3-23A, B and C for available configurations). A maximum of eight power supplies operated in parallel can be connected to each input supply. Both the primary and secondary sets must be individually capable of operating the system without the other supply. The secondary source is required to be continuously powered.

The use of these supplies is based upon acceptance of the local AHJ of the secure supply system that provides the secondary supply. These supplies must be used in a redundant configuration, where one bank of supplies is fed from the primary source and the other bank from the secondary source. Both primary and secondary supplies shall be continuously available and both rated for a minimum 100% of load.

Refer to Table 3-3B for power supply ratings.

Table 3-4—Backup Battery Requirements for Automatic Release of Extinguishing Systems Except Deluge

Standby Current _____	X	Standby Time* 24 Hours	=	Standby Amp Hours _____
Alarm Current _____	X	5 Minute Alarm Time* 0.083 Hours	=	Alarm Amp Hours _____
Sum of Standby and Alarm Amp Hours				=
Multiply by 1.2 (20% Safety Factor)				X

T0014B

Total Battery Amp Hour Requirement

* FM MINIMUM REQUIREMENT FOR EXTINGUISHING SYSTEMS IS 24 HOURS STANDBY TIME AND 5 MINUTES ALARM TIME.

Table 3-5—Backup Battery Requirements for Deluge and Pre-Action Applications

Standby Current _____	X	Standby Time* 90 Hours	=	Standby Amp Hours _____
Alarm Current _____	X	10 Minute Alarm Time* 0.166 Hours	=	Alarm Amp Hours _____
Sum of Standby and Alarm Amp Hours				=
Multiply by 1.2 (20% Safety Factor)				X

T0040B

Total Battery Amp Hour Requirement

* FM MINIMUM REQUIREMENT FOR DELUGE SYSTEMS IS 90 HOURS STANDBY TIME AND 10 MINUTES ALARM TIME.



IMPORTANT

The EQP21X0PS(-X) Power Supplies provide EQP System devices with power from input supply 120 to 220 V ac. Use of this power supply does not provide the source of the secondary supply such as secondary source batteries, their supervision or charging, or UPS. Per NFPA 72-2010 requirements, such power supply related requirements must be separately provided for and be accepted by the local Authority Having Jurisdiction (AHJ).

EQP2410PS(-P) Converter

The EQP2410PS(-P) Converter converts the DC input voltage to an adjustable, controlled and galvanically separated 24 Vdc output voltage. The converter is always connected to the secondary source.

Determining Power Requirements

Use of the EQP2110PS(-P) and EQP2120PS(-B) Power Supplies provides the primary and secondary supplies.

The EQP2410PS(-P) Converter provides the secondary supply only. It is used in conjunction with the EQP2110PS(-P) or EQP2120PS(-B) Power Supplies, which serve as the primary supply (see Figures 3-23A, B and C for available configurations). The customer is responsible for providing adequate secondary power supply source needs. The ac input current requirements for EQP2XX0PS(-X) in relation to EQP system dc current load (power supply output) are calculated using the following formula:

$$\text{Input Current} = [\text{Output Current} \times \text{Output Voltage} \div \text{Input Voltage} \div \text{Efficiency}] + 0.43 \text{ A}$$

Example:

$$[20 \text{ Adc} \times 28 \text{ Vdc} \div 120 \text{ Vac} \div 0.91] + 0.43 = 5.56 \text{ Aac}$$

For Standby Current (amperes ac) requirements, use Total Standby Current (amperes dc) for the system's applicable field devices from Table 3-1.

For Alarm Current (amperes ac) requirements,

Table 3-3B – EQP2XX0PS Power Supply and Converter Specifications

Characteristic	Device		
	EQP2110PS(-P) Power Supply	EQP2120PS(-B) Power Supply	EQP2410PS(-P) Converter
Input Frequency	60/50	60/50	N/A
Input Voltage	120/220 Vac	120/220 Vac	24 Vdc
Input Current, Max.	3.2 / 1.7 Iac	6.6 / 3.6 Iac	15.7 Idc
Output Voltage Range	24.5 ... 28.0 Vdc	24.5 ... 28.0 Vdc	24.5 ... 28.0 Vdc
Supply Rating	10	20	10
Maximum Alarm Current	10	20	10
Maximum Standby Current	10	20	10
Efficiency	88%	91% for 120 Vac 93% for 220 Vac	88%

use Total Alarm current (amperes dc) for the system's applicable field devices from Table 3-2.

NOTE

The suffix (-P) or (-B) defines the method for mounting the panel mount models:

(-P) = mounting plate

(-B) = mounting brackets.

Shield Grounding

Two shield ground terminals are provided inside the junction box of each device, and also at the System Controller. Connect shield ends to the terminals provided (not to each other) inside the junction box.



CAUTION!

Insulate the shields to prevent shorting to the device housing or to any other conductor. Refer to Appendix E for EMC Directive requirements.

Junction Box Grounding

All junction boxes must be electrically connected to earth ground.

Response Time vs. System Size

When designing a system, it is important to realize that by increasing the number of nodes (devices) on the communication loop, the amount of time required for a status change message from a detection device to reach the System Controller also increases.

The System Controller requires a specific length of time to process each bit of information that is transferred along the communication loop. As the number of nodes increases, so does the amount of data being processed as well as the time required for processing by the Controller.

If the fastest possible communication response time is an important criteria for a large system, it is recommended that the number of nodes on an individual loop be kept as small as possible. Consider using multiple controllers with fewer nodes per loop.

Moisture Damage Protection

Moisture can adversely affect the performance of electronic devices. It is important to take proper precautions during system installation to ensure that moisture will not come in contact with electrical connections or components.

In applications where the network wiring is installed in conduit, the use of watertight conduit seals, drains, breathers, or equivalent is recommended to prevent damage caused by condensation within the conduit.

Electrostatic Discharge

An electrostatic charge can build up on the skin and discharge when an object is touched. ALWAYS use caution when handling devices, taking care not to touch the terminals or electronic components.

CAUTION!

ALWAYS discharge static charges from hands before handling electronic devices or touching device terminals. Many devices contain semiconductors that are susceptible to damage by electrostatic discharge.

NOTE

For more information on proper handling, refer to Det-Tronics Service Memo form 75-1005.

GROUND FAULT MONITOR (GFM) INSTALLATION

Mounting

The GFM is a DIN rail mountable device designed to be mounted in the same enclosure as the EQP controller.

Wiring

1. Connect power wiring from the EQP controller power terminals 1 and 2 to the GFM terminals 1 and 2.
2. Connect power wiring from the GFM terminals 3 and 4 to the EQP controller power terminals 3 and 4.
3. Connect earth ground to terminal 5 or 10.
4. Connect the relay contacts as required.

Refer to Figure 3-1 for terminal block identification.

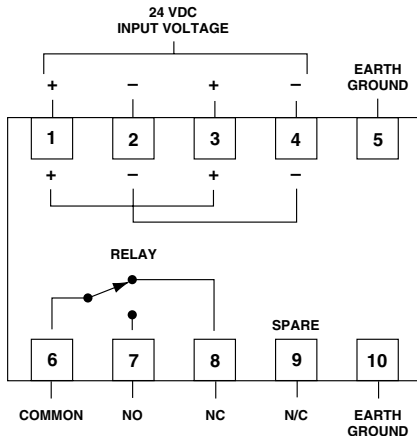

NOTE: RELAY CONTACTS ARE SHOWN IN THE REST STATE, NO POWER APPLIED. RELAY IS ENERGIZED WITH POWER APPLIED AND NO GROUND FAULT (TERMINALS 6 & 7 CLOSE, TERMINALS 6 & 8 OPEN).

Figure 3-1—Terminal Configuration for Ground Fault Monitor

NETWORK AND NETWORK EXTENDER INSTALLATION

Mounting

The device should be securely mounted to a vibration free surface. (See the "Specifications" section in this manual for device dimensions.)

Wiring

All devices on the LON are wired in a loop that starts and ends at the System Controller. To ensure proper operation, the LON should be wired using high speed communication grade cable.

NOTE

Cable meeting the specifications listed in Table 3-6 is suitable for distances up to 2000 meters.

Any of the cable types listed in Table 3-7 can be used for wiring the LON for the distances indicated.

NOTE

If no network extenders are used, the distances listed are for the entire loop. If network extenders are used, the distances listed are for the wiring length between network extenders or between a network extender and the System Controller.



IMPORTANT!

Det-Tronics recommends the use of shielded cable (required by ATEX) to prevent external electromagnetic interference from affecting field devices.



WARNING!

Be sure that the selected cable meets all job specifications and is rated for the installation per local and national codes and practices. The use of other cable types can degrade system operation. If necessary, consult factory for further suggested cable types.

Table 3-7—LON Maximum Cable Lengths

LON Cable (Manufacturer and Part No.)*	Maximum Length**	
	Feet	Meters
Belden 3073F (Tray Rated)	6,500	2,000
Det-Tronics NPLFP	6,500	2,000
Technor BFOU	4,900	1,500
Rockbestos Gardex Fieldbus***		
1 Shielded Pair, 16 AWG, Type TC, p/n FB02016-001	6,500	2,000
1 Shielded Pair, 18 AWG, Type TC, p/n FB02018-001	6,500	2,000

Note: *Use the same type of cable in each wiring segment between network extenders.

**Maximum wire lengths represent the linear wire distance of LON communications wiring between network extenders.

Be sure that selected cable meets all job specifications.

If necessary, consult factory for further suggested cable types.

***Cables designed to ISA SP50 Type A or IEC 61158-2 Type A are suitable for use in LON/SLC wiring. For armored version, contact cable manufacturer.

Table 3-6—Typical Specification for 16 AWG (1.5 mm²) LON Wiring Cable per Echelon

	Minimum	Typical	Maximum	Units	Condition
DC Resistance, each conductor	14	14.7	15.5	ohm/km	20 C per ASTM D 4566
DC Resistance Unbalanced			5%		20 C per ASTM D 4566
Mutual Capacitance			55.9	nF/km	per ASTM D 4566
Characteristic Impedance	92	100	108	ohm	64 kHz to 1 MHz, per ASTM D 4566
Attenuation	20 kHz		1.3	dB/km	20 C per ASTM D 4566
	64 kHz		1.9		
	78 kHz		2.2		
	156 kHz		3		
	256 kHz		4.8		
	512 kHz		8.1		
	772 kHz		11.3		
	1000 kHz		13.7		
Propagation Delay			5.6	nsec/m	78 kHz

T0049B

Length: 6,500 feet/2000 meters maximum (basic loop or between Network Extenders).

Type: Single twisted pair.

Wire Gauge: 16 AWG, stranded (19 x 29), tinned copper with overall shield.

Cables meeting these specifications are good for up to 2000 meters.

Table 3-8—Maximum Wiring Length from Nominal 24 vdc Power Source to Network Extender
(Maximum wire lengths are based upon the cable's physical and electrical characteristics.)

Wire Size	Maximum Wiring Distance	
	Feet	Meters
18 AWG (1.0 mm ²)*	2200	650
16 AWG (1.5 mm ²)*	3500	750
14 AWG (2.5 mm ²)*	5600	1700

*Approximate Metric Equivalent.

1. Remove the cover from the Network Extender enclosure.
2. Connect 24 vdc power lead wires and communication network cable to the terminal block. (See Figure 3-2 for terminal location and Figure 3-3 for terminal identification).

See Table 3-8 to determine maximum wiring length.

COM 1 - Communication network connections: Connect to COM 2 terminals of the next device on the loop, A to A and B to B.

COM 2 - Communication network connections: Connect to COM 1 terminals of the previous device on the loop, A to A and B to B.

24 VDC - Connect the "+" terminal to the positive side of the 24 vdc power source. (Both "+" terminals are connected internally.)

Connect the "-" terminal to the negative side of the 24 vdc power source. (Both "-" terminals are connected internally.)

3. Connect shields to the designated "shield" terminals. The two shield terminals are connected internally to ensure shield continuity.



Do not ground either shield at the network extender enclosure. Insulate the shields to prevent shorting to the device housing or to any other conductor.

4. Check ALL wiring to ensure that proper connections have been made.
5. Inspect the junction box O-ring to be sure that it is in good condition.
6. Lubricate the O-ring and the threads of the junction box cover with a thin coat of grease to ease installation and ensure a watertight enclosure.

NOTE

The recommended lubricant is a silicone free grease, available from Det-Tronics.

7. Place the cover on the enclosure. Tighten only until snug. **Do not over tighten.**

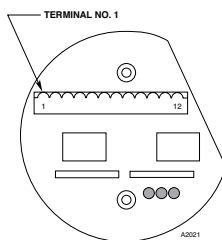

Figure 3-2—Network Extender Wiring Terminal Location

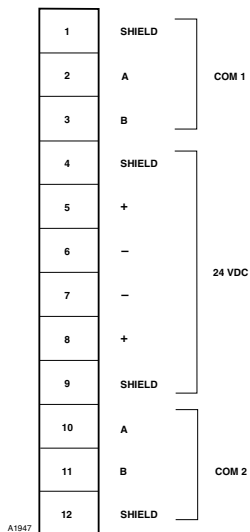

Figure 3-3—Network Extender Wiring Terminal Identification

INITIATING DEVICE CIRCUIT (IDC) INSTALLATION

EQ22XXIDC SERIES INITIATING DEVICE CIRCUIT (IDC)

The following paragraphs describe how to properly install the EQ22xxIDC Initiating Device Circuit.

Mounting

The device should be securely mounted to a vibration free surface. (See "Specifications" in this manual for device dimensions.)



WARNING!

The hazardous area must be de-classified prior to removing a junction box cover with power applied.

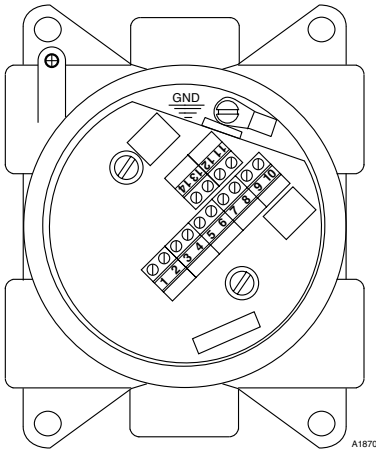

Figure 3-4—IDC Terminal Wiring Board Mounted in Six-Port Junction Box

Wiring

1. Remove cover from device junction box.
2. Connect external system wiring to the appropriate terminals on the terminal block. (See Figure 3-4 for terminal block location and Figure 3-5 for terminal identification). The input to the IDC consists of one or more normally open switches (momentary pushbuttons are not recommended), with a 10K ohm, 1/4 watt EOL resistor in parallel across the furthest switch from the input.



IMPORTANT!

An EOL resistor must be installed on both IDC inputs (including unused inputs). Wiring impedance must not exceed 500 ohms.

3. Check wiring to ensure that ALL connections have been properly made.



IMPORTANT!

Be sure that the keyed ribbon cable is properly connected to the terminal board.

4. Inspect the junction box O-ring to be sure that it is in good condition.
5. Lubricate the O-ring and the threads of the junction box cover with a thin coat of grease to ease installation and ensure a watertight enclosure.

NOTE

The recommended lubricant is a silicone free grease, available from Det-Tronics.

6. Set the node address for the device. (See "Setting Device Network Addresses" in this section.)
7. Place the cover on the junction box and tighten only until snug. **DO NOT over tighten.**

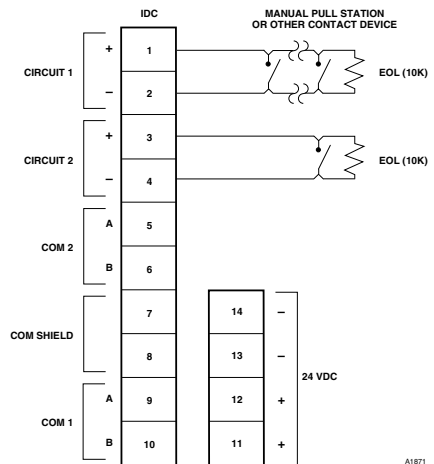

Figure 3-5—Terminal Configuration for IDC

EQ22XXIDCGF SERIES INITIATING DEVICE CIRCUIT GROUND FAULT

The following paragraphs describe how to properly install and configure the EQ22xxIDCGF Initiating Device Circuit Ground Fault.

Mounting

The device should be securely mounted to a vibration free surface. (See "Specifications" in this manual for device dimensions.)

Wiring



WARNING!

The enclosure must be electrically connected to earth ground.

1. Remove the enclosure cover from the device.
2. Remove the communication module from the junction box. Connect external wiring to the appropriate points on the device terminal block. (See Figure 3-4 for terminal block location and Figure 3-6 for terminal identification)
3. Check wiring to ensure that ALL connections have been properly made.

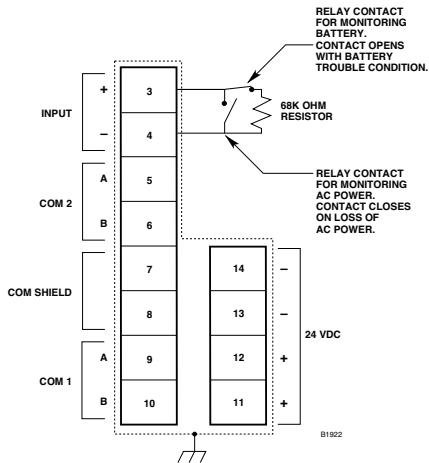

NOTE: ENCLOSURE AND/OR MOUNTING BRACKET MUST BE CONNECTED TO EARTH GROUND.

Figure 3-6—Terminal Configuration for IDCGF

4. Inspect the enclosure O-ring to be sure that it is in good condition. Lubricate the O-ring and the threads of the enclosure cover to ease both installation and future removal of the cover.

NOTE

The recommended lubricant is a silicone free grease available from Detector Electronics.



WARNING!

If the installation uses catalytic type combustible gas sensors, it is imperative that lubricants containing silicone not be used, since they will cause irreversible damage to the sensor.

5. Install the communication module in the device enclosure.

NOTE

Be sure the ribbon cable is properly connected.

6. Set the node address for the device. (See "Setting Device Network Addresses" in this section)

When configuring the EQ22xxIDCGF, its "device type" should be configured as an initiating device circuit (IDC).

Both inputs must be configured for a trouble condition.

Circuit 1 – "Open" indicates a -24 VDC ground fault condition. "Active" indicates a +24 VDC ground fault condition.

Circuit 2 – "Active" indicates a loss of AC input power. "Open" indicates a loss of battery power.

7. Place the cover on the enclosure and tighten until snug. **DO NOT over tighten.**

**EQ22xxIDCSC series initiating Device
Circuit Short Circuit (Not FM Approved)**

The following paragraphs describe how to properly install and configure the EQ22xxIDCSC Initiating Device Circuit Short Circuit.

Mounting

The device should be securely mounted to a vibration free surface. (See “Specifications” in this manual for device dimensions.)

Wiring



CAUTION!

The enclosure should be electrically connected to earth ground.

1. Remove the cover from the device enclosure.
2. Remove the communication module from the junction box. Connect external wiring to the appropriate terminals on device terminal block. (See Figure 3-4 for terminal block location and Figure 3-7 for terminal identification.) The input to the IDCSC consists of a normally open switch with a 3.3k ohm series resistor, and a 10K ohm, 1/4 watt EOL resistor in parallel across the switch.

NOTE

An EOL resistor must be installed on both IDCSC inputs (including unused inputs). Wiring impedance must not exceed 500 ohms. A 3.3K ohm resistor must be installed in series with the switch. For correct operation, only one switch per input can be connected.

3. Check wiring to ensure that ALL connections have been properly made.
4. Install the communication module in the device enclosure.
5. Inspect the enclosure O-ring to be sure that it is in good condition. Lubricate the O-ring and the threads of the enclosure cover to ease both installation and future removal of the cover.

NOTE

The recommended lubricant is a silicone

free grease available from Detector Electronics.

NOTE

Be sure the ribbon cable is properly connected.

6. Set the node address for the device. (See “Setting Device Network Addresses” in this section.)
7. Place the cover on the enclosure and tighten until snug. **Do not over tighten.**

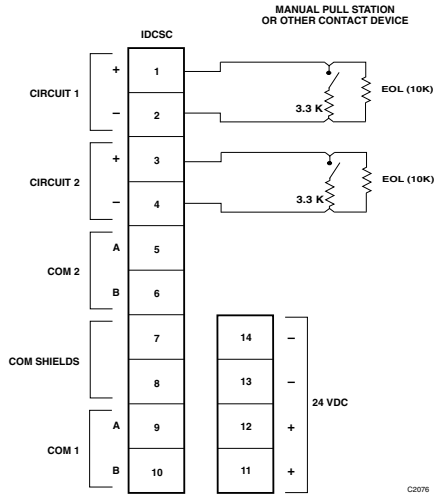

Figure 3-7—IDCSC Terminal Identification

**EQ3XXX CONTROLLER
INSTALLATION**

The following paragraphs describe how to properly install and configure the EQ3XXX Controller.

ENCLOSURE REQUIREMENTS

The Controller must be properly installed in a suitable enclosure that is rated for the location. The enclosure must provide space to install and wire the Controller and must also provide for ground wire termination. The enclosure must contain either a keyed lock or a special tool to gain access into the enclosure. The enclosure should be rated for the temperature range of the location plus the temperature rise of all equipment installed inside the enclosure.

The enclosure must be rated for electrical equipment that is going to be installed.

NOTE

The Controller and enclosure must be connected to earth ground.

For ordinary locations when entry is required to operate the equipment, the cabinet should be a dead-front construction and 16-gauge cold-rolled steel. The door lock system shall accept different keys for entry. An Authorized Persons key and a Person-in-charge key will allow entry into the cabinet. The cabinet should contain a window to view the Controller's text display and LED indicators.

NOTE

For any selected enclosure, the enclosure must conform to all applicable regulations and requirements.

NOTE

The Trouble signal must be located in an area where it is likely to be heard.

Classified locations require the appropriate hazardous rated enclosure. It is recommended that operators/switches be installed in the enclosure. This avoids the need to declassify the area in order to operate the Controller. Regulations require that key switches be installed for certain operations. An appropriate window should be part of the enclosure in order to allow an operator to view the text display and LED indicators.

NOTE

If an enclosure does not have a keyed entry, a special tool is required to gain entry into an enclosure.

Det-Tronics offers several approved (FM/CSA/ATEX/CE) hazardous area enclosures that have Eagle Quantum Premier equipment installed in the enclosure. Contact Det-Tronics for further information.

MOUNTING

The Controller is designed for direct panel mounting or DIN rail (optional) mounting. See "Specifications" section of this manual for mounting dimensions.

NOTE

Clips for DIN rail mounting are available, but must be specified at the time of ordering.

NOTE

A minimum clearance of 4 inches between the Controller and nearby equipment is required to provide room for wiring and ventilation.

SERIAL INTERFACE BOARD

A Serial Interface Board is available for the EQP Controller. See Figures 3-8A and 3-9 for details on the electrical connections.

ETHERNET INTERFACE BOARD

An Ethernet Interface Board is available for the EQP Controller. See Figures 3-8B and 3-9 for details on the electrical connections.

WIRING

Power Wiring



CAUTION!

Input voltage at the Controller must be 18 vdc minimum to ensure proper operation.

It is important to consider both the wire gauge and the distance from the Controller to the power supply. As the distance between the Controller and the power supply increases, so must the diameter of the power wiring in order to maintain a minimum of 18 vdc at the Controller.



IMPORTANT!

To ensure proper operation of devices, the voltage input to the device (measured at the device) must be within the range indicated for that device in the "Specifications" section of this manual.

Electrical Connections

Figure 3-8 shows the location of wiring connectors on the Controller module. Figure 3-9 identifies individual terminals.

Connector P1, Terminals 1 to 4 — 24 vdc Input Power

Connect the power supply to terminals 1 and 2 of the Controller. Terminals 3 and 4 must also be connected to power.

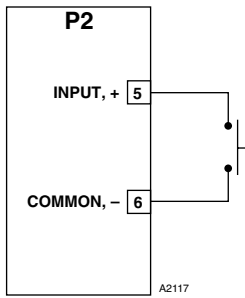

Figure 3-10—Unsupervised Input Wiring

When controller and power supplies are installed in separate NRTL cabinets, two power cables from two distribution circuits are required, so that if one is lost, the controller will continue to operate and signal a trouble condition. The power circuit must be protected against physical damage.

Shields on power cables must be connected to chassis ground (earth).

Connector P2, Terminals 5 to 12 — Unsupervised Digital Input Channels 1 to 4

Connector P3, Terminals 13 to 20 — Unsupervised Digital Input Channels 5 to 8

See Figure 3-10 for example. Only channel 1 is shown in Figure 3-10. The information is typical for channels 2-8.

Connector P4, Terminals 21 to 32 — Unsupervised Relay Output Channels 1 to 4

Connector P5, Terminals 33 to 44 — Unsupervised Relay Output Channels 5 to 8

See Figure 3-11 for example. Only channel 1 is shown in Figure 3-11. The information is typical for channels 2-8.

NOTE

Channel software configurations include all panel indicator functions to automatically mimic the controller front panel indicators.

Connector P6, Terminals 45, 46 & 47 — Trouble Relay

The Trouble relay is not configurable. In the normal condition, the relay coil is energized,

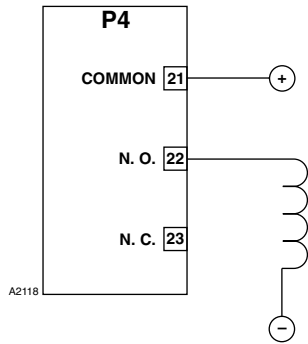

Figure 3-11—Unsupervised Relay Output

closing the N.O. contact (terminals 45-46) and opening the N.C. contact (terminals 45-47). The relay coil is de-energized in the trouble condition.

Connector P7, Terminals 48 to 53 — LON Signaling Line Circuit Terminals

The LON loop is wired so that the controller's LON COM 1 is connected to the field device's COM 2 connection. The field device's COM 1 is wired to the next device's COM 2 connection. This continues through the last field device on the loop. The last field device's COM 1 is then wired back to the Controller's COM 2 connection. LON A and B polarities must be maintained throughout the loop (i.e., always wire A to A and B to B between the devices).

Port Pinout (6-position connection terminal block)

- 48 — COM 1 shield connection
- 49 — "B" side of signaling circuit for COM 1
- 50 — "A" side of signaling circuit for COM 1
- 51 — COM 2 shield connection
- 52 — "B" side of signaling circuit for COM 2
- 53 — "A" side of signaling circuit for COM 2

NOTE

Refer to Figures 3-12A and 3-12B for location of termination jumpers.

Jumper P24 – RS-485 Termination Jumper

- 1-2 Underterminated
- 2-3 Terminated 121 ohms (factory setting)
Transceiver input impedance: 68 kohm

Jumper P25 – LON COM 1 Termination

- 1-2 COM 1 Terminated (factory setting)
- 2-3 COM 1 Underterminated (Redundancy)

Connector P9, Terminals 57, 58 & 59 — S³ Configuration Port

Configuration data downloaded into the controller configures the serial interface transmission baud rate and parity check for the serial port. Software selectable baud rates are 2400, 4800, 9600, 19200, 38400, 57600, and

115200 (factory default is 115200). Software selectable parity is None, Odd, and Even.

Port Pinout (3-position terminal block)

- 57 — GND
- 58 — RXD
- 59 — TXD

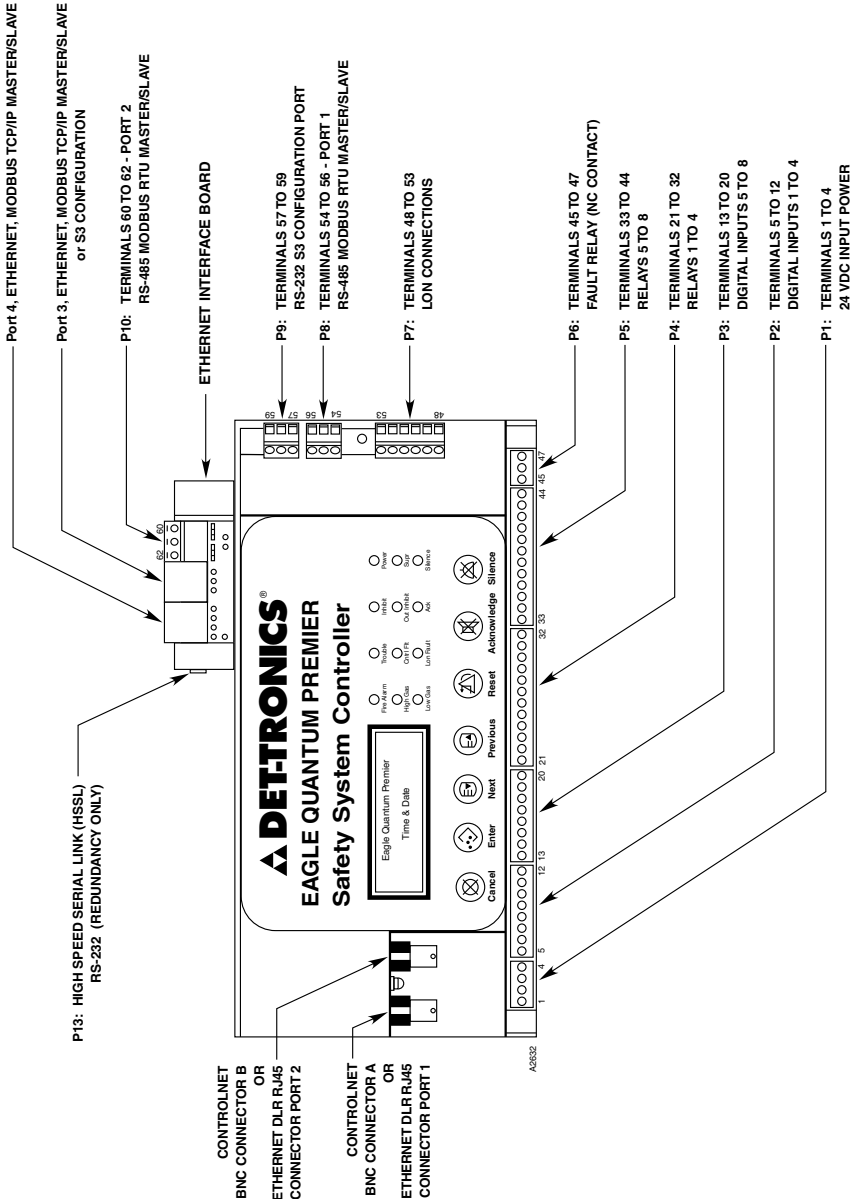

Figure 3-8B—Location of Wiring Terminals on EQP Controller with Ethernet Interface Board

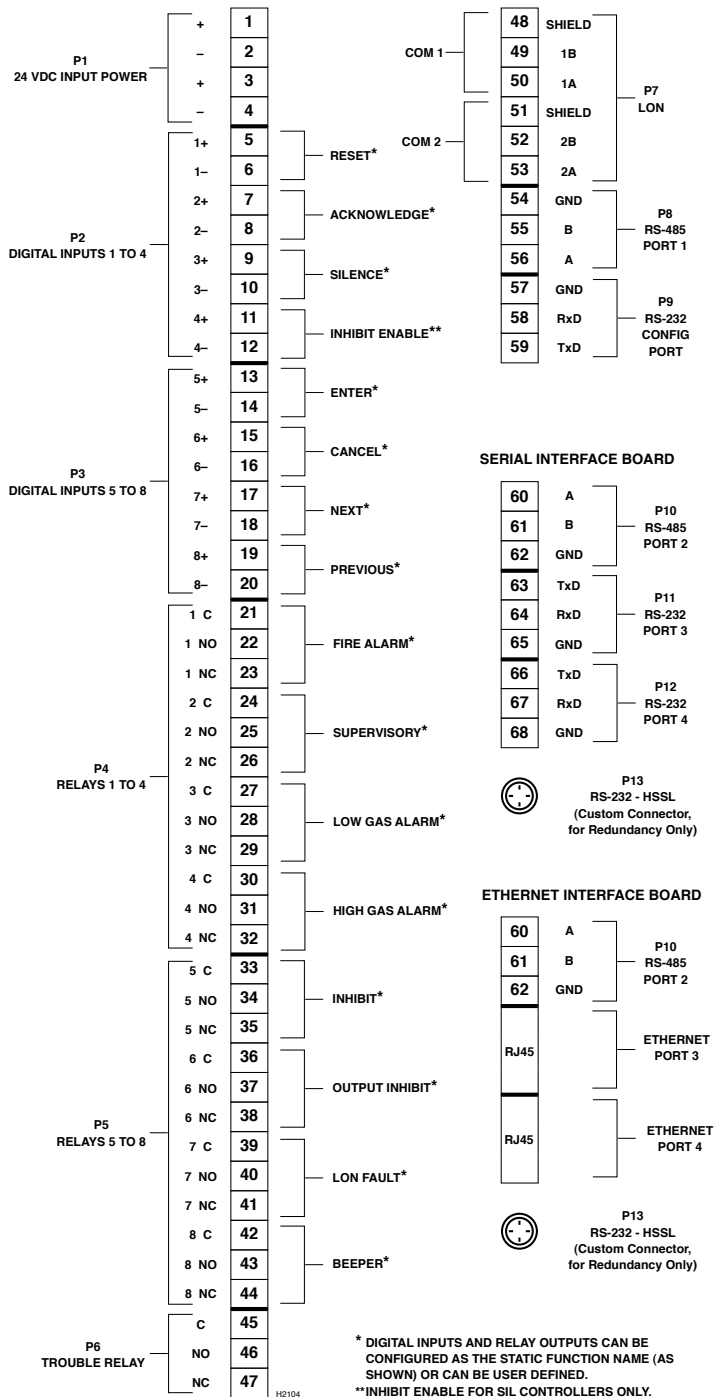

Figure 3-9—EQP Controller Terminal Identification

Connector P10, Terminals 60, 61 & 62, Port 2 – RS-485 Modbus RTU Master/Slave

Configuration data downloaded into the controller configures the serial interface transmission baud rate, parity check for the serial port, and Modbus device address. Software selectable baud rates are 9600, 19200, 38400, 57600, 115200 and 230400. Software selectable parity is None, Odd, and Even. The controller uses 8 data bits with 1 stop bit.

Port Pinout (3-position terminal block)

- 60 — A
- 61 — B
- 62 — GND

Serial Interface Board Jumpers

Jumper P25 – RS-485 Termination Jumper, Port 2

- 1-2 Terminated 121 ohms (factory setting)
- 2-3 Unterminated
Transceiver input impedance: 68 kohm

Jumper P3 – RS-485 Ground Fault Monitor, Port 2

- 1-2 Enabled
- 2-3 Disabled (factory setting)

Ethernet Interface Board Jumpers

Jumper P6 – RS-485 Termination Jumper, Port 2

- 1-2 Terminated 121 ohms (factory setting)
- 2-3 Unterminated
Transceiver input impedance: 68 kohm

Jumper P5 – RS-485 Ground Fault Monitor, Port 2

- 1-2 Enabled
- 2-3 Disabled (factory setting)

Use Port 2 to pass safety critical information between controllers. Ensure that Ground Fault Monitoring is enabled. User logic can pass all alarm, trouble, and supervisory information between the controllers. Watchdog timers must be implemented in user logic to verify the integrity of the SLC. Consult the local authority having jurisdiction for annunciation requirements.

CONTROLLER TO CONTROLLER COMMUNICATION

Controller to Controller Communication (SLC485) with Signaling Line Circuit Classification Class B or X, per NFPA 72

To connect up to twelve controllers together and be able to transfer safety information between the controllers, the communication link must be classified as a signaling line circuit per NFPA 72. With the Serial Interface Board, Port 2 (plug 10) is a RS-485 serial connection that is ground fault monitored.

To meet the signaling line circuit (Class B or Class X) requirements, the following must be configured for correct operation:

- All controllers must have the same type Interface Board (Ethernet or Serial) installed.



CAUTION

When using the Ethernet Interface Board, controllers communicating over P10, Port 2 - RS-485 are required to be located within the same room or be wired in conduit within 20 feet (6 meters) for signalling line transient protection.

- The Termination jumper P28 must be set to Terminate (position 1-2) on all controllers.
- The Ground Fault Monitor jumper P29 must be set to Enabled (position 1-2) on all controllers.
- For Class X, Connect terminals A (# 56) and B (# 55) between the controllers. Connect terminal A (# 60) and B (# 61) between controllers using a different cable route. Connect GND (# 54) to GND (# 62) on each controller.
- For Class B, connect terminals A (terminal number 60) and B (terminal number 61) between the controllers. The GND (terminal number 62) must not be connected.

See Figure 3-13A and 3-13B for wiring details.

Note 1: 56.7 kbps minimum and 115.2 kbps maximum baud rate required for proper communication.

Note 2: Consult the factory for configuration set-up.

Note 3: Maximum SLC485 length over copper not to exceed 1000 meters.

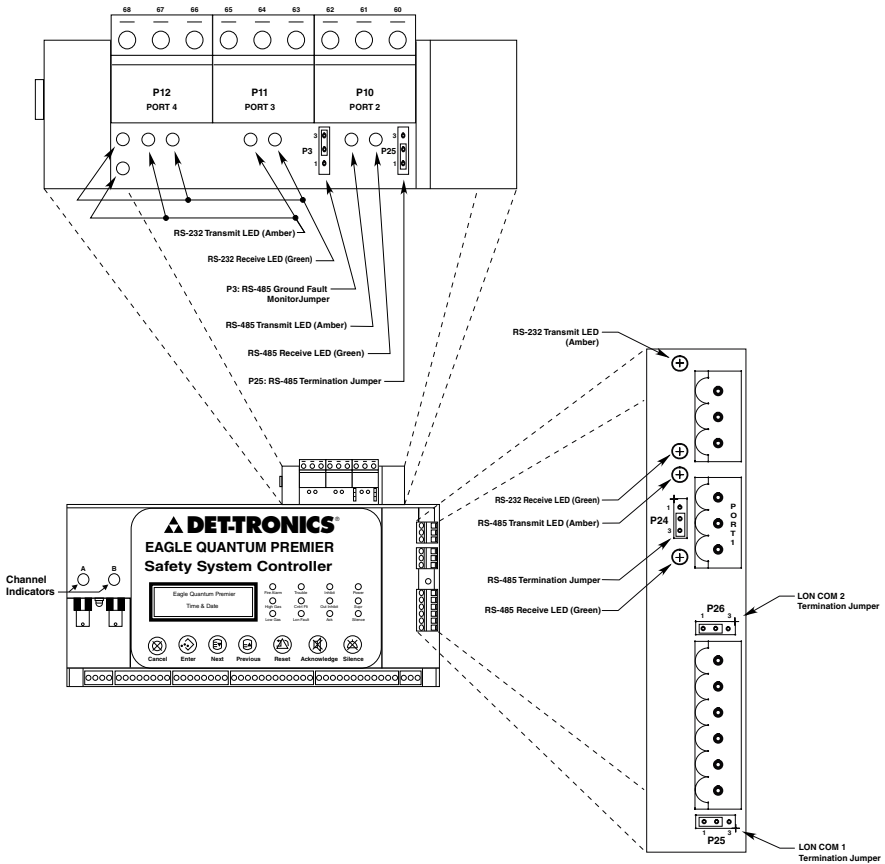

Figure 3-12A—Location of Termination Jumpers, Communication Indicator LEDs, and Communication Ports for Controller with Serial Interface Board

Manufacturer	Model Number	Description
Moxa (www.moxa.com)	TCF-142-S	RS-485 to Single-mode Fiber Optical Converter
Phoenix Contact	PSI-MOS-RS485W2/FO	RS-485 to Multi-mode Fiber Optical Converter

Table 3-9—Approved Supported Media Converters for Fiber Optical Link

Controller to Controller with Fiber Optic Link, Signal Line Circuit Classification Class B or X per NFPA 72.

Up to twelve EQP controllers (single or redundant pair) can be inter-connected via a fiber optic link. This communication link is classified as a signaling line circuit per NFPA

72 to allow safety information to be transferred between controllers.

The fiber optic link incorporates media converters to convert from copper to fiber optic cable. The converter must be located in the same cabinet as the controller and cannot use ground fault monitoring. The approved supported converters are shown in Table 3-9. The link budget for the listed fiber optic converters is 10dB.



WARNING

The fiber converters must be mounted inside the same enclosure as the controllers to conform to NFPA 72.

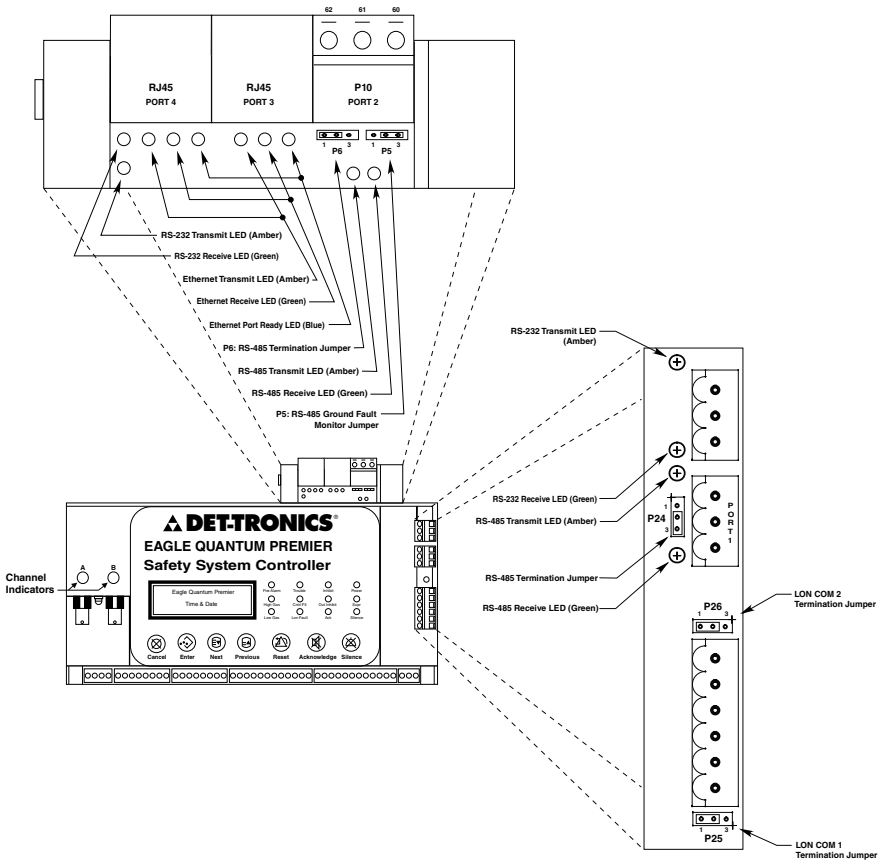

Figure 3-12B—Location of Termination Jumpers, Communication Indicator LEDs, and Communication Ports for Controller with Ethernet Interface Board

The media converter can be connected to either of the EQP controller RS-485 communication ports (Port 1 or Port 2). Figure 3-14 illustrates a typical Class B wiring connection (single mode) between two EQP controllers in a redundant configuration using Port 1. Note: If Port 2 is preferred, the Serial Interface Board must be purchased.

Figure 3-15 shows a typical Class X wiring connection (single mode).

Figure 3-16 shows a typical Class X wiring connection for Phoenix (multi mode).

For more information regarding selection and installation of fiber optic media, please contact Det-Tronics customer service.

The maximum distance of a particular optic link given the optical budget is calculated as:

$$\text{Fiber Length} = \frac{[\text{Optical budget}] - [\text{Link Loss}]}{[\text{Fiber Loss / km}]}$$

where link loss includes number of end connectors, splices and safety margin.

Example: 10 db link budget
 Cable Attenuation: 0.4 db / km
 2 connectors: (1 each end) with 0.5 db ea.
 Safety margin: 3.0 db max

$$\text{Max. Distance} = \frac{10 - (2 \times 0.5) - 3.0}{0.4} = 15 \text{ km}$$

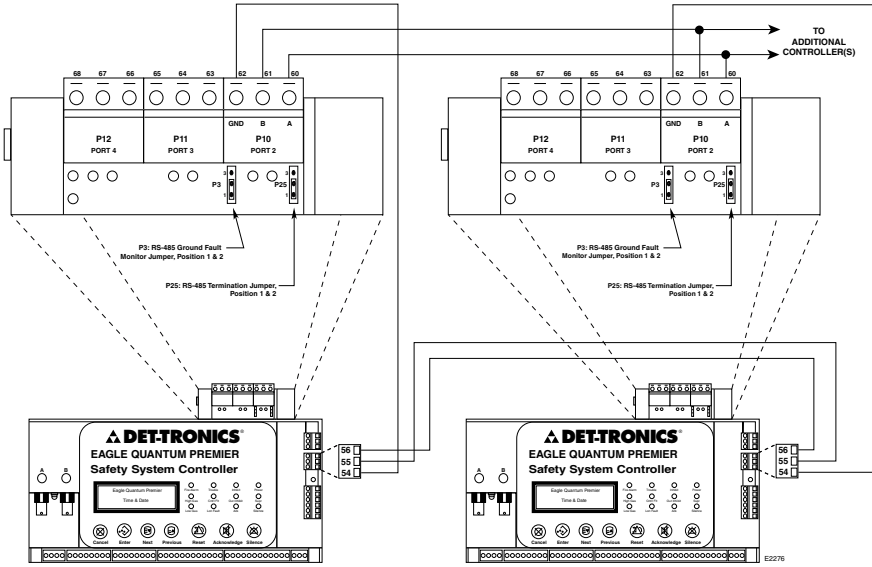

Figure 3-13A—Controller to Controller Communication with Class A Signaling Line Circuit Classification per NFPA 72, for Controllers with Serial Interface Board

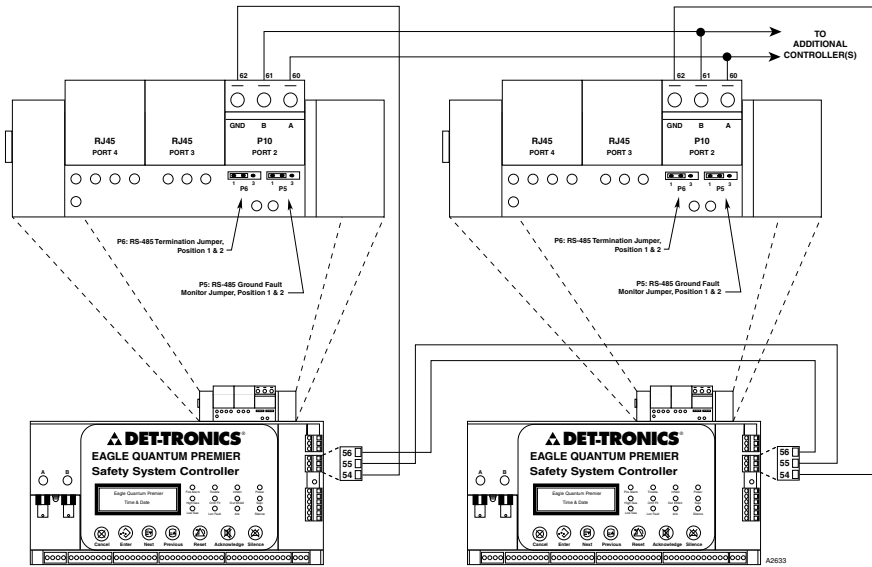

Figure 3-13B—Controller to Controller Communication with Class A Signaling Line Circuit Classification per NFPA 72, for Controllers with Ethernet Interface Board

**Connector P11, Terminals 63, 64 & 65, Port 3—
(Serial Interface Board only)
RS-232 Modbus RTU Master/Slave or S³
Configuration Port (Non-Isolated)**

Configuration data downloaded into the controller configures the serial interface transmission baud rate, parity check and MODBUS device address for the serial port. Software selectable baud rates are 9600,19200, 38400, 57600, 115200, and 230400. Software selectable parity is None, Odd, and Even. The controller uses 8 data bits with 1 stop bit.

Port Pinout (3-position terminal block)
63 — TXD
64 — RXD
65 — GND

**RJ45, Port 3
(Ethernet Interface Board only)
Ethernet Modbus TCP Client/Server
or S³ Configuration Port (Non-Isolated)**

Configuration data downloaded into the controller configures the Ethernet interface IP address, subnet mask, gateway, and local port number. This port may be used as a Modbus TCP Client or a Modbus TCP Server. This port may also be used as an alternate S³ configuration port. EQP controllers come from the factory with the following default values for Port 3:

Port 3	IP Address	192.168.127.251
Port 3	Subnet Mask	255.255.255.000

NOTE

Maximum Modbus update time per port is 250 mSec.

**Connector P12, Terminals 66, 67 & 68, Port 4—
(Serial Interface Board only)
RS-232 Modbus RTU Master/Slave
(Non-Isolated)**

Configuration data downloaded into the controller configures the serial interface transmission baud rate, parity check and MODBUS device address for the serial port. Software selectable baud rates are 9600,19200, 38400, 57600, 115200, and 230400. Software selectable parity is None, Odd, and Even. The controller uses 8 data bits with 1 stop bit.

Port Pinout (3-position terminal block)
66 — TXD
67 — RXD
68 — GND

**RJ45, Port 4
(Ethernet Interface Board only)**

Ethernet Modbus TCP Client/Server
Configuration data downloaded into the controller configures the Ethernet interface IP address, subnet mask, gateway, and local port number. This port may be used as a Modbus TCP Client or a Modbus TCP Server. EQP controllers come from the factory with the following default values for Port 4:

Port 4	IP Address	192.168.127.252
Port 4	Subnet Mask	255.255.255.000

NOTE

Maximum Modbus update time per port is 250 mSec.

**Connector P13 —
RS-232 High Speed Serial Port**

This port is dedicated to inter-controller connection required for redundancy, and is not available for any other use. This port is automatically configured.

CONFIGURATION

Software Defined Addresses

Det-Tronics Safety System Software (S³) is programmed with the addresses that are assigned to the controller when the configuration file is downloaded into the controller. Addresses define and configure the Controller's LON address, Modbus slave address, ControlNet option board address, and Ethernet DLR option board address. Each device on the LON must be assigned a unique tag number. This tag number must include zone designation, which will be shown on the Controller's display when the device is in alarm.

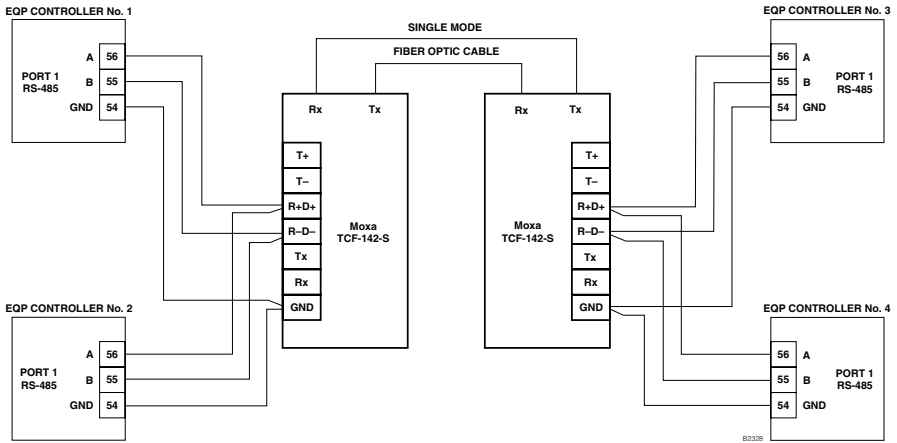

Figure 3-14—Controller to Controller NFPA 72 Approved Fiber Optic Link, Class B

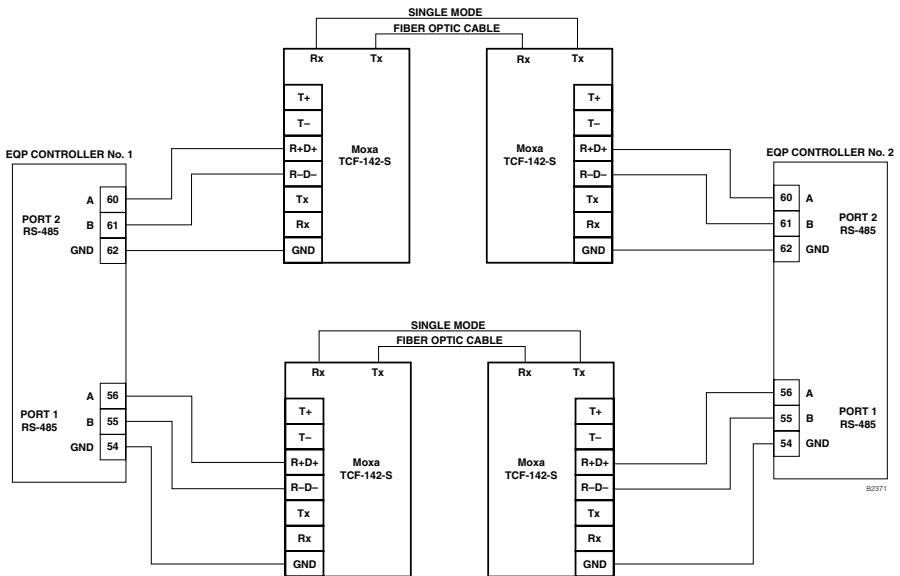

Figure 3-15—Single Mode Controller to Controller NFPA 72 Approved Fiber Optic Link, Class X

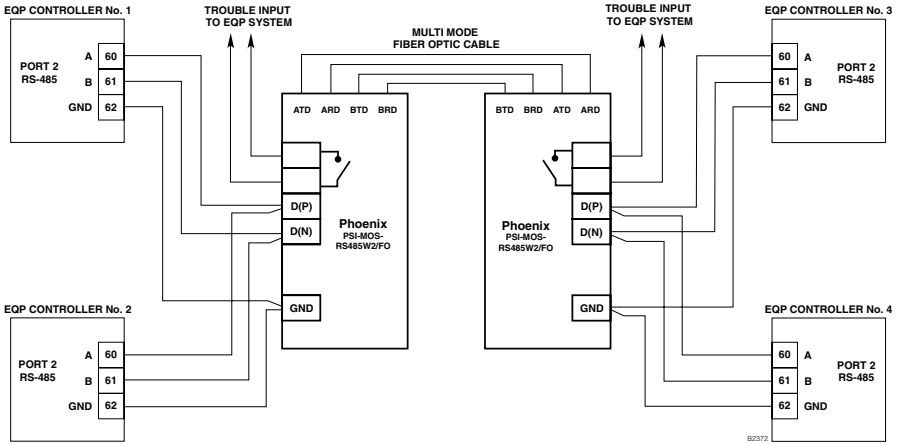

Figure 3-16—Multi-Mode Controller to Controller NFPA 72 Approved Fiber Optic Link, Class X

EQ3XXX REDUNDANT CONTROLLER INSTALLATION

The redundant controllers must be purchased with the following options for correct installation:

- Either Ethernet or Serial Interface Board
- High-speed serial cable
- LON termination modules (2).

ENCLOSURE REQUIREMENTS

The redundant controllers must be located next to each other in the same enclosure (4 ft. interconnecting cable).

MOUNTING

The controllers are designed for direct panel mounting or DIN rail mounting. See "Specifications" section of this manual for mounting dimensions.

WIRING

The redundant controllers are wired the same as a simplex controller except for the LON wiring and the dedicated high-speed serial link, which are defined below. Refer to EQ3XXX Controller Installation for general installation details.

LON WIRING

The LON must be connected to both redundant controllers to ensure correct operation. Two LON Termination Modules are required for the installation as shown in Figure 3-17.

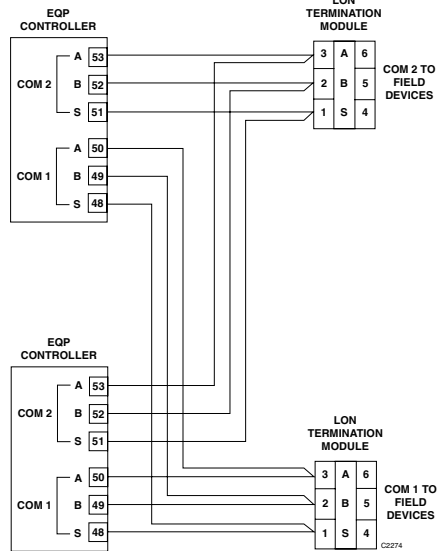

NOTE: LON TERMINATION JUMPERS P25 AND P26 (SEE FIGURE 3-12) MUST BE IN POSITION 2 AND 3 FOR REDUNDANT CONFIGURATION (ON BOTH CONTROLLERS).

Figure 3-17—LON Connection for Redundant EQP Controllers

HIGH SPEED SERIAL LINK (HSSL)

The redundant controllers are connected together by a dedicated high-speed serial link. This link is a pre-fabricated cable that has a custom connector for ease of use. Redundant controllers are automatically addressed with the HSSL cable. One end of the cable is labeled Primary. The primary controller takes address 1, while the secondary controller is address 2. The significance this has for the user is that the primary is the default master when both controllers are powered-up at the same time.

CONFIGURATION

S³ Configuration

The S³ configuration software is used to configure the redundant controllers. A check box on the controller configuration screen must be enabled and downloaded to the controllers.



IMPORTANT

If the controllers have not been configured for redundancy via the S³ configuration software, redundancy will not function.

Controller Addresses

The LON addresses are pre-determined and cannot be adjusted. Address 1 and 2 have been reserved for a redundant controller configuration.

RS485/RS232 (Port 1 through Port 4)

RS485/RS232 ports 1 through 4 on each controller share the serial settings including baud rate and address. Controllers in standby mode don't respond to or issue Modbus RTU messages. This allows for transparent switching on a multi-drop network. If RS-232 is used, a relay switching mechanism can be used.

ControlNet

The ControlNet interface on each controller will have a different address. This allows both controllers to reside on the same ControlNet network at the same time. The primary controller uses the configured address while the standby assumes an address 1 higher than the primary controller. Application logic in the attached PLC must be used to determine which

controller has the correct output information. Information coming from the PLC should be written to both Premier Controllers.

Ethernet DLR

The Ethernet DLR interface on each controller will have a different address. This allows both to reside on the same network at the same time. The primary controller uses the configured address while the standby assumes an address 1 higher than the primary controller. Application logic in the attached PLC must be used to determine which controller has the correct output information. Information coming from the PLC should be written to both Premier Controllers.

Ethernet

The Ethernet interface ports on each controller will all have unique IP addresses. This allows both controllers to reside on the same Ethernet network at the same time. The primary and secondary controller IP addresses for ports 3 and 4 are part of the configuration data. During the configuration download, the primary controller assigns the primary IP address to itself and passes the secondary IP address on to the secondary controller. Controllers in standby mode do not respond to Modbus TCP/IP messages. Ethernet applications need to redirect to the alternate IP address when controller switchovers occur.

EQ21XXPS SERIES POWER SUPPLY AND POWER SUPPLY MONITOR INSTALLATION



WARNING!

ALWAYS follow all safety notes and instructions when installing power supply or batteries!



WARNING!

Make sure a.c. power is OFF at main a.c. breaker before beginning power supply installation!



IMPORTANT!

Power supplies require unrestricted air flow for proper cooling.

MOUNTING

Mount the power supply monitor in a Nationally Recognized Test Laboratory (NRTL) labeled enclosure. Refer to the "Specifications" section for mounting dimensions.

WIRING



CAUTION!

The power supply should be properly connected to an earth ground! A ground wire MUST be connected to the power supply units's case ground!

NOTE

The Power Supply Monitor uses two of the four DIP switches to select an appropriate fault level for the installation. See Figure 3-18. The unit will fault when the batteries source a current level higher than the threshold for 20 seconds. The fault will clear when the current drops to half the level for 20 seconds. The current level selection is based on the minimum current draw of the attached equipment. The selected value must be less than the actual minimum current draw for the system.

1. Verify that the input source is the same voltage and frequency as that marked on the nameplate of the power supply.
2. Verify that transformer taps are set for the correct a.c. input. (Input tap setting is located inside the power supply enclosure.)
3. Verify that the supply power wire size and fusing are adequate for the current indicated on the power supply nameplate.

NOTE

Consult the power supply manufacturer's instruction manual provided with the support documentation received with the Eagle Quantum System.

NOTE

Required Overload Current is usually equal to 15% of the nominal rating.

4. Connect external wiring to the appropriate points on Power Supply. Refer to Figure 3-18 for terminal block locations and Figures 3-19 and 3-20 for terminal identification. Connect the 24 vdc power wires and the LON network cable to the appropriate points on J1. (Redundant "+", "-", and shield terminals are connected internally.) **Do not** ground any shield at the monitor / power distribution cabinet. Insulate the shields to prevent shorting to the device housing or to any other conductor.
5. Connect a two wire cable between the AC input of the power supply and terminals 1 and 4 on J3, the AC input terminal block on the power supply monitor. See Figure 3-20.
6. Connect the "B" terminal on the power supply monitor to the negative (-) side of the backup battery. Connect a correctly sized circuit breaker in the battery circuit as shown in Figure 3-21. The circuit breaker must be rated between 130% and 250% of the total load.
7. Connect the "C" terminal on the power supply monitor to the negative (-) side of the power supply.
8. Wire the power distribution circuit breakers to the output of the power supply. Circuit breaker ratings must be between 130% and 250% of the full load rating.
9. Set the device network address for the power supply monitor.

NOTE

For additional information, refer to the power supply manufacturer's instruction manual provided with the support documentation received with the Eagle Quantum Premier system.

STARTUP

Turn on the power supply and allow the voltage to stabilize at 27 volts before closing the circuit to the battery.

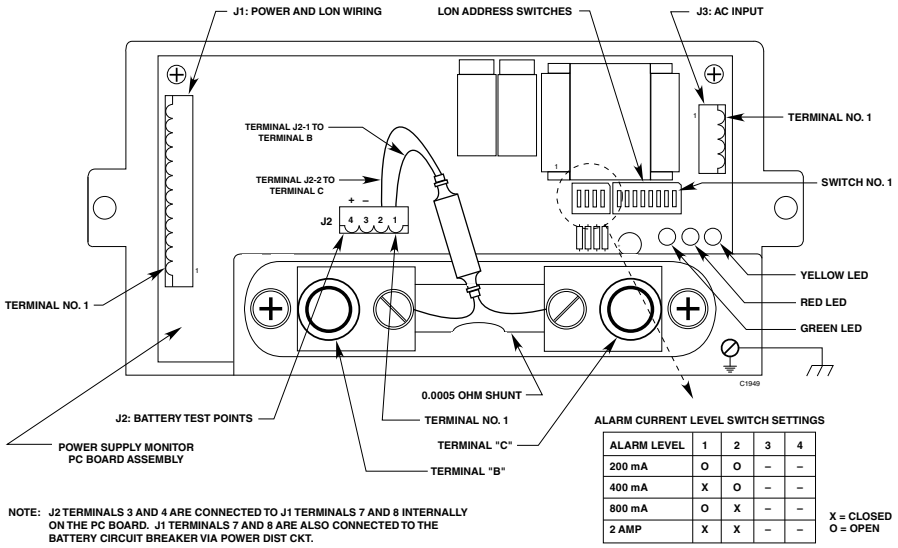

Figure 3-18—Power Supply Monitor Terminal and Switch Location

MEASURING BATTERY VOLTAGE AND CHARGING CURRENT

Measure the battery voltage at terminals 3 and 4 of terminal block J2. See Figure 3-18 and 3-22.

To measure the battery charging current, connect a digital voltmeter to terminals 1 and 2 of terminal block J2. The voltmeter will read 1 millivolt (0.001 volt) for each 2 amperes of current.

Current in Amperes = Meter reading in millivolts x 2

Example: A reading of 50 millivolts indicates a charging current of 100 amperes.

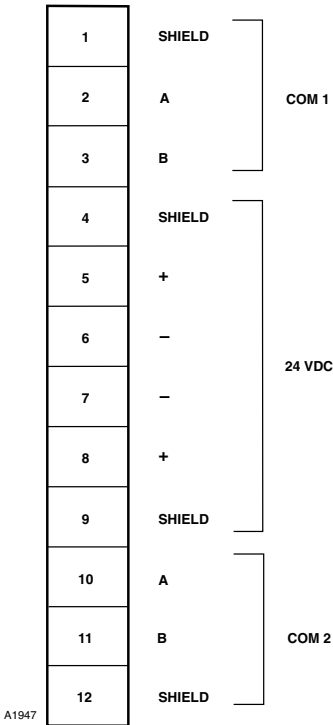

A1947

Figure 3-19—J1: Power and LON Wiring Terminal

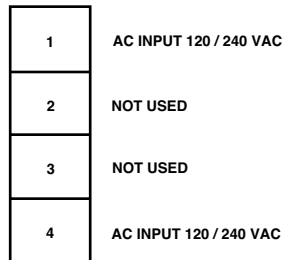

A1950

Figure 3-20—J3: AC Input Terminal

1. Connect external wiring to the appropriate points on Power Supplies.

Refer to Figure 3-23A for terminal locations for EQP21X0PS(-X).

Refer to Figure 3-23B for terminal locations for EQP2410PS(-P) Converter.

Refer to Figure 3-23C for terminal locations for EQP2120PS(-X) with EQP2410PS(-P) Converter.

2. Connect the 24 VDC output to the Redundancy Module. (Redundant “+” and “-” power supply terminals are connected internally.)
3. To ensure compliance with NFPA 72, primary and secondary power supplies shall be monitored for the presence of voltage at the point of connection to the system. Connect the power supply unit for preferred preventive function monitoring. Refer to Figure 3-24 for an example of power supply relays wired in series for power monitoring.

NOTE

Contacts are closed during normal operation. The circuit shall be wired to an input on the EQP system (EDIO or IDC). In Logic, the selected input must be inverted and used to activate an alarm trigger gate, which initiates a fault message on the Controller and activates the fault relay output.

No supervision is necessary, since the EDIO or IDC module must be installed in the same cabinet with EQP21X0PS and EQP2410PS.

For USCG Approved System monitoring details, refer to Appendix D.

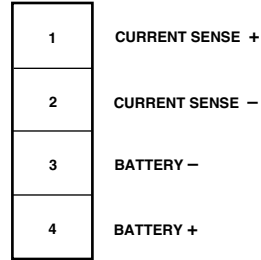

A1952

Figure 3-22—J2: Battery Test Points

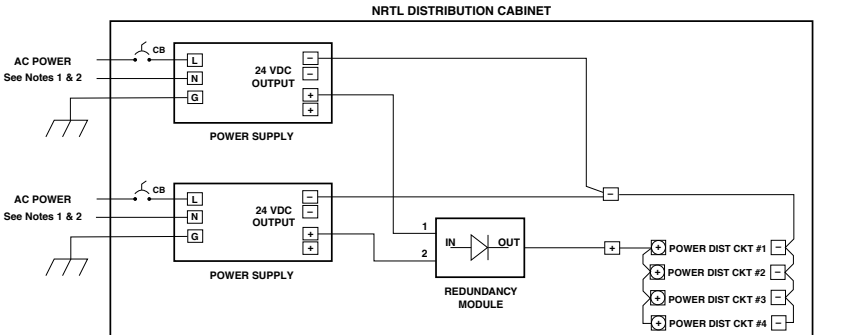

- NOTES:
1. AC INPUT IS AUTO-SELECTABLE FOR 120-220 VAC, 60/50 Hz (CUSTOMER SUPPLIED).
 2. PRIMARY SOURCE OF INPUT SUPPLY IS CONNECTED TO ONE POWER SUPPLY AND SECONDARY SOURCE IS CONNECTED TO THE OTHER.
 3. A MAXIMUM OF 8 REDUNDANT PAIRS CAN BE CONNECTED TO INPUT AC POWER.
 4. THE SECONDARY SOURCE IS CONTINUOUSLY POWERED.
 5. EQP CONTROLLER MUST BE INSTALLED IN THE SAME ENCLOSURE AS AC-DC POWER SUPPLIES AND REDUNDANCY MODULE.

Figure 3-23A—Wiring Connections for an EQP21X0PS(-X) Power Supply (Typical)

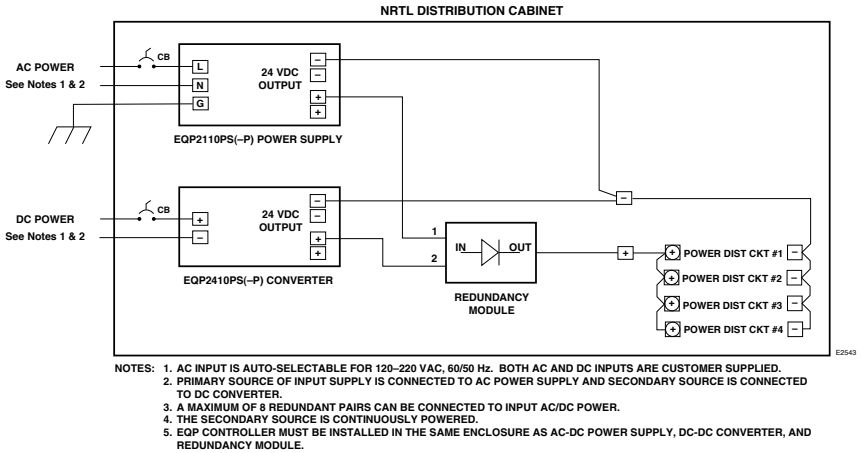

Figure 3-23B—Wiring Connections for an EQP2110PS(-P) Power Supply with EQP2410PS(-P) Converter (Typical)

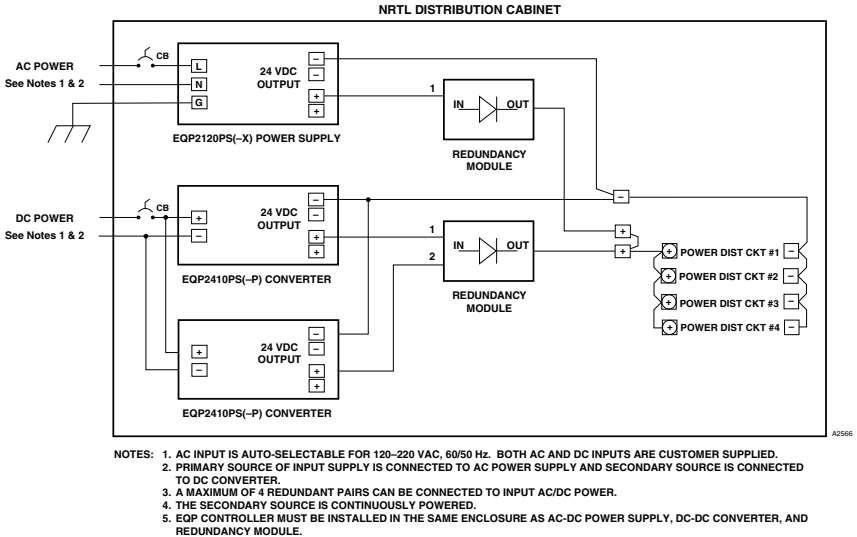

Figure 3-23C—Wiring Connections for One EQP2120PS(-X) Power Supply with Two EQP2410PS(-P) Converters (Typical)

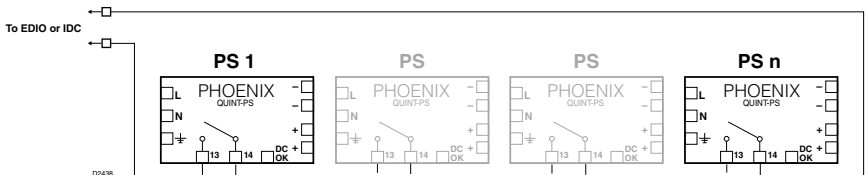

Figure 3-24—Power Supply and Converter Relays Wired in Series for Trouble Monitoring (up to 16 Power Supplies/Converters)

NOTE

For additional information, refer to the power supply manufacturer's documents provided with the support documentation received with the Eagle Quantum Premier system.

STARTUP

Turn on the power supply and allow the voltage to stabilize. Verify the output voltage and adjust as needed. Refer to "EQP2XX0PS(-X) Power Supplies" in the Specifications section of this manual.



IMPORTANT!

The output voltage is adjustable. An even current distribution must be ensured by precisely setting all power supply units that are operated in parallel to the same output voltage ± 10 mV.



IMPORTANT!

To ensure symmetrical current distribution it is recommended that all cable connections from all power supply units/diode redundancy modules to the power distribution bus are the same length and have the same cross section.

ENHANCED DISCRETE INPUT/OUTPUT (EDIO) MODULE INSTALLATION

All electrical connections are made to the field wiring connectors furnished with the module. Refer to Figure 3-25 for identification of module wiring terminals.

**Connector P1, Terminals 1 to 6
24 Vdc Power Input**

Connect the module power supply to terminals 1 and 2. If additional terminals are required for powering other devices, these devices should be connected to terminals 4 and 5. Shields are to be connected to terminals 3 and 6 — chassis (earth) ground terminals. Total output current should be limited to 10 amperes.

**Connector P2, Terminals 1 to 6
LON/SLC Signaling Circuit Terminals**

Be sure to observe polarity when wiring the LON/SLC.

- 1 — "A" side of signaling circuit for COM 1
- 2 — "B" side of signaling circuit for COM 1
- 4 — "A" side of signaling circuit for COM 2
- 5 — "B" side of signaling circuit for COM 2
- 3, 6 — shield connection

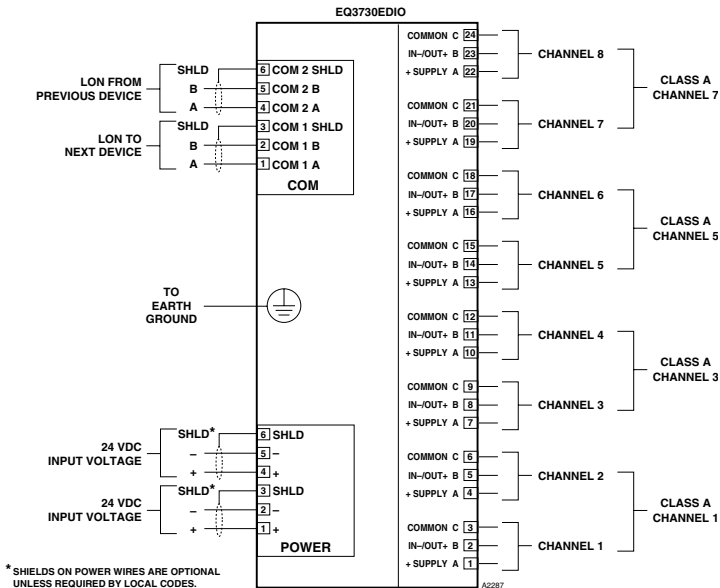

Figure 3-25—EDIO Module Wiring Terminals

Connector P3, Terminals 1 to 12
Terminals A, B & C
Channels 1 to 4 Input / Output Terminals

Refer to individual wiring configurations for terminal descriptions. Only channel 1 is shown in each diagram. The information is typical for channels 2-8.

Connector P4, Terminals 13 to 24
Terminals A, B & C
Channels 5 to 8 Input / Output Terminals

Refer to individual wiring configurations for terminal descriptions. Only channel 1 is shown in each diagram. The information is typical for channels 2-8.

Unsupervised Input

Connect external system wiring to the appropriate terminals on the terminal block. See Figure 3-26.

The input to the EDIO consists of one or more normally open or normally closed switches. An EOL resistor is not required.

Make no connection to “+ Supply” terminal.

Supervised Input (IDC) Open Circuit Supervision

Connect external system wiring to the appropriate terminals on the terminal block. For Class B wiring, see Figure 3-27. For Class A wiring, see Figure 3-28. Note that two channels are used for one circuit when using Class A wiring.

The input to the EDIO module consists of one or more normally open switches, with a 10 K ohm, 1/4 watt EOL resistor in parallel across the last switch.

Make no connection to “+ Supply” terminal.

Supervised Input Open and Short Circuit Supervision

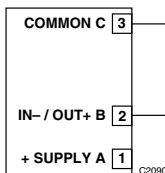

Figure 3-26—Unsupervised Input Configuration

Connect external system wiring to the appropriate terminals on the terminal block. For Class B wiring, see Figure 3-29. For Class A wiring, see Figure 3-30. Note that two channels are used for one circuit when using Class A wiring. Both wiring configurations provide indication of open and short circuit fault.

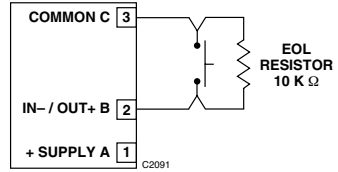

Figure 3-27—Supervised Input Configuration – Class B

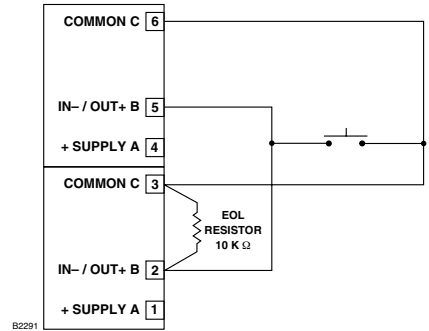

Figure 3-28—Supervised Input Configuration – Class A

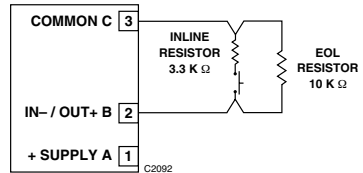

Figure 3-29—Supervised Input Configuration for Opens and Shorts – Class B

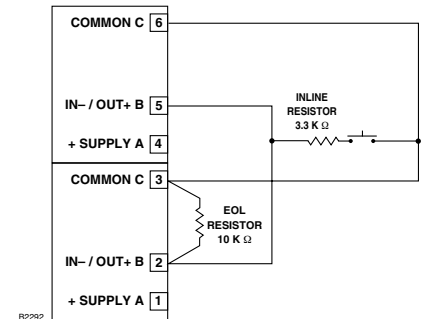

Figure 3-30—Supervised Input Configuration for Opens and Shorts – Class A

The input to the EDIO module consists of normally open switches, with a 10 K ohm, 1/4 watt EOL resistor in parallel across the return channel, and a 3.3 K ohm, 1/4 watt resistor in series with each switch.

NOTE

If using more than one switch, the first active condition (switch closed) must be latched. Any subsequent closed switch will indicate a short circuit fault condition.

Make no connection to "+ Supply" terminal.

Input — Deluge and Pre-Action

The initiating device circuit(s) for use with the deluge and pre-action system configuration must use Class A wiring or be wired within 20 feet and in conduit from the EDIO.

Two-Wire Smoke Detectors

The EDIO supports 2-wire devices from Kidde-Fenwal and Apollo. Figure 3-31 shows the wiring for Apollo detectors connected to EDIO Channel 1 through terminals 1 and 2.

Figure 3-32 shows the typical wiring for Kidde-Fenwal detectors connected to the EDIO through Channel 1 using terminals 1 and 2.

The EDIO supports either brand of detection products, however, mixing brands is not supported on either a single channel or module.



IMPORTANT

No more than 15 devices can be connected per channel.

Unsupervised Output

Connect external system wiring to the appropriate terminals on the terminal block. See Figure 3-33.

No connection should be made to "+ Supply" terminal.

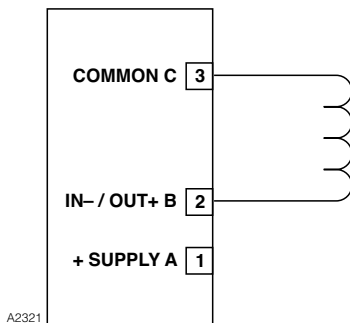

NOTE: SHUNT/FLYBACK DIODES DO NOT NEED TO BE INSTALLED ON THE FIELD DEVICE. CIRCUIT PROTECTION IS PROVIDED WITHIN THE EDIO MODULE.

Figure 3-33—Unsupervised Output Configuration

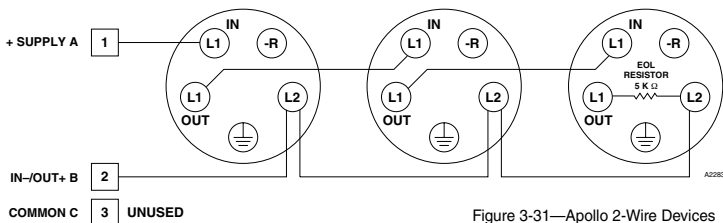

Figure 3-31—Apollo 2-Wire Devices

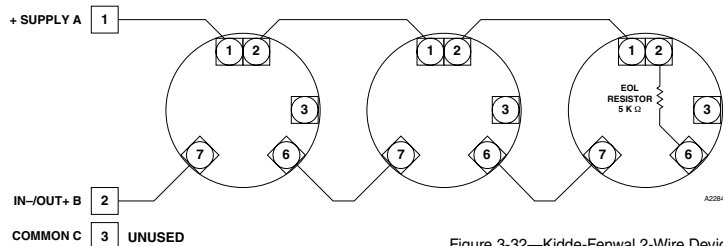

Figure 3-32—Kidde-Fenwal 2-Wire Devices

**Supervised Output—
Notification Supervised for Open & Short
Circuits**

Connect external system wiring to the appropriate terminals on the terminal block. For Class B wiring, refer to Figure 3-34.

For Class A wiring, refer to Figure 3-35. Note that two channels are used for one output circuit.

The output of the EDIO module supervises the notification circuit by reversing the polarity of the monitoring circuit. Polarity must be observed when connecting the notification device. It is essential to utilize a notification device approved for fire alarm notification. These devices are polarized and would not require the use of an external diode for the supervision of the circuit. Wire one or more notification devices to the output, with a 10 K ohm, 1/4 watt EOL resistor in parallel across the last device.

No connection should be made to “+ Supply” terminal.

Each output channel is individually activated for response pattern:

- supervisory
- continuous output
- 60 beats per minute
- 20 beats per minute
- temporal
- timed
- trouble.

**Supervised Output—
Agent Release (Solenoid Circuit)**

Connect external system wiring to the appropriate terminals on the terminal block. For Class B wiring, refer to Figure 3-36.

For Class A wiring, refer to Figure 3-37. Note that two channels are used for one output circuit. Trouble indication is provided for any open wire and the output can still be activated with a single open wire.

No connection should be made to “+ Supply” terminal.

The output of the EDIO module supervises the releasing circuit via the coil of the releasing solenoid. It is essential to utilize a releasing device approved for use with this output

module. This type of output does not require the use of EOL resistors or diodes to supervise the circuit.

The output can be configured for latching, continuous, supervisory, trouble or timed response.

To ensure adequate operating voltage for the output device, the maximum wiring length from the power source to the output device must not exceed the values shown in Table 3-10 for automatic release applications. (For solenoids,

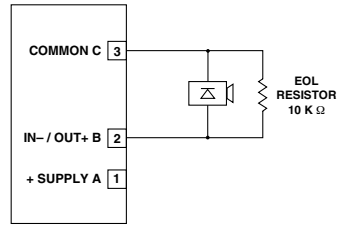

Figure 3-34—Supervised Output Configuration (Notification)— Class B

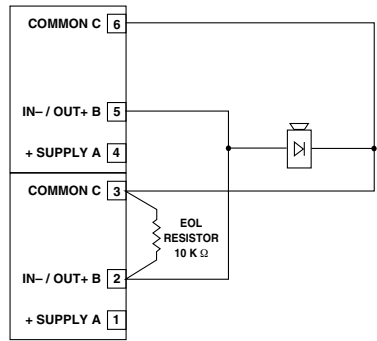
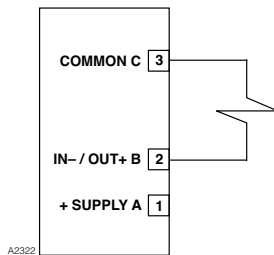

Figure 3-35—Supervised Output Configuration (Notification)— Class A



NOTE: SHUNT/FLYBACK DIODES DO NOT NEED TO BE INSTALLED ON THE FIELD DEVICE. CIRCUIT PROTECTION IS PROVIDED WITHIN THE EDIO MODULE.

Figure 3-36—Supervised Output Configuration (Agent Release)

this wire length includes both the wiring from the power supply to the EDIO module and the wiring from the module to the solenoid.)

Supervised Output for Deluge and Pre-action

To ensure proper operating voltage, the input voltage to the EDIO must be in the range from 21 to 30 vdc and the maximum wiring length must not exceed the values shown in Table 3-11 for deluge and pre-action applications. Per FM Approval requirements, the secondary power must provide capacity for a 90 hour minimum standby operation followed by a minimum of 10 minutes of releasing and alarm operation. **The initiating device circuit(s) for use with the deluge and pre-action system configuration must use Class A wiring or be wired in conduit within 20 feet from the EDIO.**

NOTE

In EQP systems with EQP2120PS(-B) Power Supplies, the secondary power is customer supplied and must be accepted by the Authority Having Jurisdiction (AHJ).

CONFIGURATION

Setting EDIO Network Address

One unique network address must be assigned to each EDIO module. The address is set by the 8 switch DIP assembly on the EDIO module.

When using the switches located on the EDIO module, the address is binary coded and is the sum of all switches placed in the “closed” position.

Each discrete point of an EDIO module has a tag number and a descriptor for unique identification. A tag number must include

zone designation, which will be shown on the controller’s display when the point is in alarm.

Det-Tronics S³ Safety System Software is used for device configuration. The following shows the minimum software/firmware releases:

Controller Firmware		S ³
Revision	Version	Version
B	4.28	3.1.0.0

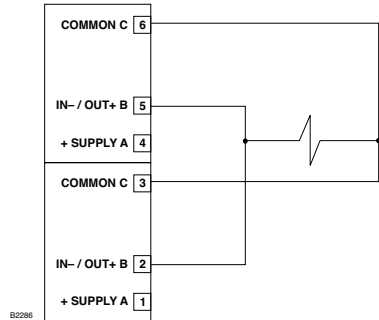

NOTE: SHUNT/FLYBACK DIODES DO NOT NEED TO BE INSTALLED ON THE FIELD DEVICE. CIRCUIT PROTECTION IS PROVIDED WITHIN THE EDIO MODULE.

Figure 3-37—Supervised Output Configuration (Agent Release)— Class A Wiring

Table 3-10—Maximum Wire Length for Releasing Applications

Device	Maximum Wire Length in Feet			
	12 AWG	14 AWG	16 AWG	18 AWG
890181*	150	100	60	
895630*	150	100	60	
897494*	190	120	75	
570537**	3000	1900	1200	750

*Fenwal Solenoid
**Ansul Solenoid

Table 3-11—Maximum Wiring Length for FM Approved Solenoids for Deluge and Pre-Action Applications

Solenoids			Maximum Wire Length in Feet (Meters)			
FM Solenoid Group	Manufacturer	Model	12 AWG	14 AWG	16 AWG	18 AWG
B	ASCO	T8210A107	183 (56)	115 (35)	72 (22)	46 (14)
D	ASCO	8210G207	314 (96)	198 (60)	124 (38)	78 (24)
E	Skinner	73218BN4UNLVC111C2	331(101)	208 (63)	131 (40)	82 (25)
F	Skinner	73212BN4TNLVC322C2	130 (40)	82 (25)	51 (16)	32 (10)
G	Skinner	71395SN2ENJ1NOH111C2	331 (101)	208 (63)	131 (40)	82 (25)
H	Viking	11601	180 (55)	110 (34)	70 (21)	45 (14)

8 CHANNEL DISCRETE INPUT/OUTPUT (DCIO) MODULE INSTALLATION

NOTE

It is recommended to maintain a minimum of 4 inches clearance between the module and other equipment to provide adequate room for wiring and ventilation.

The following paragraphs describe how to properly install and configure the 8 Channel DCIO Module.

MOUNTING

The DCIO must be properly installed in a suitable enclosure that is rated for the location. The enclosure must provide space to install and wire the DCIO module and must also provide for ground wire termination. Access into the enclosure is gained by using a special tool to open the enclosure. The enclosure should be rated for the temperature range of the location plus the temperature rise of all equipment installed inside the enclosure. The enclosure must be rated for electrical equipment that is going to be installed.

The DCIO can be panel or DIN rail mounted.

WIRING

All electrical connections are made to the field wiring connectors furnished with the module. See Figure 3-38 for terminal identification.

Power Connector, Terminals 1 to 6 24 Vdc Power Input

Power connections to the DCIO depend upon the total current consumption of all the channels in the device. Each output-configured channel can consume up to 2 amperes. Total output current should be limited to 10 amperes. Connect the power supply to terminals 1 and 2 or to terminals 4 and 5. Power wire shielding

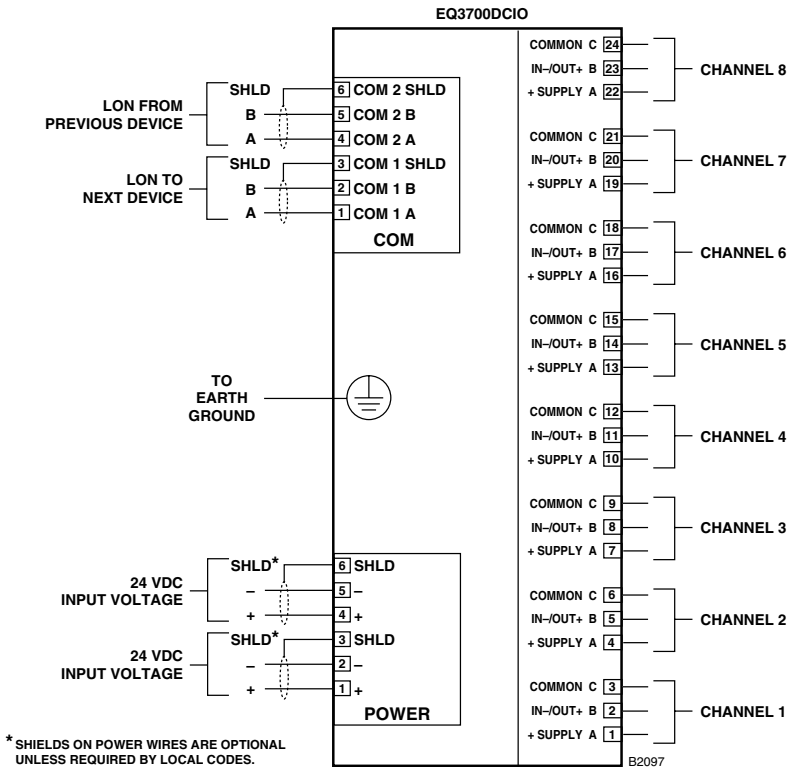

Figure 3-38—DCIO Module Wiring Terminal Configuration

should be connected to terminals 3 and 6.

- 1 — +
- 2 — -
- 3 — Shield*
- 4 — +
- 5 — -
- 6 — Shield*

*Shields on power wires are optional unless required by local codes.

Connect the module power supply to terminals 1 and 2. If additional terminals are required for powering other devices, these devices should be connected to terminals 4 and 5. Shields are to be connected to terminals 3 and 6.

**COM Connector, Terminals 1 to 6
LON Terminals**

Be sure to observe polarity when wiring the LON.

- 1 — "A" side of signaling circuit for COM 1
- 2 — "B" side of signaling circuit for COM 1
- 4 — "A" side of signaling circuit for COM 2
- 5 — "B" side of signaling circuit for COM 2
- 3 & 6 — shield connections.

**Channel Connectors, Terminals 1 to 24
Terminals A, B & C
Channels 1 to 8 Input / Output Terminals**

Refer to individual wiring configurations for terminal descriptions. Only channel 1 is shown in each diagram. The information is typical for channels 2-8.

Unsupervised Input

Connect external system wiring to the appropriate terminals. See Figure 3-39.

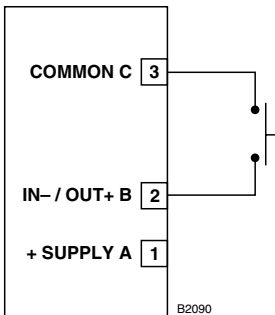

Figure 3-39—Unsupervised Input Configuration

Input to the DCIO consists of one or more normally open or normally closed switches.

NOTE

An EOL resistor is not required.

NOTE

No connection should be made to the "+ Supply" terminal.

**Supervised Input (IDC) Open Circuit
Supervision Class B**

Connect external system wiring to the appropriate terminals on the DCIO terminal block. See Figure 3-40.

The input to the DCIO module consists of one or more normally open switches, with a 10K ohm, 1/4 watt EOL resistor in parallel across the last switch.

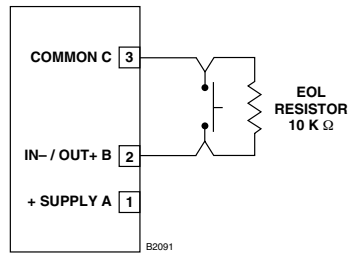

Figure 3-40—Supervised Input Configuration

NOTE

No connection should be made to the "+ Supply" terminal.

**Supervised Input (IDCSC) Open
and Short Circuit Supervision
(Three state – open, switch closure, and
short) Class B**

Connect external wiring to the appropriate terminals on the DCIO terminal block. See Figure 3-41. Indication of short circuit fault is provided.

The input to the DCIO module consists of a normally open switch, with a 10 K ohm, 1/4 watt EOL resistor in parallel across the switch, and a 3.3 K ohm, 1/4 watt resistor in series with the switch.

NOTE

No connection should be made to the “+ Supply” terminal. For correct operation, only one input switch can be used per channel.

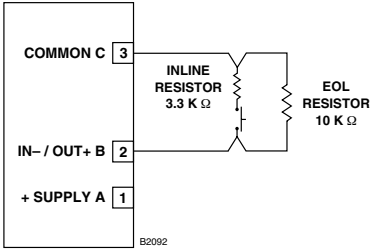

Figure 3-41—Supervised Input Configuration (Opens and Shorts)

Supervised Output Notification (Horns and Strobes) Supervised Outputs for Open & Short Circuits Class B

Connect external wiring to the appropriate terminals on the DCIO terminal block. See Figure 3-42.

The output of the DCIO module supervises the notification circuit by reversing the polarity of the monitoring circuit.

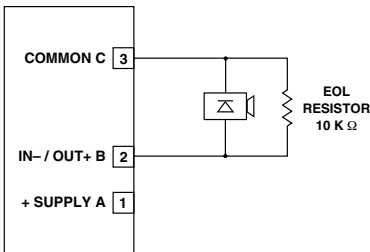

Figure 3-42—Supervised Output Configuration (Notification)

NOTE

Polarity MUST be observed when connecting the notification device.

It is critical to use a notification device approved for fire alarm notification. These devices are polarized and do not require the use of an external diode for the supervision of the circuit. Wire one or more notification devices to the output, with a 10 K ohm, 1/4 watt EOL resistor in parallel across the last device.

NOTE

No connection should be made to the “+ Supply” terminal.

Each output channel is individually activated for response pattern:

- continuous output
- 60 beats per minute
- 120 beats per minute
- temporal
- supervisory
- timed
- trouble.

Supervised Output for Automatic Release Supervised Output for Open Circuits

Connect external wiring to the appropriate terminals on the DCIO terminal block. See Figure 3-43.

Wire one or more releasing devices to the module output.

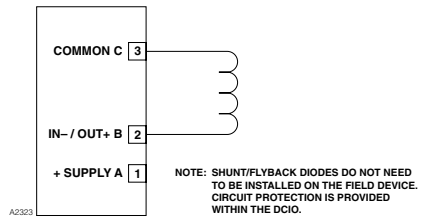

Figure 3-43—Supervised Output Configuration (Automatic Release)

NOTE

Make no connection to the “+ Supply” terminal.

The output of the DCIO module supervises the releasing circuit via the coil of the releasing solenoid. It is essential to use a releasing device approved for use with this output module.

NOTE

This type of output does not require the use of EOL resistors or diodes to supervise the circuit.

The output can be configured for latching, continuous or timed response.

To ensure proper operating voltage, the maximum wiring length from the power source to the DCIO module must not exceed

the values shown in Table 3-12 for automatic release applications.

Table 3-12—Maximum Wire Length for Automatic Releasing Applications

Device	Maximum Wire Length in Feet			
	12 AWG	14 AWG	16 AWG	18 AWG
890181*	150	100	60	
895630*	150	100	60	
897494*	190	120	75	
570537**	3000	1900	1200	750

*Fenwal Solenoid

**Ansul Solenoid

NOTE

For solenoids, this wire length includes both the wiring from the power supply to the DCIO module and the wiring from the module to the solenoid.

Supervised Output for Deluge and Pre-action

Connect external wiring to the appropriate terminals on the DCIO terminal block. See Figure 3-43.

The output of the DCIO module supervises the releasing circuit via the coil of the releasing solenoid. It is essential to use a releasing device approved for use with this output module.

NOTE

This type of output does not require the use of EOL resistors or diodes to supervise the circuit.

NOTE

For new or retrofit installations, any manufacturer's non-water based agent release valves can be wired into the outputs of the ARM or DCIO modules as long as the devices utilize 24 vdc and do not exceed 2 amperes current draw.

Table 3-13—Maximum Wire Length for FM Approved Solenoids for Deluge and Pre-Action Applications

Solenoids			Maximum Wire Length in Feet (Meters)			
FM Solenoid Group	Manufacturer	Model	12 AWG	14 AWG	16 AWG	18 AWG
B	ASCO	T8210A107	183 (56)	115 (35)	72 (22)	46 (14)
D	ASCO	8210G207	314 (96)	198 (60)	124 (38)	78 (24)
E	Skinner	73218BN4UNLVNOC111C2	331(101)	208 (63)	131 (40)	82 (25)
F	Skinner	73212BN4TNLVNOC322C2	130 (40)	82 (25)	51 (16)	32 (10)
G	Skinner	71395SN2ENJ1NOH111C2	331 (101)	208 (63)	131 (40)	82 (25)
H	Viking	11601	180 (55)	110 (34)	70 (21)	45 (14)

NOTE

For FM system approval listing, pre-action and deluge applications require that only FM approved deluge valves can be wired into the ARM or DCIO modules. Table 3-13 lists the supported solenoid groups. Remember that the valves must utilize 24 vdc and must not exceed 2 amperes current draw.

The output can be configured for latching, continuous or timed response.

To ensure proper operating voltage, the input voltage to the DCIO must be in the range from 21 to 30 vdc and the maximum wiring length must not exceed the values shown in Table 3-13 for deluge and pre-action applications. Per FM Approval requirements, the secondary power must provide capacity for a 90 hour minimum standby operation followed by a minimum of 10 minutes of releasing and alarm operation. **For initiating device circuit(s) for use with the deluge and pre-action system configuration, an Enhanced Discrete Input/Output Module (EDIO) must be used.**

NOTE

In EQP systems with EQP2120PS(-B) Power Supplies, the secondary power is customer supplied and must be accepted by the Authority Having Jurisdiction (AHJ).

Unsupervised Output Ancillary Applications (Unrelated to Fire Detection/Protection)

Connect external wiring to the appropriate terminals on the DCIO terminal block. See Figure 3-44.

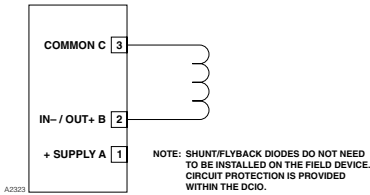

Figure 3-44—Unsupervised Output Configuration

NOTE

No connection should be made to the "+ Supply" terminal.

CONFIGURATION

Setting DCIO Network Address

One unique network address must be assigned to each DCIO module. The address is set by the 8 switch DIP assembly on the DCIO module. The address is binary coded and is the sum of all switches placed in the "closed" position.

Each discrete point of a DCIO module has a tag number and a descriptor for unique identification. A tag number must include zone designation, which will be shown on the controller's display when the point is in alarm.

Det-Tronics S³ Safety System Software is used for device configuration. The following shows the minimum software/firmware releases:

Controller Firmware		S ³
Revision	Version	Version
A	1.03	2.0.2.0

8 CHANNEL RELAY MODULE INSTALLATION

The following paragraphs describe how to properly install and configure the 8 Channel Relay Module.

MOUNTING

The Relay Module must be properly installed in a suitable enclosure that is rated for the location. The enclosure must provide space to install and wire the relay module and must also provide for ground wire termination. Access into the enclosure is gained by using a special tool to open the enclosure. The enclosure should be rated for the temperature range of the location plus the temperature rise of all equipment installed inside the enclosure. The enclosure must be rated for electrical equipment that is going to be installed. The device can be panel or DIN rail mounted.

NOTE

It is recommended to maintain a minimum of 4 inches clearance between the module and other equipment to provide adequate room for wiring and ventilation.

WIRING

All electrical connections are made to the field wiring connectors furnished with the module. See Figure 3-45 for terminal identification.

Power Connector, Terminals 1 to 6 24 Vdc Power Input

- 1 — +
- 2 — -
- 3 — Shield*
- 4 — +
- 5 — -
- 6 — Shield*

*Shields on power wires are optional unless required by local codes.

Connect the module power supply to terminals 1 and 2. If additional terminals are required for powering other devices, these devices should be connected to terminals 4 and 5. Shields are to be connected to terminals 3 and 6.

COM Connector, Terminals 1 to 6 LON Terminals

Be sure to observe polarity when wiring the LON.

- 1 — "A" side of signaling circuit for COM 2
- 2 — "B" side of signaling circuit for COM 2
- 3 — "A" side of signaling circuit for COM 1
- 4 — "B" side of signaling circuit for COM 1
- 5 — "A" side of signaling circuit for COM 2
- 6 — "B" side of signaling circuit for COM 1
- 3 & 6 — shield connections.

Channel Connectors, Terminals 1 to 24 Unsupervised Output Ancillary Applications (Unrelated to Fire Detection/Protection)

Connect external wiring to the appropriate terminals on the relay module terminal block. See Figure 3-45.

CONFIGURATION

Setting Relay Module Network Address

One unique network address must be assigned to each relay module. The address is set by the 8 switch DIP assembly on the relay module. The address is binary coded and is the sum of all switches placed in the "closed" position.

Each discrete point of a relay module has a tag number and a descriptor for unique identification.

Det-Tronics S³ Safety System Software is used for device configuration. The following shows the minimum software/firmware releases:

Controller Firmware		S ³
Revision	Version	Version
A	2.01	2.8.0.0

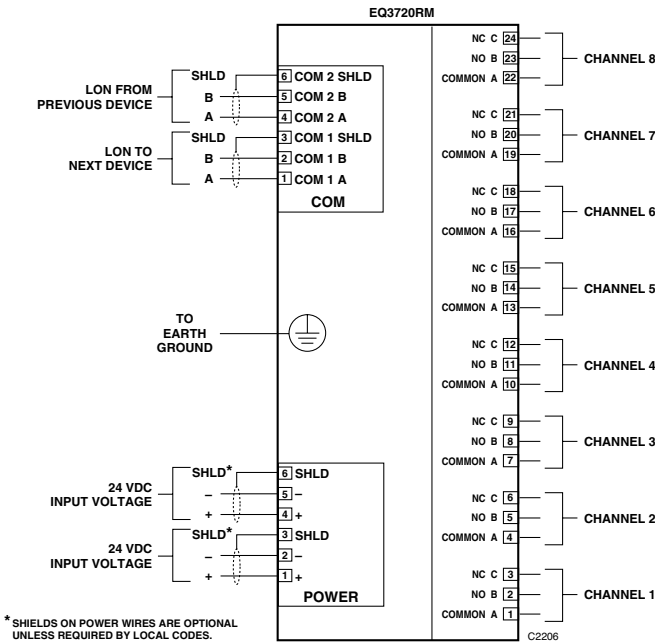

NOTE: RELAY CONTACTS SHOWN IN REST (DE-ENERGIZED) STATE.

Figure 3-45— Relay Module Wiring Terminal Configuration

ANALOG INPUT MODULE INSTALLATION

MOUNTING

The Analog Input Module must be properly installed in a suitable enclosure that is rated for the location. The enclosure must provide space to install and wire the device and must also provide for ground wire termination. Access into the enclosure must be gained by using a special tool to open the enclosure. The enclosure should be rated for the temperature range of the location plus the temperature rise of all equipment installed inside the enclosure. The enclosure must be rated for electrical equipment that is going to be installed.

NOTE

It is recommended to maintain a minimum of 4 inches clearance between the module and other equipment to provide adequate room for wiring and ventilation.

WIRING

All electrical connections are made to the field wiring connectors furnished with the module. (Connectors accept up to 12 AWG wire.) Refer to Figure 3-46 for identification of module wiring terminals.

Power Connector — Terminals 1 to 6 24 Vdc Power Input

- 1 — +
- 2 — -
- 3 — Shield*
- 4 — +
- 5 — -
- 6 — Shield*

*Shields on power wires are optional unless required by local codes.

Connect the module power supply to terminals 1 and 2. If additional terminals are required for powering other devices, these devices should be connected to terminals 4 and 5. Shields are to be connected to terminals 3 and 6.

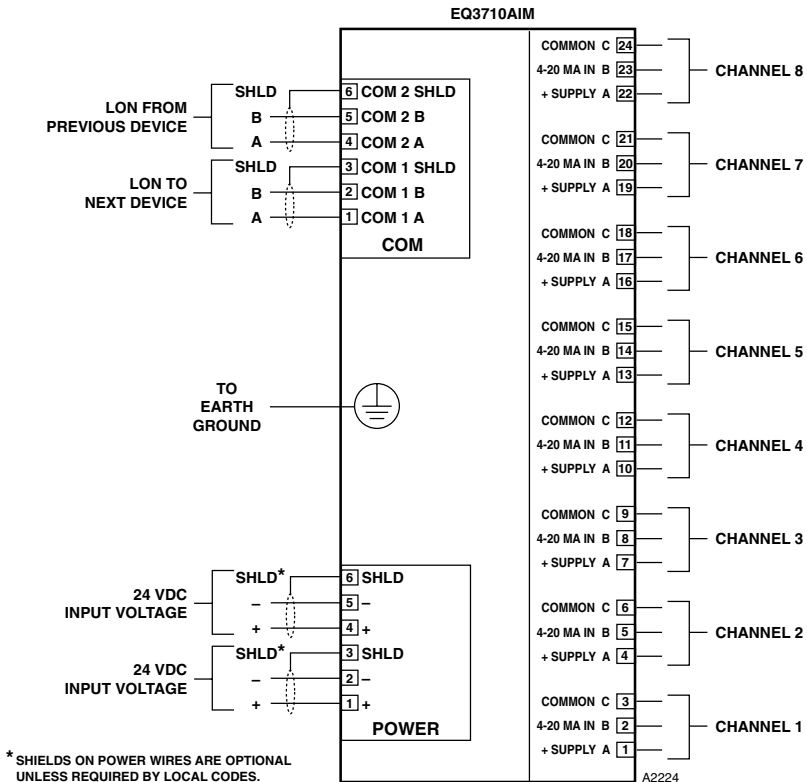

Figure 3-46—Analog Input Module Wiring Terminal Configuration

COM Connector — Terminals 1 to 6 LON Terminals

Be sure to observe polarity when wiring the LON.

- 1 — "A" side of signaling circuit for COM 1
- 2 — "B" side of signaling circuit for COM 1
- 4 — "A" side of signaling circuit for COM 2
- 5 — "B" side of signaling circuit for COM 2
- 3 & 6 — shield connections (shields required).

Channel Connectors — Terminals 1 to 24 4-20 mA Input Devices

Connect external wiring to the appropriate terminals on the analog input module terminal block. See Figure 3-47 for an example of a 2-wire input. See Figure 3-48 for a 2-wire input with HART interface module. See Figure 3-49 for a 3-wire input, where the transmitter must source a 4-20 mA signal. See Figure 3-50 for a 3-wire input with HART interface module.

Only channel 1 is shown in each diagram. The information is typical for channels 2-8.

Analog Input Module Channels used as NFPA 72 Approved 4-20 mA Flame Detector Input

Configure the High Alarm setpoint at 19 mA via the S³ configuration screen, and use the High Alarm to trigger the Fire Alarm in S³ logic. The AIM sends an exception message for the High Alarm so there is no delay in transmitting the Fire Alarm.

Fault indications and other status information must be decoded in logic from the analog process variable. A five second delay should be used to avoid indicating an incorrect status condition while the analog value is changing between two values. See Table 3-14.

Table 3-14—

Analog Values (in mA) for Fault and Status Indications when the AIM is Used as a 4-20 mA Flame Detector Input

Status	X3301/2	X5200	X9800	X2200
Fault	0-3.5	0-3.5	0-3.5	0-3.5
IR Pre-Alarm		7.0-9.0		
UV Alarm		11.0-12.99		
IR Alarm		13.0-14.99		
Pre-Alarm		15.0-16.99	15.0-16.99	15.0-16.99

CONFIGURATION

Setting Analog Input Module Network Address

One unique network address must be assigned to each analog input module. The address is set by the 8 switch DIP assembly on the analog input module.

When using the switches located on the analog input module, the address is binary coded and is the sum of all switches placed in the "closed" position.

Each point of an analog input module has a tag number and a descriptor for unique identification. A tag number must include zone designation, which will be shown on the controller's display when the point is in alarm.

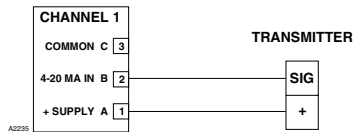

Figure 3-47—Two-Wire Transmitter — Non-Isolated 4 to 20 mA Current Output (Sourcing)

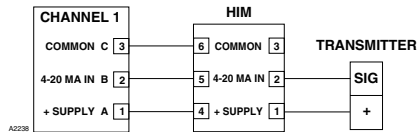

Figure 3-48—Two-Wire Transmitter with HART Interface Module — Non-Isolated 4 to 20 mA Current Output (Sourcing)

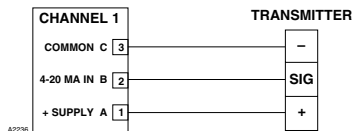

Figure 3-49—Three-Wire Transmitter — Non-Isolated 4 to 20 mA Current Output (Sourcing)

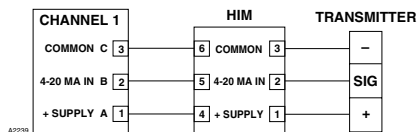

Figure 3-50—Three-Wire Transmitter with HART Interface Module — Non-Isolated 4 to 20 mA Current Output (Sourcing)

Det-Tronics S³ Safety System Software is used for device configuration. The following tables show the minimum software/firmware releases:

For Gas Applications

Controller Firmware*		AIM		S ³
Rev.	Version	Rev.	Version	Version
B	3.06	B	1.02	2.9.1.1

*for part number 007606-002

For Flame Applications

Controller Firmware*		AIM		S ³
Rev.	Version	Rev.	Version	Version
C	5.52	D	1.07	4.0.0.0

*for part number 008983-001

GAS DETECTOR LOCATION AND INSTALLATION

Gas detection devices must be properly located to provide maximum protection. Determining the proper number of devices and placement varies depending on the specific requirements of the area of protection.

The following should be considered when locating a gas detection device:

1. Gas type. If it is lighter than air (acetylene, hydrogen, methane, etc.), place the sensor above the potential source. Place the sensor close to the floor for gases that are heavier than air (benzene, butane, butylene, propane, hexane, pentane, etc.) or for vapors resulting from flammable liquid spills.

NOTE

Air currents can cause a gas that is heavier than air to rise. Also, if the gas is hotter than ambient air, it could also rise.

2. How rapidly will the gas diffuse into the air? Select a location for the sensor as close as possible to the anticipated source of a gas leak.
3. Ventilation characteristics. Air movement will cause gas to accumulate more heavily in one area than another. The devices should be placed in areas where the most concentrated accumulation of gas is anticipated.
4. Devices should be pointed down to prevent the buildup of moisture or contaminants on the filter.
5. Devices must be accessible for testing and calibration.

NOTE

The use of the Sensor Separation Kit will be required in some installations.

ENVIRONMENTS AND SUBSTANCES THAT AFFECT GAS DETECTOR PERFORMANCE

Catalytic sensors should be located where they are safe from potential sources of contamination that can cause a decrease in the sensitivity of the device including:

- A. Substances that can clog the pores of the flame arrestor and reduce the gas diffusion rate to the sensor including:

Dirt and oil, corrosive substances such as Cl₂ (Chlorine) or HCl, paint overspray, or residue from cleaning solutions that can clog the flame arrestor.

NOTE

A dust cover should be installed to protect the flame arrestor whenever these conditions exist.

- B. Substances that cover or tie up the active sites on the catalytic surface of the active sensing element such as volatile metal organics, gases, or vapors of hydrides, and volatile compounds containing phosphorous, boron, silicone, etc.

Examples:

RTV silicone sealants
Silicone oils and greases
Tetraethyl lead
Phosphine
Diborane
Silane
Trimethyl chlorosilane
Hydrogen fluoride
Boron trifluoride
Phosphate esters

- C. Materials that remove the catalytic metals from the active element of the sensor. Some substances react with the catalytic metal forming a volatile compound that can erode the metal from the surface of the sensor's active element.

Halogens and compounds containing halogen are materials of this nature and others include:

Examples:

Chlorine
Bromine
Iodine
Hydrogen Chloride, Bromide or Iodide
Organic halides:
Trichloroethylene
Dichlorobenzene
Vinyl chloride
Freons
Halon 1301
(Bromotrifluoromethane).

NOTE

Brief exposure to these materials can temporarily increase sensor sensitivity due to the surface of the active element being etched. Prolonged exposure continues this process until the sensitivity of the sensor is degraded, resulting in shortened sensor life.

- D. Exposure to high concentrations of combustible gases for extended periods of time can stress the sensing element and seriously affect its performance.

The degree of damage to the sensor is determined by a combination of contaminant type, contaminant concentration in the atmosphere, and the length of time the sensor is exposed.

NOTE

If a sensor has been exposed to a contaminant or a high level of combustible gas, it should be calibrated at the time of exposure. An additional calibration a few days later should be performed to determine whether a significant shift in sensitivity has occurred. If necessary, sensor should be replaced.

NOTE

A combination of accessories such as rain shields and dust covers is not recommended and can result in slow response to a gas leak.

EQ22XXDCU DIGITAL COMMUNICATION UNIT USED WITH DET-TRONICS H2S/O2 SENSORS OR OTHER TWO-WIRE 4-20 MA DEVICES

Determine the best mounting locations for the detectors. Whenever practical, detectors should be placed where they are easily accessible for calibration.

WARNING!

Do not apply power to the system with the cover removed unless the area has been verified to be free of combustible gases or vapors.

The DCU utilizes the following:

1. A terminal wiring board mounted at the bottom of the junction box.
2. A communication module mounted above the terminal wiring board using the standoffs provided. See Figure 3-51.

Assembly and Wiring Procedure

Attach the sensor to the DCU enclosure. Do not over-tighten. If a sensor separation kit is being used, attach the sensor to the separation kit junction box and wire the device as described in the “Sensor Separation” section.

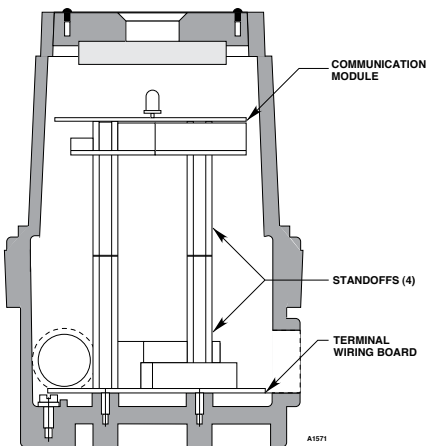

Figure 3-51—Printed Circuit Boards in Universal DCU

CAUTION!

The sensor threads can be coated with an appropriate grease to ease installation. Also lubricate the cover threads. (See “Ordering Information” for part number of recommended lubricant.)

Connect the external wiring to the appropriate terminals on the DCU terminal wiring board. Refer to Figure 3-52 for terminal identification. See Figure 3-53 for an example of a Det-Tronics electrochemical sensor connected to a DCU.

Attach the communication module to the standoffs as shown in Figure 3-51. Connect the ribbon cable from the terminal wiring board to the communication module.

Set the address for the device. Refer to “Setting Device Network Addresses” for complete information regarding the switch setting procedure.

Check the wiring to ensure proper connections, then pour the conduit seals and allow them to dry (if conduit is being used).

NOTE

Before placing the cover back on the enclosure following completion of assembly and wiring, inspect the enclosure O-ring to be sure that it is in good condition and properly installed. Lubricate the O-ring and the threads of the cover with a thin coat of an appropriate grease to ease installation. Refer to the “Ordering Information” section for the part number of the recommended grease (available from Detector Electronics). If the installation uses catalytic type combustible gas sensors, it is imperative that lubricants containing silicone not be used, since they will cause irreversible damage to the sensor. Place the cover on the enclosure. Tighten only until snug. Do not over tighten.

Sensor Separation for DCU with H2S and O2 Sensors

Since the transmitter for the electrochemical sensor is already mounted within the sensor housing, simply mount the entire sensor assembly to the sensor separation kit junction

box and wire it to terminals 2 and 4 inside the DCU, the same as a regular (without sensor separation) installation. Connect the shield to the ground terminal in the DCU junction box.

Refer to Table 3-15 for separation distance limitations for H2S and O2 sensors

EQ22XXDCU DIGITAL COMMUNICATION UNIT USED WITH POINTWATCH/ DUCTWATCH

Determine the best mounting location for the detector. Whenever practical, detectors should be placed where they are easily accessible for calibration.



WARNING!

Do not apply power to the system with the cover removed unless the area has been verified to be free of combustible gases and vapors.

The DCU utilizes the following:

1. A terminal wiring board mounted at the bottom of the junction box.
2. A communication module mounted above the terminal wiring board using the standoffs provided. See Figure 3-51.

Assembly and Wiring Procedure

Attach the PointWatch/DuctWatch to the DCU enclosure. Do not over-tighten. If a sensor separation kit is being used, attach the sensor to the separation kit junction box and wire the device as described in the "Sensor Separation" section.

Refer to the PointWatch instruction manual (form number 95-8440) or the DuctWatch instruction manual (form number 95-8573) for complete installation and application information.

Refer to Figure 3-54 when wiring a PointWatch IR gas detector and a DCU. The wiring code for PointWatch is:

- Red = + (24 vdc)
- Black = - (common)
- White = 4 to 20 ma signal
- Yellow = Calibration input
- Green = Chassis ground

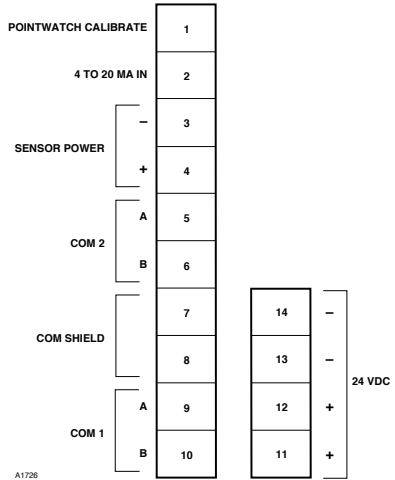

Figure 3-52—Wiring Configuration for DCU

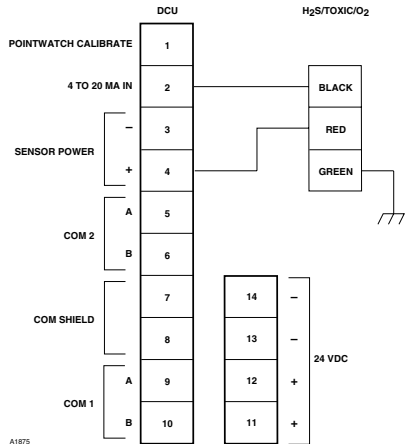

Figure 3-53—Electrochemical Sensor Connected to DCU

Table 3-15
Maximum Separation Distances —
Electrochemical Sensor to DCU

Wire Size (AWG)	Maximum Wiring Distance	
	Feet	Meters
18	5700	1750
16	9000	2800

T0020A

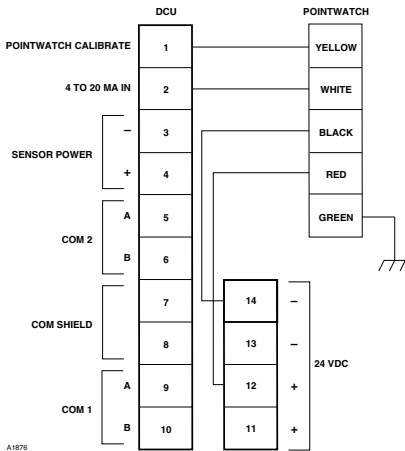

Figure 3-54—PointWatch/DuctWatch Connected to DCU

Set the address for the device. Refer to "Setting Device Network Addresses" for complete information regarding the switch setting procedure.

Sensor Separation for DCU with PointWatch

Shielded four wire cable is recommended for connecting the detector junction box to the DCU. Cable with a foil shield is recommended. The shield of the cable should be open at the detector junction box and connected to earth ground at the DCU junction box.

NOTE

To ensure proper operation, it is essential to maintain a minimum of 18 vdc (including ripple) at the PointWatch detector.

EQ22XDCUEX DIGITAL COMMUNICATION UNIT (USED WITH DET-TRONICS COMBUSTIBLE GAS SENSORS)

Mounting

Determine the best mounting location for the device. Whenever practical, the device should be placed where it can easily be reached for calibration.

IMPORTANT!

Always orient the junction box with the sensor pointing down.

WARNING!

Do not apply power to the system with the cover removed unless the area has been verified to be free of combustible gases or vapors.

Wiring

1. Remove the cover from the DCUEX.

CAUTION!

ALWAYS discharge static from tools and hands by touching the device body before touching the communication module or transmitter board.

2. Loosen the screws on the communication module and remove it from the transmitter board standoffs.
3. Disconnect the ribbon cable from the communication module.
4. Remove the standoffs and detach the transmitter board from the terminal wiring board. Do not disconnect any wiring.
5. Connect all external wiring to the terminal wiring board. (See Figure 3-55.)

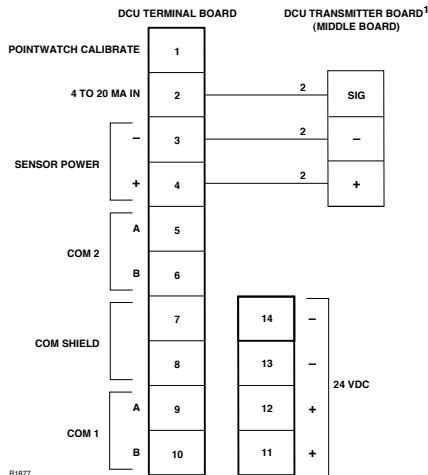

NOTES: 1 Catalytic Combustible Gas Sensor Plugs into Connector Pins on the Middle Board inside the Junction Box.
2 Connections Wired at the Factory.

Figure 3-55—DCU Transmitter Board Connected to Terminal Wiring Board

NOTE

Make sure the ribbon cable is connected to the terminal wiring board.

6. Attach the sensor to the device enclosure. DO NOT overtighten.

NOTE

If a sensor separation kit is being used, attach the sensor to the separation kit junction box. (See Sensor Separation with DCUEX below.)

7. Plug the sensor into P2 on the transmitter board.
8. Mount the transmitter board to the terminal wiring board and attach with the standoffs.

NOTE

Be sure to note the correct orientation of the transmitter board. If the transmitter board is rotated 180° from proper orientation, the device will not operate correctly — a LON communication fault will result. See Figure 3-56.

9. Plug the ribbon cable into the communication module and re-attach it to the transmitter board.
10. Set the device network address. (See “Setting Device Network Addresses” in this section.)
11. Inspect the junction box O-ring to be sure that it is in good condition. Lubricate the O-ring and the threads of the junction box cover with a thin coat of silicone-free grease (available from Det-Tronics).
12. Replace the device cover.

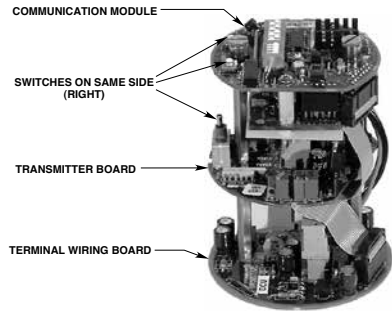

CORRECT ORIENTATION OF TRANSMITTER BOARD

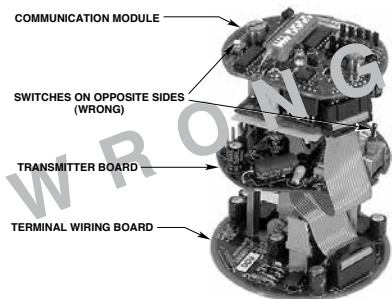

INCORRECT ORIENTATION OF TRANSMITTER BOARD

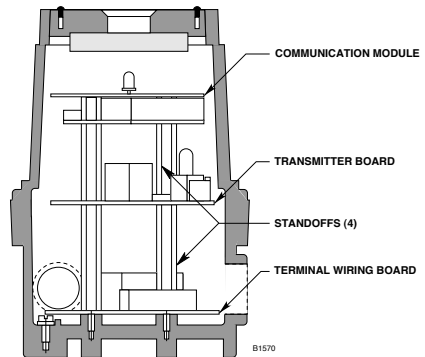

Figure 3-56—Printed Circuit Boards in Combustible Gas DCU

Sensor Separation with DCUEX

If the installation requires mounting the sensor in a different location than the DCUEX, observe the following guidelines.

There are two (2) methods that can be used to separate the sensor from the DCUEX:

Preferred Method

1. Disassemble the DCUEX and remove the transmitter board. (Refer to "Wiring" for disassembly procedure.) Do not re-assemble at this time.

2. Mount the transmitter board inside the sensor separation junction box (remove the existing board).

NOTE

This assembly can be separated from the DCUEX by up to 1000 feet using three conductor 18 AWG shielded cable. (Regardless of separation distance, operating voltage at the transmitter must be at least 18 vdc for proper device operation.) (See Figure 3-57.)

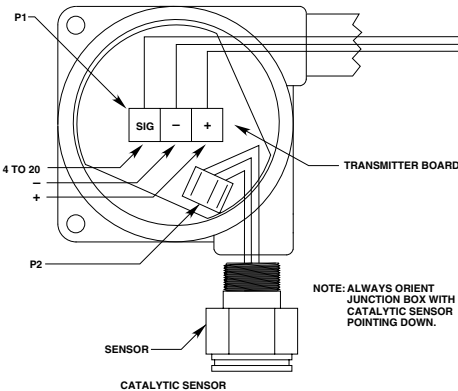
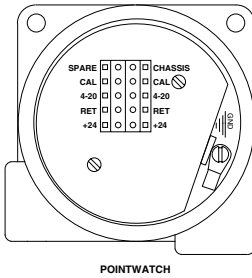
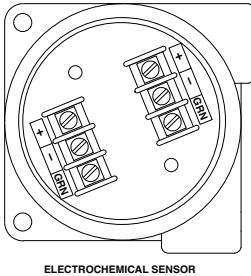

Table 3-16—Maximum Separation Distances — Combustible Gas Sensor to DCU (Alternate Method)

Wire Size	Maximum Separation Distance	
	Feet	Meters
18 AWG (1.0 mm ²)*	40	12
16 AWG (1.5 mm ²)*	60	18
14 AWG (2.5 mm ²)*	100	30
12 AWG (4.0 mm ²)*	150	45

*Approximate Metric Equivalent.

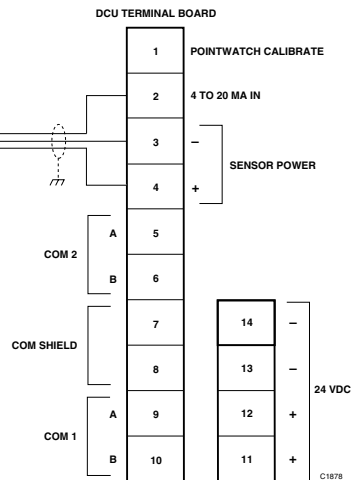

Figure 3-57—Sensor Separation Kits

3. Mount the sensor to the separation junction box. DO NOT overtighten. Plug the sensor into P2 on the transmitter board.
4. Use a three conductor 18 AWG shielded cable to connect P1 on the transmitter board to terminals 2, 3 and 4 on the DCU terminal board (See Figure 3-57). Connect the shield to the ground terminal in the DCUEX junction box.
5. Connect all external wiring to the terminal wiring board inside the DCU (if not already completed). Re-assemble the DCUEX as described in the "Wiring" section. When completed, it should look similar to the DCU as shown in Figure 3-51.
6. Inspect the O-ring on the DCU and separation junction box to be sure that they are in good condition. Lubricate the O-ring and the threads of the junction box cover with a thin coat of silicone-free grease (available from Det-Tronics).
7. Replace the cover on the DCU and separation junction box.

Alternate Method

If the transmitter board must be mounted separate from the sensor (high temperature applications, etc.), separate the sensor only, leaving the transmitter PC board inside the DCUEX enclosure. When using this installation option, see Table 3-16 for maximum wiring distances.

Mount the sensor directly to the separation kit junction box. Use three conductor shielded cable for the connection between the terminal block in the separation kit junction box and P2 on the DCUEX transmitter board. A plug with screw terminals is provided for connecting the cable to P2 on the transmitter board. Observe the wiring color code. Connect the shield to the ground terminal in the DCUEX junction box.

EQ25XXARM SERIES AGENT RELEASE MODULE

Mounting

The device should be securely mounted to a vibration free surface. (See "Specifications" in this manual for device dimensions.)

Wiring

To ensure proper operating voltage for the output device, the maximum wiring length from power source to device must not exceed the values shown in Table 3-17 for automatic release applications or Table 3-18 for deluge and pre-action applications.

NOTE

For solenoids, this wire length includes both the wiring from power supply to device, and the wiring from device to solenoid.

See Figure 3-58 for identification of wiring terminals.

Terminals 1 to 4 — Output terminals

Connect a single solenoid between terminals 1 and 4. Connect dual solenoids between terminals 1 and 2, and between terminals 3 and 4.

NOTE

For testing purposes, a load resistor of 1200 to 1500 ohms @ 1 watt can be placed across terminals 1 and 4.



CAUTION!

DO NOT intermix different types of initiators in release circuit.

Table 3-17—Maximum Wire Length for Automatic Releasing Applications

Device	Maximum Wire Length in Feet			
	12 AWG	14 AWG	16 AWG	18 AWG
890181*	150	100	60	
895630*	150	100	60	
897494*	190	120	75	
570537**	3000	1900	1200	750

*Fenwal Solenoid

**Ansul Solenoid

Table 3-18—Maximum Wire Length for FM Approved Solenoids for Deluge and Pre-Action Applications

Solenoids			Maximum Wire Length in Feet (Meters)			
FM Solenoid Group	Manufacturer	Model	12 AWG	14 AWG	16 AWG	18 AWG
B	ASCO	T8210A107	183 (56)	115 (35)	72 (22)	46 (14)
D	ASCO	8210G207	314 (96)	198 (60)	124 (38)	78 (24)
E	Skinner	73218BN4UNLVNOC111C2	331(101)	208 (63)	131 (40)	82 (25)
F	Skinner	73212BN4TNLVNOC322C2	130 (40)	82 (25)	51 (16)	32 (10)
G	Skinner	71395SN2ENJ1NOH111C2	331 (101)	208 (63)	131 (40)	82 (25)
H	Viking	11601	180 (55)	110 (34)	70 (21)	45 (14)

Terminals 5 to 10 —LON signaling circuit terminals

NOTE

Be sure to observe polarity when wiring the LON.

5 — “A” side of signaling circuit for COM 2

6 — “B” side of signaling circuit for COM 2

7 and 8 — shield connections

9 — “A” side of signaling circuit for COM 1

10 — “B” side of signaling circuit for COM 1

Terminals 11 to 14 —24 vdc power input

Connect module power supply to terminals 12 and 13.

NOTE

If an auxiliary output supply is used for powering solenoids, it should be connected to terminals 11 and 14.

Supervised Output for Deluge and Pre-action

Connect external wiring to the appropriate terminals on the terminal block. See Figure 3-58. Wire one or more releasing devices to the module output.

The output of the Agent Release Module supervises the releasing circuit via the coil of the releasing solenoid. It is essential to use a releasing device approved for use with this output module.

NOTE

This type of output does not require the use of EOL resistors or diodes to supervise the circuit.

The output can be configured for latching, continuous or timed response.

To ensure proper operating voltage, the input voltage to the release module must be in the range from 21 to 30 vdc and the maximum wiring length must not exceed the values shown in Table 3-18 for deluge and pre-action applications. Per FM Approval requirements, the secondary power must provide capacity for a 90 hour minimum standby operation followed by a minimum of 10 minutes of releasing and alarm operation. **The initiating device**

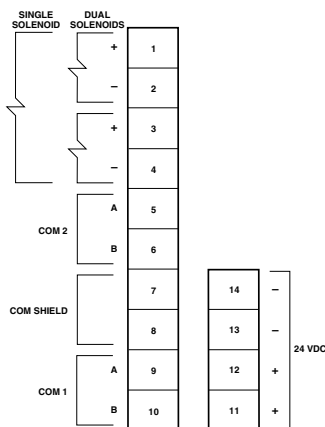

NOTE:
 TERMINALS 12 AND 13 ARE FOR MODULE POWER SUPPLY.
 TERMINALS 11 AND 14 ARE FOR AUXILIARY OUTPUT POWER SUPPLY.
 JUMPERS JP2 AND JP3 MUST BE REMOVED IF AN AUXILIARY POWER SUPPLY IS USED.

Figure 3-58—Wiring Configuration for Agent Release Module

circuit(s) for use with the deluge and pre-action system configuration must be wired within 20 feet and in conduit from an IDC or DCIO. In addition, power for the device(s) must be per NFPA 72 Class A wiring techniques.

NOTE

In EQP systems with EQP2120PS(-B) Power Supplies, the secondary power is customer supplied and must be accepted by the Authority Having Jurisdiction (AHJ).

Jumpers

Terminals 13 and 14 are connected by jumper JP2 and terminals 11 and 12 are connected by jumper JP3. These two jumpers (JP2 and JP3) must be cut if an auxiliary output power supply is being used. (See Figure 3-59 for jumper locations.)

When an explosive initiator is being used, jumper JP1 must be cut. If a solenoid is used, the jumper must remain in.

Address Setting

Set the device network address. (See "Setting Device Network Addresses" in this section.)

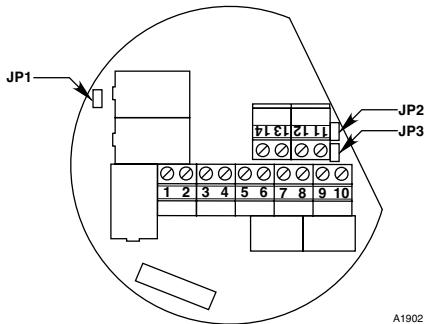

Figure 3-59—

Agent Release Module Wiring Terminals and Jumpers

Table 3-19—Maximum Wiring Length from Nominal 24 VDC Power Source to Signaling Device

Maximum Wire Length in Feet (Meters)			
	12 AWG (4 mm ²)*	14 AWG (2.5 mm ²)*	16 AWG (1.5 mm ²)*
One 2 Ampere Load	190 (58)	120 (37)	75 (23)
Two 2 Ampere Loads	95 (29)	60 (18)	35 (11)

* Approximate Metric Equivalent.

T0029A

EQ25XXSAM SERIES SIGNAL AUDIBLE MODULE

Mounting

The device should be securely mounted to a vibration free surface. (See "Specifications" in this manual for device dimensions.)

Wiring



IMPORTANT!

To ensure adequate operating voltage for the signaling device, the maximum wiring length from the power source to the output device must not exceed the values shown in Table 3-19. (This wire length includes both the wiring from the power supply to the signal audible module and the wiring from the module to the signaling device.)

See Figure 3-60 for identification of wiring terminals.

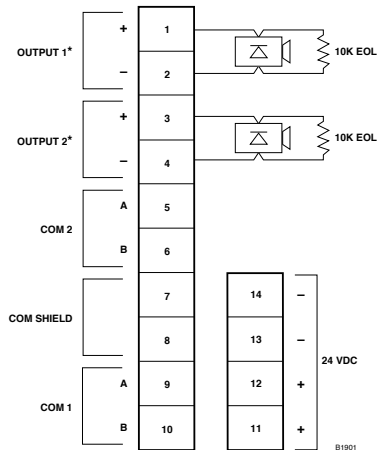

* POLARITY SHOWN IS FOR MONITORING CONDITION, POLARITY IS REVERSED WHEN ACTIVATED.

NOTE: TERMINALS 12 AND 13 ARE FOR MODULE POWER SUPPLY. TERMINALS 11 AND 14 ARE FOR AUXILIARY OUTPUT POWER SUPPLY. JUMPERS JP1 AND JP2 MUST BE REMOVED IF AN AUXILIARY POWER SUPPLY IS USED.

Figure 3-60—

Wiring Configuration for Signal Audible Module

Terminals 1 to 4 — Output terminals

Connect the first output device between terminals 1 and 2, and the second between terminals 3 and 4.

NOTE

Polarity shown in Figure 3-60 is for monitoring condition; polarity is reversed when activated.

Each circuit must have a 10 kohm EOL resistor.

Terminals 5 to 10 — LON signaling circuit terminals

Be sure to observe polarity when wiring the LON.

5 — “A” side of signaling circuit for COM 2

6 — “B” side of signaling circuit for COM 2

7 and 8 — shield connections

9 — “A” side of signaling circuit for COM 1

10 — “B” side of signaling circuit for COM 1

Terminals 11 to 14 — 24 vdc power input

Connect the module power supply to terminals 12 and 13. If an auxiliary output supply is used for powering signaling devices, it should be connected to terminals 11 and 14.

Jumpers

Terminals 13 and 14 are connected by jumper JP2 and terminals 11 and 12 are connected by jumper JP1. These two jumpers (JP1 and JP2) must be cut if an auxiliary output power supply is being used. (See Figure 3-61) for jumper locations.

Address Setting

Set device network address. (See “Setting Device Network Addresses” in this section.)

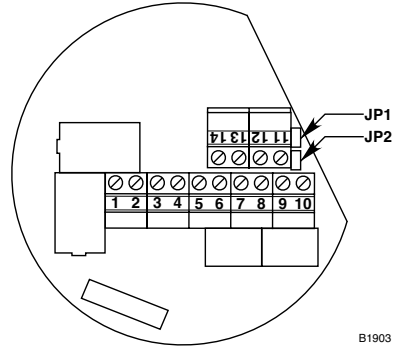

Figure 3-61—
Signal Audible Module Wiring Terminals and Jumpers

SYSTEM CONFIGURATION

SETTING DEVICE NETWORK ADDRESSES

Overview of Network Addresses

Each device on the LON must be assigned a unique address. Addresses 1 to 4 are reserved for the controller. Addresses 5 to 250 are reserved for field devices. Valid addresses for field devices are from 5 to 250.

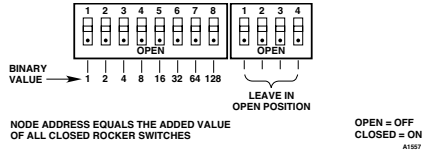

Figure 3-62—Field Device Address Switches for ARM, SAM, DCU and IDC

IMPORTANT

If the address is set to zero or an address above 250, the communication module will ignore the switch setting.

Duplicated addresses are not automatically detected. Modules given the same address will use the number given and report to the controller using that address. A "Rogue Device" message will be displayed when two LON devices have duplicate addresses assigned to them. The status word will show the latest update, which could be from any of the reporting modules using that address.

Setting Field Device Addresses

Selection of the node address for field devices is done by setting rocker switches on an 8 switch "DIP Switch" within each device's housing.

NOTE

Only the first eight of the 12 switches are used for selecting the device address.

The address number is binary encoded with each switch having a specific binary value with switch 1 being the LSB (Least Significant Bit). (See Figure 3-62) The device's LON address is equal to the added value of all closed rocker switches. All "Open" switches are ignored.

NOTE

The address switches in the DCIO module and relay module appear slightly different than those in other devices. Refer to Figure 3-63.

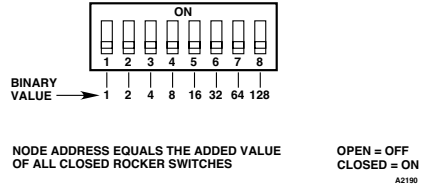

Figure 3-63—Address Switch for DCIO and Relay Module

Example: for node No. 5, close rocker switches 1 and 3 (binary values 1 + 4); for node No. 25, close rocker switches 1, 4 and 5 (binary values 1 + 8 + 16).

NOTE

The field device sets the LON address only when power is applied to the device. Therefore, it is important to set the switches before applying power. If an address is ever changed, system power must be cycled before the new address will take effect.

After setting address switches, record the address number and device type on the "Address Identification Chart" provided with this manual. Post the chart in a convenient location near the Controller for future reference.

TYPICAL APPLICATIONS

Figure 3-64 is a simplified drawing of a typical EQP system. This system includes an EQP Controller, DCIO and various LON field devices.

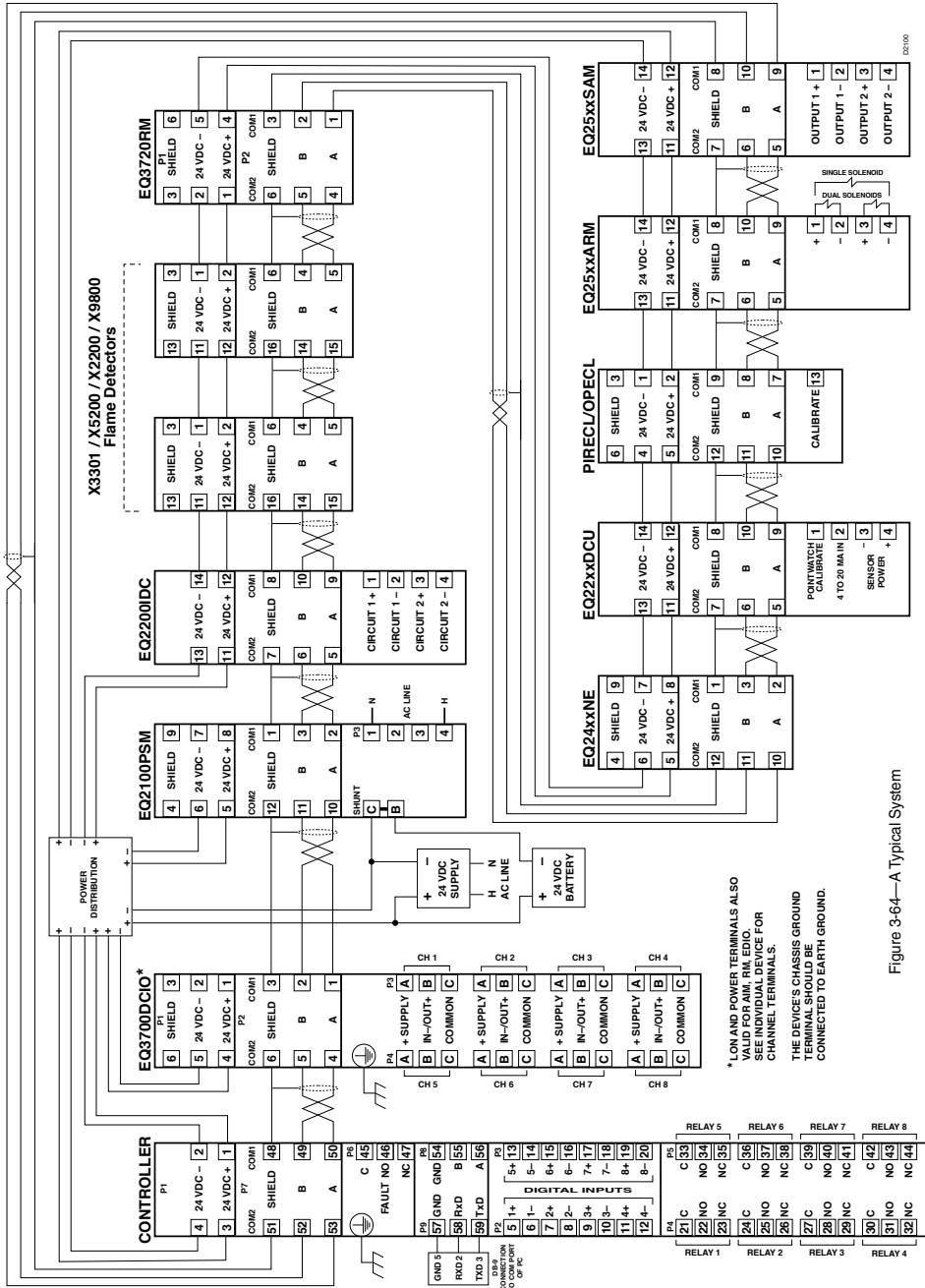

Figure 3-64—A Typical System

* LON AND POWER TERMINALS ALSO VALID FOR AMI, RIM EDIO, AND RIM EDIO. SEE PAGE FOR CHANNEL TERMINALS.
 THE DEVICE'S CHASSIS GROUND TERMINAL SHOULD BE CONNECTED TO EARTH GROUND.

Section 4 Operation

SYSTEM CONTROLLER

PUSHBUTTONS

The Controller has seven pushbuttons (located on the front panel) for user interface. These pushbuttons allow the operator to interact with the Controller to respond to alarms and system status conditions, access system status reports, and configure Controller time and date settings.

The following paragraphs describe the function of each pushbutton. Refer to Figure 4-1 for Controller pushbutton locations.

Cancel cancels the selected command, and returns the menu to the last option list displayed.

Enter chooses the menu item selected, and advances the menu to the next options list. (See “Controller Menu Options” in this section for additional information.)

NOTE

Pressing Enter while alarms are actively scrolling returns the display to the Main Menu.

Next allows the operator to scroll through options listed within each menu. Each time the NEXT pushbutton is pushed, the current options list indexes up one list item. (See “Controller Menu Options” in this section for additional information)

Previous allows the operator to scroll through options listed within each menu. Each time the PREVIOUS pushbutton is pushed, the current options list indexes down one list item. (See “Controller Menu Options” in this section for additional information)

Reset resets all controller latched outputs that are no longer active.

Acknowledge silences the internal beeper.

Silence turns on the Silence LED and sets Silence status in user logic.

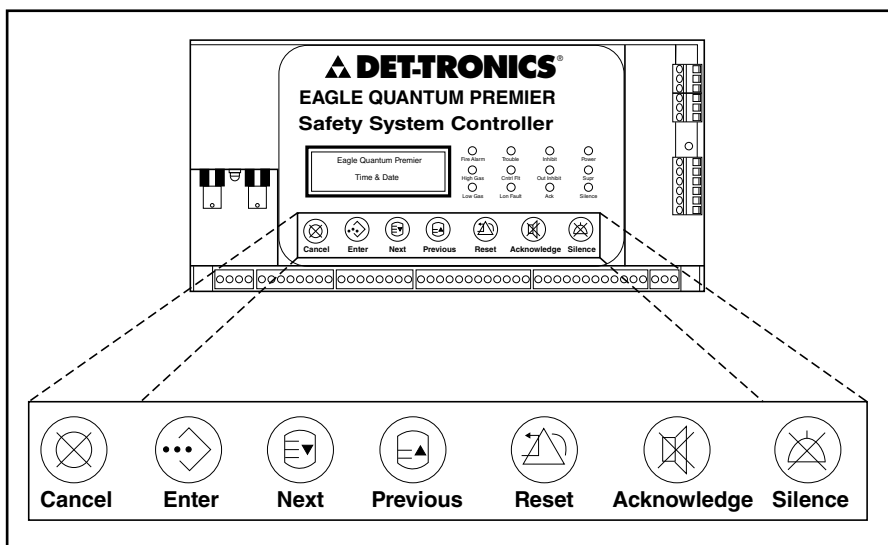

Figure 4-1—EQP Controller Pushbutton Locations

CONTROLLER STATUS INDICATORS

System status is visually displayed on the Controller in two ways — through the use of a Text Display (see Figure 4-2), and through colored LED's (see Table 4-1). The following paragraphs describe these indicators and the function of each.

TEXT DISPLAY

The Controller uses a text based display to show current system status, active Alarms and Faults.

When an alarm or trouble condition occurs, the display scrolls a detailed message of the condition, including tag number, condition (alarm, trouble, supervisory etc.) and time/date. If multiple alarms or trouble conditions exist, the display scrolls through all active status conditions until they go inactive and are reset using the controller pushbutton.

CONTROLLER MENU OPTIONS

The Controller is designed to display system status and device related information. The following paragraphs describe how to move around within the controller's menu structure to access this information and perform minor system settings (see Figure 4-3).

NOTE

During normal operation (no alarms or trouble conditions occurring), the display scrolls current system time and date.

Main Menu displays a list of options to access information types available for display through the Controller. This list also includes access to options used to set system date and time, and diagnostics options.

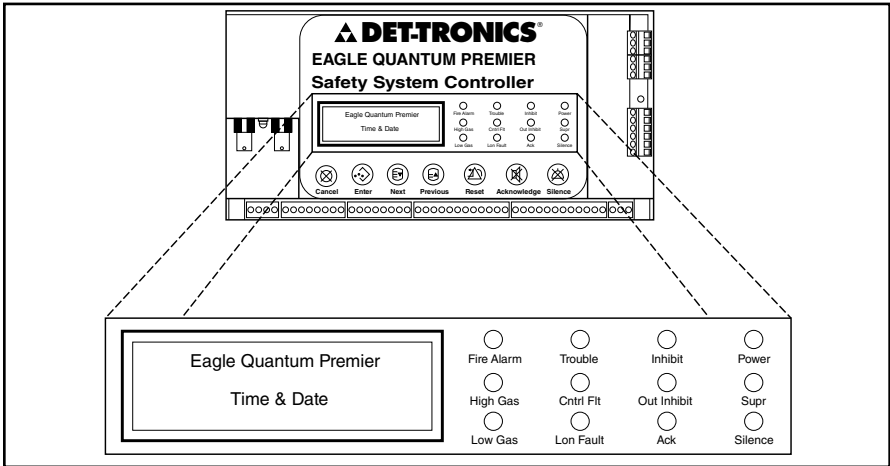

Figure 4-2—EQP Controller Message Display and System Status Indicator Location

Table 4-1—EQP Controller LED System Status Indicators

LED	Function	Status
Green	Power	On when power is applied.
Red	Fire Alarm	On (latched) when any fire alarm is active (Fire detected).
Amber	Trouble	On (latched) when a fault is detected in the system. (Indicates "Trouble" relay state.)
Amber	Ack	On when the Acknowledge button is pressed.
Amber	Silence	On when Silence pushbutton is pressed.
Amber	Inhibit	On when any input channel is inhibited.
Amber	Out Inhibit	On when any output is inhibited.
Red	High Gas	On (latched) when any gas detector is at or above the High gas alarm value.
Red	Low Gas	On (latched) when any gas detector is at or above the Low gas alarm value.
Amber	Supr	On (latched) when any Supervisory input is active.
Amber	LON Fault	On when a LON fault is detected (open or short).
Amber	Cntrl Fault	On when a processor fault occurs.

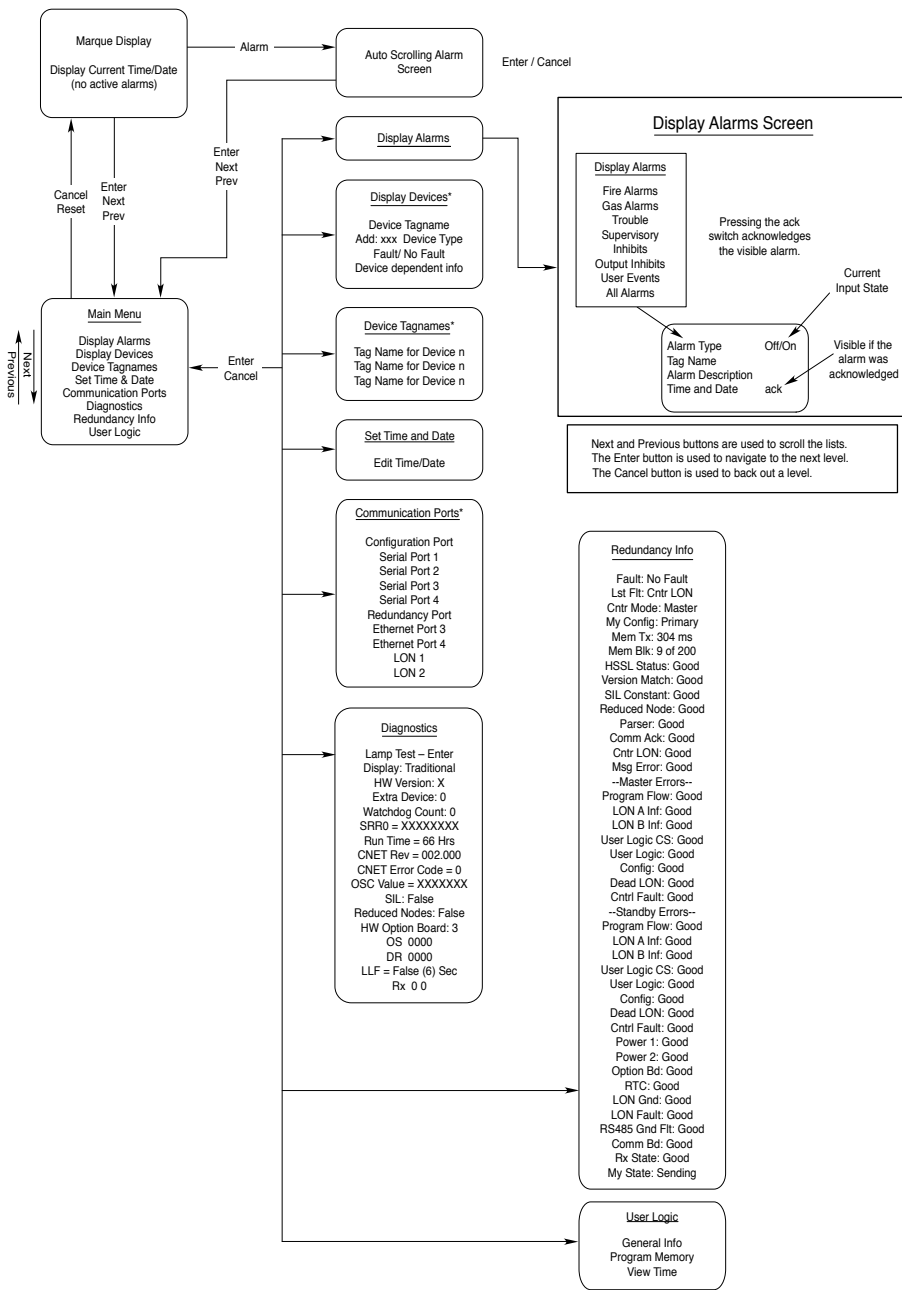

Figure 4-3—EQP Controller Message Display Menu Outline



Moving within the Main Menu is done by using the NEXT or PREVIOUS pushbuttons located on the controller's front panel. The menu options will scroll upward (NEXT Pushbutton) or downward (Previous Pushbutton) while the Main Menu name remains stationary. When the desired menu option is selected by the ">" indicator, the ENTER pushbutton is pressed to advance the menu display to the desired information set.

NOTE

Pressing the CANCEL pushbutton from within any sub-menu returns the display to the Main Menu. The display will also return to the Main Menu if left unattended for a period of 20 minutes. If an alarm or trouble condition is present after 20 minutes, the display will change to the existing Alarm or Trouble message.

DISPLAY ALARMS displays a list of existing Alarms and Trouble conditions. Moving within this menu is done by using the NEXT or PREVIOUS pushbuttons.



NOTE

Multiple alarm information can be viewed by pressing the NEXT or PREVIOUS pushbuttons. Pressing CANCEL will return the menu to the DISPLAY ALARMS menu.

DISPLAY DEVICES displays device information on all devices on the LON loop. Device tag name, type, and node address are displayed.

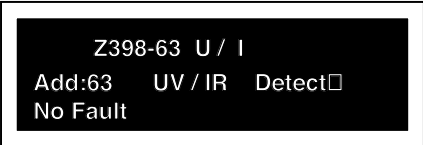

Pressing the NEXT or PREVIOUS pushbuttons allows cycling through devices. Pressing the CANCEL pushbutton will return the display to the Main Menu.

DEVICE TAG NAMES displays device tag name information for all devices on the LON loop.



Pressing the NEXT or PREVIOUS pushbutton allows cycling through devices. Pressing the CANCEL pushbutton will return the display to the Main Menu.

SET TIME AND DATE provides access to configuration controls for system clock and date settings.



NOTE

When the Set Time and Date menu opens, the current hour will flash.

To move within this menu, press the ENTER pushbutton until the desired property is flashing. To set the desired property value, press the NEXT Pushbutton to increase or PREVIOUS Pushbutton to decrease the value. When the desired value is displayed, press the ENTER pushbutton. This will advance the menu to the next property and it will flash. When all desired properties have been entered, press the ENTER pushbutton until the message "Press ENTER to Save" is displayed. When the ENTER pushbutton is pressed, the settings are saved and the menu changes back to the MAIN MENU.

SERIAL PORTS displays port information on all available ports.



```
Serial Ports
Configuration Port
Serial Port 1
Serial Port 2
```

Pressing the NEXT or PREVIOUS pushbutton allows cycling through ports. Pressing the CANCEL pushbutton will return the display to the Main Menu.

DIAGNOSTICS displays information for factory field service.



```
Diagnostics
Lamp Test -Enter-
Display: Traditional
HW Version: 2
```

REDUNDANCY INFO displays the current status of all redundancy related faults. It can be used to monitor the health of the master and standby controllers. It can also be used for diagnostic purposes.

Redundancy faults originate from three general areas:

- Self detected internal failures of the master controller
- Inter-controller communications
- A failure in the standby controller.

Any redundancy fault is annunciated by the master controller, and the redundancy fault code of the highest priority fault is displayed. The controller also provides a diagnostic menu for more detailed information on the source of a redundancy problem. All redundancy related faults must be cleared to insure proper redundancy operation.

Fault

Displays the current redundancy fault.

Lst Flt

Displays the last redundancy fault that occurred.

Cntr Mode

Indicates whether the controller is in master or standby mode.

My Config

Indicates whether the controller is the primary or secondary controller.

Redun Mem

Displays how long it takes to transfer the local and global memory between controllers.

HSSL Status

An error is generated when a problem is detected on the high-speed communication link between controllers. This fault is annunciated when the standby controller is offline.

Version Match

To ensure proper redundant operation, the firmware versions of redundant controllers must match. This error is set when a mismatch is detected. Consult the factory for firmware upgrades.

SIL Rating

To ensure proper redundant operation, the SIL rating of redundant controllers must match. An error is indicated if a SIL controller is paired with a non-SIL rated controller. Consult the factory for details.

Parser

As the master controller configures a standby controller, configuration information is extracted from non-volatile memory and checked for errors.

Comm Ack

Critical information is exchanged between controllers on the HSSL using acknowledged messages. The master sends data packets that contain an embedded CRC and a transaction number. The standby validates the message by calculating and comparing the CRC values. If the CRC is correct the standby saves the data and returns an acknowledge message with the transaction number. If an acknowledge message with the proper transaction number is not received by the master within the allotted time the message is resent. When all retries are used the acknowledge error is indicted and acknowledged communication is terminated.

Lon Comm

Redundant controllers exchange information across the LON network. This is primarily done to prevent both controllers from becoming the master in the event that the HSSL fails. The fault is announced when a controller fails to receive any information from the other controller.

Msg Error

If the standby controller receives a message from the master that has the correct CRC but invalid data an error message is returned. This master will indicate the error with this fault.

Program Flow

Program flow checking ensures that essential functions execute in the correct sequence. If any functions don't execute properly, or execute in the wrong order, the program flow error is set and control is transferred to the standby controller.

LON A/B Inf

Controllers utilize neuron co-processors to interface with the field device network. If an error is detected in the operation of the co-processor, a LON interface fault is announced.

User Logic CS

Controllers continually conduct a checksum test of the user logic program to ensure that the data remains unchanged. A user checksum fault is announced if the result is incorrect.

App CS

When the controller firmware is generated a checksum of the program is calculated and saved in memory. Each controller is continually conducting a checksum test of the program to ensure that the data remains unchanged. The application checksum fault is announced if the result is incorrect.

User Logic

Many checks are conducted while the controller interprets and executes the user program. The user logic error is generated if invalid or out of range data is detected.

Config

This fault is announced when a controller has not been configured or the configuration information has been corrupted.

Table 4-2—EQP Controller Alarm Tone Patterns

Priority	Controller Tone	Tone Pattern
1	Fire Alarm	Temporal
2	Supervisory	Supervisory
3	Trouble	Trouble
4	High Gas	Gas
5	Low Gas	Gas
6	Normal	Off

Power 1

Displays the power 1 status on the standby controller.

Power 2

Displays the power 2 status on the standby controller.

Option Bd

Indicates whether there is a fault on the ControlNet or Ethernet DLR option board of the standby controller.

CONTROLLER AUDIBLE ALARM

The Controller features an internal audible alarm for local system status notification (see Table 4-2 and Figure 4-4). When the system is operating in the normal mode (no Alarm or Fault conditions occurring), the alarm is silent (off). If an event (any alarm or trouble condition) occurs, the alarm will remain active until it is acknowledged by pressing the Acknowledge pushbutton or reset by pressing the Reset pushbutton on the Controller front panel.

NOTE

If multiple alarms exist, "Acknowledging" will silence the audible alarms.

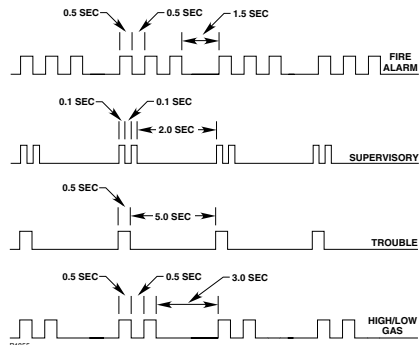

Figure 4-4—Tone Pattern for Controller Buzzer

Table 4-3—Status of ControlNet LED Indicators

A and B	Cause	Action
Off	No power	None or power up.
Steady red	Faulted unit	Cycle power. If fault persists, contact the factory.
Alternating red/green	Self-test	None
Alternating red/off	Incorrect node configuration	Check network address and other ControlNet configuration parameters.
A or B	Cause	Action
Off	Channel disabled	Program network for redundant media, if required.
Steady green	Normal operation	None
Flashing green/off	Temporary errors	None; unit will self-correct.
	Listen only	Cycle power.
Flashing red/off	Media fault	Check media for broken cables, loose connectors, missing terminators, etc.
	No other nodes present on network	Add other nodes to the network.
Flashing red/green	Incorrect network configuration	Cycle power or reset unit. If fault persists, contact the factory.

CONTROLNET STATUS INDICATORS (Optional)

The optional ControlNet status indicator LEDs function as follows: (see Table 4-3)

Steady - The indicator is on continuously in the defined state.

Alternating - The two indicators alternate between the two defined states at the same time (applies to both indicators viewed together). The two indicators are always in opposite states, out of phase.

Flashing - The indicator alternates between the two defined states (applies to each indicator viewed independent of the other). If both indicators are flashing, they must flash together, in phase.

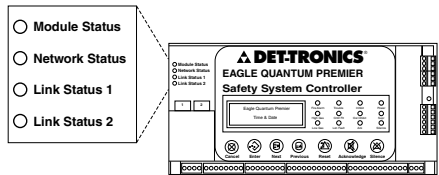

Figure 4-5—Location of Ethernet DLR Status LEDs

ETHERNET DLR STATUS INDICATORS (Optional)

The Ethernet DLR has 4 status indicators: Module Status, Network Status, Link Status 1 and Link Status 2. See Figure 4-5 for location. The status indicator LEDs function as defined in Tables 4-4 through 4-6. A test sequence is performed on the Network Status and Module Status LEDs during startup.

Table 4-4—Ethernet DLR Module Status LED

LED State	Description
Off	No power.
Green	Controlled by a Scanner in Run state.
Green, flashing	Not configured, or Scanner in idle state.
Red	Major fault (EXCEPTION state, FATAL error, etc.)
Red, flashing	Recoverable fault(s)

Table 4-5—Ethernet DLR Network Status LED

LED State	Description
Off	No power or no IP address.
Green	Online, one or more connections established (CIP Class 1 or 3).
Green, flashing	Online, no connections established.
Red	Duplicate IP address, FATAL error.
Red, flashing	One or More connections timed out (CIP Class 1 or 3).

SEQUENCE OF EVENTS DURING A CONFIGURATION DATA DOWNLOAD

During a configuration download, the controller receives configuration data that is stored into flash memory. During the download process, the controller halts normal operation and resets a number of controller functions. Items affected and displayed during a configuration data download are listed in the following steps:

1. Halt the static logic and user logic programs.
2. Ignore field device LON communications. However, the controller continues to generate the LON heartbeat.
3. Silence the Controller's audible annunciator.
4. Initiate a Trouble condition that is signaled by the amber Trouble LED and relay.
5. Clear all Alarm and Fault events.
6. De-energize all 8 Controller relays.
7. Ignore Modbus communication.
8. ControlNet communication continues. Ethernet DLR communication goes through reset and configuration. DLR communication remains offline during this sequence (approximately 30 seconds).
9. Text display's first line indicates **** Program Mode ****
10. Text display's third line displays download status.
 - a) "Config Download" indicates the serial transfer into memory from the PC to the Controller.
 - b) "Erasing Flash" indicates that the controller is electronically erasing the contents of the Flash memory.

Table 4-6—Ethernet DLR Link Status 1 and Link Status 2 LEDs

LED State	Description
Off	No link, no activity.
Green	Link (100 Mbit/s) established.
Green, flickering	Activity (100 Mbit/s)
Yellow	Link (10 Mbit/s) established.
Yellow, flickering	Activity (10 Mbit/s)

- c) "Writing to Flash" indicates that configuration data stored in memory is being written down into Flash memory.
- d) "Flash Lock" indicates that the controller is locking the configuration data into the Flash memory.



CAUTION

The controller's configuration data will be corrupted if power is removed during a download. Contact the factory if this occurs.

11. Initialize the RS-485 and configuration serial ports with new parameters.
12. Initialize the ControlNet or Ethernet DLR option board with new parameters.
13. Enable static logic and user logic programs to operate. The first scan program is run first.
14. Accept field device LON communications.
15. Poll the device type variable from LON field devices.
16. Configure LON field devices.
17. Clear the Trouble condition.
18. Text display shows a normal operation marquee message.
 - a) Text display's first line indicates "Det-Tronics Eagle Quantum Premier".
 - b) Text display's third line displays time (24 hour format) and date (month/day/year).

NOTE

Depending on the condition of the LON devices, faults may persist for a number of minutes.

CONTROLLER REDUNDANCY

Pushbuttons

The pushbuttons are active on the master controller and inactive on the standby controller.

Controller Status Indicators

The status indicators are active on the master controller. All LEDs except the power LED are off and the trouble relay is in the no trouble state.

Controller Relay Operation

The controller relays are fully functional on the master controller and the standby controller.

Text Display

The text display on the master controller is fully functional as explained in the previous section. The text display on the standby controller reads ****Standby Mode****, Ready.

Controller Menu Options

The menu options are active on the master controller and inactive on the standby controller.

ControlNet or Ethernet DLR Status Indicators

The ControlNet or Ethernet DLR status indicators are active on the master and standby controller. See Table 4-3 for status of ControlNet LED indicators and Tables 4-4 through 4-6 for Ethernet DLR LED indicators.

Power-up Sequence

The power-up sequence for a redundant controller pair is as follows:

1. Make sure the LON and HSSL are connected correctly.
2. Apply power to both controllers.
3. Controllers go through their boot-up routine.
4. The controller that is connected with the primary end of the HSSL is identified as the primary controller and is assigned address 1.

5. The controller that is connected with the secondary end of the HSSL is assigned address 2.
6. If there are no faults present, the primary controller defaults to the master controller and the secondary controller defaults to the standby controller.
7. The master controller executes user logic and communicates with the connected LON devices.
8. The standby controller indicates that it is in standby mode and monitors the master controller.
9. The master and standby controller go through a synchronization process.
10. The power-up sequence is complete.

Synchronization

When a master controller detects a standby controller on the HSSL, it performs the following synchronization process:

1. Compare controller firmware versions and SIL rating. If they are not an exact match, the process stops and a fault is generated. Consult the factory for details.
2. Standby controller indicates the synchronization steps.
3. Compare the user application programs. If there is a mis-match, the master will configure the standby controller via the HSSL.
4. Initiate the data synchronization process.
5. Transfer the status of device inhibits and device removes.
6. Transfer the complete alarm list, including alarm history.
7. Transfer the real time clock (RTC) value.
8. Copy the local and global memory to the standby controller.
9. Synchronization is complete and the standby controller indicates "Ready".

Sequence of Events During a Configuration Download



WARNING

The system is inactive and not executing logic/alarm functions during a program download (in both single and redundant controller configurations).

When downloading a new configuration to the master controller, the following sequence is executed:

1. The S³ software must be connected to the master controller.
2. Alter the configuration and execute the download command from S³.
3. The master controller goes into 'Program' mode and passes mastership to the standby controller.
4. The updated configuration file is loaded into the controller.
5. The controllers are automatically forced to switch over.
6. The master controller puts the standby controller into 'Program' mode and downloads the configuration.
7. The controller indicates "Device Download Active" until the LON devices have been successfully updated.
8. The configuration download is now complete.

Manual Switchover

The user can request a manual switchover from an externally wired switch. The request executes the following sequence:

1. Verify that HSSL communication is good and there are no internal faults in the standby controller.
2. Verify that the synchronization process is complete.
3. The master requests the standby to take control.
4. The standby takes control and becomes the master.

5. The controller indicates "Device Download Active" until the LON devices have been successfully updated.

Automatic Switchover

An automatic transfer will be initiated if the master controller goes into an error (self detected internal controller failure, program flow error in the controller, user logic checksum error or application checksum error). An automatic switchover executes the following sequence:

1. Check that the standby controller is online by verifying that HSSL communication is good and there are no internal faults in the standby controller.
2. Verify that the synchronization process is complete.
3. The master requests the standby to take control.
4. The standby takes control and becomes the master.

Replacing a Faulty Controller

If the master controller fails and the standby controller is healthy, an automatic switchover will occur. To replace the failed controller, perform the following steps:

1. Remove power. Disconnect plugs and remove the failed controller.
2. Mount the new controller.
3. Connect the LON to the new controller.
4. Connect the HSSL.
5. Connect any other I/O used.
6. Apply power to the controller.
7. A controller synchronization occurs and the new controller is configured and indicates "Ready" as the standby controller.
8. If preferred, perform a manual switchover to return the primary controller to the master status.

ENHANCED DISCRETE I/O MODULE

The EDIO Module (see Figure 4-6) has 18 LED status indicators, two for the device and two for each channel, located on the front panel. Refer to Tables 4-7 and 4-8 for a description of the LED indicators.

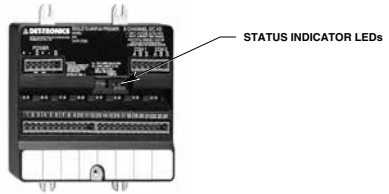

Figure 4-6—EDIO Module Status Indicator Location

POWER-UP SEQUENCE

Set the module address switch prior to applying power.

EDIO module power-up sequence illuminates the LEDs for the device and all of its channels. First the power and fault LEDs are illuminated, indicating that the device is in a power-up mode. Next the LEDs are illuminated in the following sequences:

- Sequentially each channel active red LED is illuminated, starting with channel 1 and continuing through channel 8.
- When the red LED for channel 8 is illuminated, sequentially each channel active red LED is turned off, starting with channel 1 and continuing through channel 8.
- Next, the channel fault amber LEDs are tested in the same manner as the channel active red LEDs.

When all the LEDs have been illuminated, the EDIO module displays the device's LON address by illuminating the channel active red LED. LON dip switches 1 through 8 will be displayed on channels 1 through 8. When a dip switch is set to the ON position, the channel active red LED will be illuminated. The address is displayed for two seconds.

Once the address has been displayed, the device's fault LED will turn off.

After the power-up sequence, the device will either display an unconfigured state or normal operation state. In the unconfigured state, the channel fault amber LEDs flash ON and OFF at the same rate for all channels.

Table 4-7—EDIO Module - Device Status Indicators

LED	Device Status
Green	On when power is present.
Amber	When On steady indicates device is disabled or must be replaced. Possible Watchdog Timer problem. <i>NOTE</i> <i>Blinks one time at power-up.</i>

Table 4-8—EDIO Module - Channel Status Indicators

LED	Channel Status
Red	When On steady indicates the input circuit is closed or the output circuit is active
Amber	When Blinking indicates a low power condition is present or channel is not properly configured. Steady indicates a channel fault.

8 CHANNEL DCIO MODULE

The DCIO Module (see Figure 4-7) has 18 LED status indicators, two for the device and two for each channel, located on the front panel. Refer to Tables 4-9 and 4-10 for a description of the LED indicators.

POWER-UP SEQUENCE

Set the module address switch prior to applying power.

DCIO module power-up sequence illuminates the LEDs for the device and all of its channels. First the power and fault LEDs are illuminated, indicating that the device is in a power-up mode. Next the LEDs are illuminated in the following sequences:

- Sequentially each channel active red LED is illuminated, starting with channel 1 and continuing through channel 8.
- When the red LED for channel 8 is illuminated, sequentially each channel active red LED is turned off, starting with channel 1 and continuing through channel 8.
- Next, the channel fault amber LEDs are tested in the same manner as the channel active red LEDs.

When all the LEDs have been illuminated, the DCIO module displays the device's LON address by illuminating the channel active red LED. LON dip switches 1 through 8 will be displayed on channels 1 through 8. When a dip switch is set to the ON position, the channel active red LED will be illuminated. The address is displayed for two seconds.

Once the address has been displayed, the device's fault LED will turn off.

After the power-up sequence, the device will either display an unconfigured state or normal operation state. In the unconfigured state, the channel fault amber LEDs flash ON and OFF at the same rate for all channels.

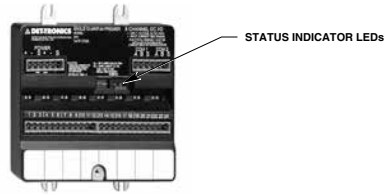

Figure 4-7—DCIO Module Status Indicator Location

Table 4-9—DCIO Module - Device Status Indicators

LED	Device Status
Green	On when power is present.
Amber	When On steady indicates device is disabled or must be replaced. Possible Watchdog Timer problem. <i>NOTE</i> <i>Blinks one time at power-up.</i>

Table 4-10—DCIO Module - Channel Status Indicators

LED	Channel Status
Red	When On steady indicates the input circuit is closed or the output circuit is active
Amber	When Blinking indicates a low power condition is present or channel is not properly configured. Steady indicates a channel fault.

8 CHANNEL RELAY MODULE

The Relay Module (see Figure 4-8) has 18 LED status indicators, two for the device and two for each channel, located on the front panel. Refer to Tables 4-11 and 4-12 for a description of the LED indicators.

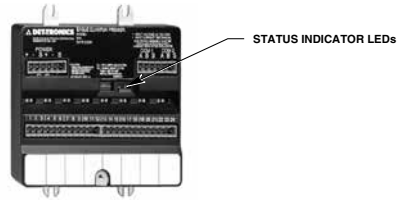

Figure 4-8—Relay Module Status Indicator Location

POWER-UP SEQUENCE

Set the module address switch prior to applying power.

Relay module power-up sequence illuminates the LEDs for the device and all of its channels. First the power and fault LEDs are illuminated, indicating that the device is in a power-up mode. Next the LEDs are illuminated in the following sequences:

- Sequentially each channel active red LED is illuminated, starting with channel 1 and continuing through channel 8.
- When the red LED for channel 8 is illuminated, sequentially each channel active red LED is turned off, starting with channel 1 and continuing through channel 8.
- Next, the channel fault amber LEDs are tested in the same manner as the channel active red LEDs.

When all the LEDs have been illuminated, the relay module displays the device's LON address by illuminating the channel active red LED. LON dip switches 1 through 8 will be displayed on channels 1 through 8. When a dip switch is set to the ON position, the channel active red LED will be illuminated. The address is displayed for two seconds.

Once the address has been displayed, the device's fault LED will turn off.

After the power-up sequence, the device will either display an unconfigured state or normal operation state. In the unconfigured state, the channel fault amber LEDs flash ON and OFF at the same rate for all channels.

Table 4-11—Relay Module - Device Status Indicators

LED	Device Status
Green	On when power is present.
Amber	When On steady indicates device is disabled or must be replaced. Possible Watchdog Timer problem. <i>NOTE</i> <i>Blinks one time at power-up.</i>

Table 4-12—Relay Module - Channel Status Indicators

LED	Channel Status
Red	When On steady indicates the input circuit is active
Amber	When Blinking indicates a low power condition is present or channel is not properly configured.

ANALOG INPUT MODULE

The Analog Input Module (see Figure 4-9) has 18 LED status indicators, two for the device and two for each channel, located on the front panel. Refer to Tables 4-13 and 4-14 for a description of the LED indicators.

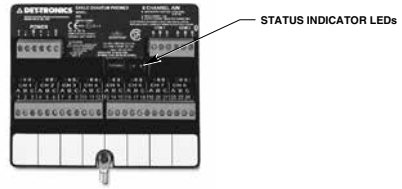

Figure 4-9—Analog Input Module Status Indicator Location

POWER-UP SEQUENCE

Set the module address switch prior to applying power.

The Analog Input Module power-up sequence illuminates the LEDs for the device and all of its channels. First the power and fault LEDs are illuminated, indicating that the device is in a power-up mode. Next the LEDs are illuminated in the following sequences:

- Sequentially each channel active red LED is illuminated, starting with channel 1 and continuing through channel 8.
- When the red LED for channel 8 is illuminated, sequentially each channel active red LED is turned off, starting with channel 1 and continuing through channel 8.
- Next, the channel fault amber LEDs are tested in the same manner as the channel active red LEDs.

When all the LEDs have been illuminated, the analog input module displays the device's LON address by illuminating the channel active red LED. LON dip switches 1 through 8 will be displayed on channels 1 through 8. When a dip switch is set to the ON position, the channel active red LED will be illuminated. The address is displayed for two seconds.

Once the address has been displayed, the device's fault LED will turn off.

After the power-up sequence, the device will either display an unconfigured state or normal operation state. In the unconfigured state, the channel fault amber LEDs flash ON and OFF at the same rate for all channels.

Table 4-13—Analog Input Module - Device Status Indicators

LED	Device Status
Green	On when power is present.
Amber	When On steady indicates device is disabled or must be replaced. Possible Watchdog Timer problem. <i>NOTE</i> <i>Blinks one time at power-up.</i>

Table 4-14—Analog Input Module - Channel Status Indicators

LED	Channel Status
Red	When Blinking indicates a low alarm. When On Steady indicates a high alarm.
Amber	When Blinking indicates a low power condition is present or channel is not properly configured. On steady indicates out of range condition

EQ21XXPSM POWER SUPPLY MONITOR

The power supply monitor (see Figure 4-10) has three LEDs used to provide a visual indication of device status:

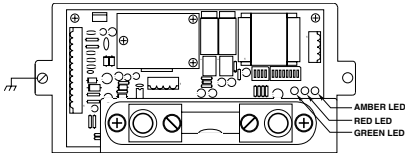

Figure 4-10—EQ21xxPSM Status Indicator Location

Table 4-15—Power Supply Monitor Status Indicators

LED	Device Status
Green	When On indicates power is supplied to device
Red	When Flashing indicates an alarm or fault condition is present.
Amber	When On indicates device is disabled. Module must be replaced.

EQ220GFM GROUND FAULT MONITOR

The ground fault monitor (see Figure 4-11) has three LEDs used to provide a visual indication of device status:

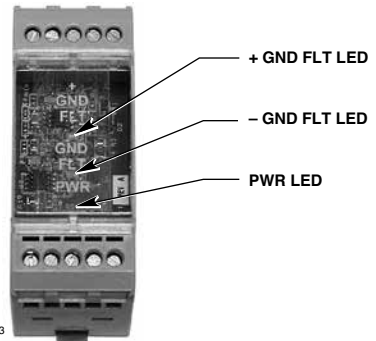

Figure 4-11—Ground Fault Monitor Status Indicator Location

NOTE

The Ground Fault Monitor LED will respond immediately to a ground fault condition. The relay contact requires the condition to exist for 10 seconds before it activates.

Table 4-16—Ground Fault Monitor Status Indicators

LED	Device Status
+ GND FLT LED	Indicates Amber in the presence of a "+" ground fault.
- GND FLT LED	Indicates Amber in the presence of a "-" ground fault.
POWER LED	Indicates Green when the unit is powered.

EQ22XXIDC SERIES INITIATING DEVICE CIRCUIT (IDC)

The IDC has three LEDs (located at the center of the IDC communication module circuit board) to provide a visual indication of device status.

NOTE

The Initiating Device Circuit Ground Fault Monitor responds to the presence of a ground fault within the power circuitry. It provides a supervised dry contact input and ground fault monitoring circuitry for indicating a power supply trouble condition.

NOTE

A blinking red LED on an IDCSC indicates trouble such as a wiring fault (open or short circuit) or not configured.

Table 4-17—Initiating Device Circuit Status Indicators

LED	Device Status
Green	When On indicates device has power
Red	When On indicates an Alarm or Fault condition is present. On steady = One of the inputs is active. Blinking = Fault condition such as an open input circuit or not configured.
Amber	When On indicates a device is disabled. Module must be replaced.

EQ22XXDCU AND EQ22XXDCU EX DIGITAL COMMUNICATION UNITS

The DCUs have three LEDs to provide a visual indication of device status. They are visible through the window on the enclosure cover.

NOTE

If the communication module has not been configured, the red LED blinks at a 4 Hz rate.

NOTE

The amber LED is provided for factory diagnostic purposes and is not used in the system. Illumination of the amber LED normally indicates a failure in the communication chip. Replacement of the communication module circuit board is required.

Table 4-18—DCU Status Indicators

Device Status	LED Status
Power-up	Pulsed at a rate of 0.5 Hz
Calibration	Pulsed at a rate of 1 HZ or on steady
Fault	Pulsed at a rate of 4 Hz
Alarm	On steady

EQ25XXARM AGENT RELEASE MODULE

The EQ25xxARM has three LEDs to indicate device status. They are located at the center of the circuit board.

Table 4-19—Agent Release Module Status Indicators

LED	Device Status
Green	When On indicates device has power.
Red	<p>When On steady indicates an output is activated.</p> <p>When Blinking at a 4 Hz rate with the LED on 50%, off 50% of the time indicates a local trouble condition such as an open output circuit or low solenoid supply voltage.</p> <p>When Blinking at a 1 Hz rate with the LED on 5%, off 95% of the time indicates an isolate condition.</p> <p>When Blinking at a 1 Hz rate with the LED on 95%, off 5% of the time indicates release and isolate.</p>
Amber	When On indicates a malfunction in the electronic circuitry. Module replacement is required.

EQ25XXSAM SIGNAL AUDIBLE MODULE

The EQ25xxSAM has three LEDs to indicate device status. They are located at the center of the circuit board.

Table 4-20—Signal Audible Module Status Indicators

LED	Device Status
Green	When On indicates device has power.
Red	<p>When On steady indicates an Active condition exists.</p> <p>When Blinking indicates a Trouble condition exists.</p>
Amber	When On indicates a malfunction in the electronic circuitry. Module replacement is required.

EQ24XXNE NETWORK EXTENDER

The EQ24xxNE has three LEDs (one green, two amber) for indicating device status.

Table 4-21—Network Extender Status Indicators

LED	Device Status
Green	<p>When On indicates device has power.</p> <p>Flashes to indicate messages are being transferred over the LON.</p>
Amber	<p>When On indicates a malfunction in the electronic circuitry. Module replacement is required.</p> <p>NOTE</p> <p><i>When a network extender has an internal fault, the message display will only indicate that there is a LON fault condition existing somewhere on the LON.</i></p>

SYSTEM STARTUP

PRE-OPERATION CHECKS

General

Insulate all shields to prevent shorts to device housing or to any other conductor.

Place alarm/release output in "Bypass/Isolate" when servicing devices.

Maintain a log book containing the type and serial numbers of devices as well as the location and date of installation.

Maintain a log of maintenance activities.

Observe normal precautions for handling electrostatic sensitive devices.

LON

Rocker switches for each LON device must be set to the desired address prior to power-up.

Test the loop with no power applied. DC resistance should be equal on A and B.

Check polarity on A and B (no rolls). COM 1 connects to COM 2; COM 2 connects to COM 1. A connects to A and B to B.

Measure voltage. A to chassis ground measures approximately +7.5 vdc. B to ground measures approximately -7.5 vdc.

Measure signal (400 mv P-P min.). (Use oscilloscope if possible).

Check fault tolerance by introducing a short.

Controller

The I/O and LON wiring is correctly installed, observing polarity. All cable shields are properly terminated and insulated.

Power wiring is installed and power source is operational.

Chassis ground stud must be connected to earth ground.

Redundant Controller

The I/O and LON wiring is correctly installed, observing polarity. All cable shields are properly terminated and insulated.

Power wiring is installed and power source is operational.

Chassis ground stud must be connected to earth ground.

The HSSL cable is connected between the two controllers.

EDIO/DCIO Module

Verify correct address setting.

Check signal circuits for correct polarity.

Check for correct installation of EOL resistors.

Relay Module

Verify correct address setting.

Check for correct output connections.

Analog Input Module

Verify correct address setting.

Check for correct input connections.

Check each channel with a loop current input.

Power Supplies and Power Monitors

Verify all earth ground connections as specified in the wiring instructions.

Verify correct ac power to supply.

Check power distribution to ensure that all devices are receiving power.

Check power trouble indicator by introducing an open to the battery.

Ground Fault Monitor

Verify earth ground connections as specified in the wiring instructions.

Check power distribution to ensure that all devices are receiving power.

DCUs

Verify correct address setting.

Check modules for correct orientation.

Check for the presence of contaminants or poisoning agents.

Device should be oriented with the sensor pointing down.

IDCs

Verify correct address setting.

Check for correct installation of EOL resistors.

ARMs

Verify correct address setting.

Check jumpers.

SAMs

Verify correct address setting.

Check signal circuits for correct polarity.

Check for correct installation of EOL resistors.

Check jumpers.

GENERAL START-UP PROCEDURES

1. Output loads that are controlled by the system should be secured (remove power from all output devices) to prevent actuation.
2. Check all system wiring for proper connection.
3. Inspect all devices to verify that they have not been physically damaged in shipment.
4. Apply power to the system.

NOTE

To prevent the network modules from going into a fault isolation condition, apply power to the EQP Controller prior to applying power to the network devices.

5. Program the system for the desired operation using Det-Tronics Safety System Software (S³). Download configuration data to all devices.

NOTE

After system configuration has been completed, the entire system should be tested for proper operation to ensure that configuration was performed properly.

6. Calibrate the sensors.
7. Ensure that all trouble and alarm conditions have been cleared and the EQP Controller is reset, then remove mechanical blocking devices (if used) and restore power to the output loads.

START-UP PROCEDURE FOR CONTROLLER

The Controller is powered-up when the Power Supply is turned on. When the Power Supply has been powered-up, verify power at the Controller by verifying that the Green LED indicator is on. This indicator is located on the front of the Controller.

To verify that the Controller is powered-up and operating properly, ensure that:

1. When power is first applied, all LEDs are on. The ACK LED flashes while the memory test is running. When initialization is complete, only the green power LED remains lit.
2. The Ethernet/Serial communication indicators continuously flash (if active).

NOTE

For the Ethernet Interface Board, the blue LEDs associated with ports 3 and 4 will remain on when the ports are ready for communication. Flashing green and amber LEDs indicate active transmit and receive. The amber indicator on the front of the RJ45 connector indicates a 10 Mb/s link is established. The green indicator on the front of the RJ45 connector indicates a 100 Mb/s link is established.

3. The Text display runs an initialization routine. When initialization is complete and if all alarms and trouble conditions are cleared, the text display shows the current time and date. If the controller has been unpowered for more than 12 hours, the time and date may have to be set. If an alarm or trouble condition exists, it will be displayed until the condition is corrected and the Reset button is pressed.

If the controller has not been software configured, unconfigured devices will be displayed. Configuration must be done using S³ Safety System Software before proceeding.

4. The LEDs on the front panel provide an indication of the system status.
5. Ensure configuration was performed properly.

6. After any modifications have been made either to the installation or to configuration software, always check the entire system for proper operation in order to ensure that the changes were performed properly.

STARTUP PROCEDURE FOR EDIO MODULE

Configuration

The EDIO Module is an eight-channel device. Each channel is capable of being configured as an input or output, independent of any other channel.

NOTE

The module is configured using Det-Tronics Safety System Software.

Activation Time

Timers are made available for output circuits only. Timers are used primarily to set the timing of output release in a suppression system. Timers provide a pulse timed output for the time period specified in the configuration of the channel. The channel output goes active when commanded by the system logic and remains on until the timer expires.

Static Logic Mode

Each input channel can be configured as a Fire Alarm, Trouble, Low Gas Alarm, High Gas Alarm, Supervisory, or Other type of channel, independent of any other channel configuration. The type selected determines the logic the system uses to configure Indicators, Alarms and Messages.

For example: When an input is selected as Fire type, the Fire LED on the Controller and Audible alarm will automatically actuate when that input channel is active.

EDIO Startup

1. The Power-on LED should be illuminated. The Fault LED should blink once on power up, then remain off.
2. The input circuits should indicate the proper state of the input device (channel active LED illuminates when the circuit is closed). Check the input power supply and associated wiring. Verify proper voltage per the Troubleshooting matrix.
3. The output circuits should indicate the proper state for the programmed device (channel active LED illuminates when the circuit is active). Check the power supply and associated wiring. Verify proper voltage per the Troubleshooting matrix.
4. The circuits should not indicate a fault condition (channel fault LED illuminates when the circuit is in fault). Check the end-of-line devices and associated wiring. Verify proper voltage per the Troubleshooting matrix.
5. Test the entire system for proper operation to ensure that the configuration was performed properly.

STARTUP PROCEDURE FOR DCIO MODULE

Configuration

The DCIO Module is an eight-channel device. Each channel is capable of being configured as an input or output, independent of any other channel.

NOTE

The module is configured using Det-Tronics Safety System Software.

Activation Time

Timers are made available for output circuits only. Timers are used primarily to set the timing of output release in a suppression system. Timers provide a pulse timed output for the time period specified in the configuration of the channel. The channel output goes active when commanded by the system logic and remains on until the timer expires.

Static Logic Mode

Each input channel can be configured as a Fire Alarm, Trouble, Low Gas Alarm, High Gas Alarm, Supervisory, or Other type of channel, independent of any other channel configuration. The type selected determines the logic the system uses to configure Indicators, Alarms and Messages.

For example: When an input is selected as Fire type, the Fire LED on the Controller and Audible alarm will automatically actuate when that input channel is active.

DCIO Startup

1. The Power-on LED should be illuminated. The Fault LED should blink once on power up, then remain off.
2. The input circuits should indicate the proper state of the input device (channel active LED illuminates when the circuit is closed). Check the input power supply and associated wiring. Verify proper voltage per the Troubleshooting matrix.
3. The output circuits should indicate the proper state for the programmed device (channel active LED illuminates when the circuit is active). Check the power supply and associated wiring. Verify proper voltage per the Troubleshooting matrix.
4. The circuits should not indicate a fault condition (channel fault LED illuminates when the circuit is in fault). Check the end-of-line devices and associated wiring. Verify proper voltage per the Troubleshooting matrix.
5. Test the entire system for proper operation to ensure that the configuration was performed properly.

Relay Module Startup

1. The Power-on LED should be illuminated. The Fault LED should blink once on power up, then remain off.
2. The output circuits should indicate the proper state for the programmed device (channel active LED illuminates when the circuit is active).
3. Test the entire system for proper operation to ensure that the configuration was performed properly.

Analog Input Module Startup

1. The Power-on LED should be illuminated. The Fault LED should blink once on power up, then remain off.
2. The input circuits should indicate the proper state for the programmed device (channel active LED illuminates when the circuit is active).
3. The circuits should not indicate a fault condition (channel fault LED illuminates when the circuit is in fault).
4. Test the entire system for proper operation to ensure that the configuration was performed properly.

Section 5 Maintenance

NOTE

Refer to the *Eagle Quantum Premier System Safety Manual (number 95-8599)* for specific requirements and recommendations applicable to the proper installation, operation, and maintenance of all SIL-Certified EQP systems.

ROUTINE MAINTENANCE

To ensure reliable protection, it is important to check and calibrate the system on a regularly scheduled basis. The frequency of checks is determined by the requirements of the particular installation.

BATTERIES

Batteries **must** be replaced every 48 months, or sooner if required by local codes.



IMPORTANT!

Only sealed batteries are to be used.

MANUAL CHECK OF OUTPUT DEVICES

It is important that response devices be checked initially when the system is installed, as well as periodically during an on-going maintenance program.



CAUTION!

Be sure to secure all output devices that are actuated by the system to prevent unwanted activation of equipment, and remember to place these output devices back into service when the checkout is complete.

O-RING MAINTENANCE



WARNING!

The hazardous area must be de-classified prior to removing a junction box cover with power applied.

A rubber O-ring is used to ensure that the junction box cover will seal tightly and provide protection against water entry. The enclosure

should be opened periodically, and the O-ring inspected for breaks, cracks and dryness.

To test O-ring: remove it from the enclosure and stretch it slightly. If cracks are visible, replace it. If it feels dry, a thin coating of lubricant should be applied. When re-installing the O-ring, be sure that it is properly seated in the housing groove. It is imperative that this O-ring be properly installed and in good condition. Failure to properly maintain it can allow water to enter the enclosure and cause premature failure. A coating of lubricant should also be applied to the threads on the cover before re-assembling the enclosure. This will both lubricate the cover threads and help prevent moisture from entering the enclosure.



CAUTION!

The O-rings should be lubricated with a silicone free grease. The use of other lubricants is not recommended, since they can adversely affect the performance of some sensors. Under no circumstances should a lubricant or compound containing silicone be used on systems using catalytic type combustible gas sensors.

GAS SENSOR MAINTENANCE

All gas sensors must be calibrated on a regular basis. Calibration should typically be performed every 90 days for catalytic and electrochemical sensors.

Catalytic sensors have a finite lifespan. If a successful calibration cannot be performed, replace the sensor and recalibrate following the procedure described in the "Calibration" section below. **Always compare part numbers to be sure that the correct replacement sensor is being used.**



CAUTION!

Exposure of the sensor to high concentrations of combustible gases for extended periods of time can introduce stress to the sensing element and seriously affect its performance. After exposure, recalibration should immediately be performed, and the sensor should be replaced if necessary.

NOTE

Electrochemical sensors have a finite lifespan. If a successful calibration cannot be performed, inspect the hydrophobic filter. If the filter is plugged, replace it and recalibrate the sensor. If the filter is in good condition, replace the sensor. Recalibrate following the procedure described in the "Calibration" section.

CALIBRATION AND ADJUSTMENTS

To ensure optimum performance, calibration must be performed on a regularly scheduled basis. Since each application is different, the length of time between regularly scheduled recalibrations can vary from one installation to the next. In general, the more frequently a system is checked, the greater the reliability.



IMPORTANT!

4 to 20 ma devices not manufactured by Det-Tronics must be pre-calibrated. To ensure adequate protection, calibration must be performed on a regularly scheduled basis.

NOTE

If the calibration procedure is not completed within 12 minutes, the detector will revert back to the previous calibration values. The red LED will blink. The calibration will be logged as aborted.

NOTE

The "Sensor Replacement" calibration procedure must be used for the initial calibration of a new sensor. The "Routine Calibration" procedure can be used for all subsequent calibrations.

NOTE

Some calibration procedures require the operator to activate the reed switch located on a circuit board inside the junction box. See Figure 5-1 for reed switch location. To activate the switch, hold the calibration magnet against the side of the junction box near the switch location approximately one inch above the mounting surface. (Do not open

the junction box.) Hold the calibration magnet in place for approximately 4 seconds to initiate the calibration procedure.

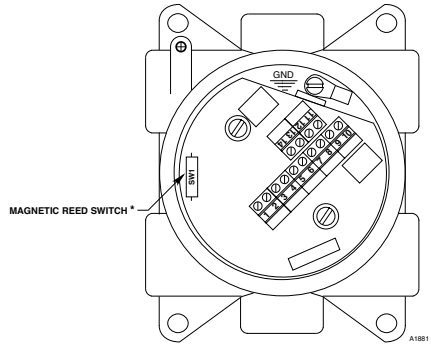

* TO ACTIVATE THE MAGNETIC REED SWITCH, HOLD THE CALIBRATION MAGNET AGAINST THE SIDE OF THE ENCLOSURE AT THE LOCATION OF THE REED SWITCH, APPROXIMATELY ONE INCH ABOVE THE MOUNTING SURFACE.

Figure 5-1—

DCU Terminal Wiring Board Mounted in Six-Port Junction Box

CALIBRATION ALGORITHM A FOR MANUAL CALIBRATION OF UNIVERSAL DCU

Normal Calibration

1. Activate the reed switch. (The red LED blinks while the reed switch is closed.)
2. After the reed switch has been closed for 3 seconds, the calibrate LED blinks, indicating it is ready for the zero input.
3. Enter the zero input (4 ma).
4. Activate the reed switch. (The red LED blinks while the switch is closed.)
5. After the reed switch has been closed for 3 seconds, the communication module records the uncalibrated value in the calibration log and calibrates the zero value. (The calibrate LED stays on steady.)
6. Apply the calibration gas.
7. The calibrate LED blinks as the input increases.
8. Activate the reed switch. (The red LED blinks while the reed switch is closed.)
9. The communication module records the uncalibrated value in the calibration log and calibrates the span value after the reed switch is on for 3 seconds.

10. The calibrate LED stays on steady.
11. Remove the span gas, and return the analog input to normal.
12. Activate the reed switch. (The red LED blinks for 3 seconds while the reed switch is closed.)
13. The calibration is complete. The calibrate LED turns off.

NOTE

If the calibration is not completed within 12 minutes, the previous calibration values are restored and the calibration is logged as aborted. The calibrate LED will flash.

Sensor Replacement



WARNING!

The hazardous area must be de-classified prior to removing a junction box cover with power applied.

1. Open the junction box cover and press the Sensor Replacement Switch.
2. The calibrate LED on the communication module will flash, indicating it is ready for the zero input.
3. Replace the sensor and apply the zero input (4 ma).
4. Activate the reed switch. (The red LED flashes for 3 seconds while the switch is closed.)
5. The communication module records the uncalibrated value in position one of the calibration log and calibrates the zero value. (The calibrate LED stays on steady.)
6. Apply the calibration gas.
7. The calibrate LED flashes when the input increases.
8. Activate the reed switch. (The red LED flashes for 3 seconds while the reed switch is closed.)
9. The communication module records the uncalibrated value in the first register of the calibration log and calibrates the span value.
10. The calibrate LED stays on steady.

11. Remove the span gas and return the analog input to normal.
12. Activate the reed switch. (The red LED flashes for 3 seconds while the switch is closed.)
13. The calibration is complete. (The calibrate LED turns off.)

NOTE

Pressing the Sensor Replacement Switch aborts calibration and starts over.

NOTE

Resetting the communication module will abort the sensor replacement.

**CALIBRATION ALGORITHM C
FOR COMBUSTIBLE GAS DCUS AND
AUTOMATIC CALIBRATION OF
UNIVERSAL DCUs**



CAUTION!

After exposing the H2S sensor to high concentrations of gas, it should be exposed to fresh air for at least 30 minutes, and re-calibrated.

Routine Calibration

1. Apply the zero gas.
 2. Activate the reed switch for at least 4 seconds. (The red LED flashes for 3 seconds while the switch is activated.)
 3. The calibrate LED on the communication module flashes, indicating it is ready for the zero input.
 4. Wait until the calibrate LED stays on steady (approximately 4 seconds).
- NOTE**
- The communication module records the uncalibrated value in the calibration log and calibrates the zero value during this time.*
5. Apply the calibration gas. (The calibrate LED flashes when the sensor detects gas.)
 6. When the sensor input has been stable for 30 seconds, the communication module records the uncalibrated value in the calibration log, and calibrates the span value.

7. The calibrate LED stays on steady.
8. Remove the calibration gas.
9. The communication module waits until the sensor input drops below 4% full scale.
10. The calibration is complete. (The calibrate LED turns off.)

NOTE

If the calibration procedure is not completed within 12 minutes, calibration will be aborted and the detector will revert back to the previous calibration values. The red LED will flash and the calibration will be logged as aborted.

Initial Installation and Sensor Replacement — Combustible Gas (CGS Sensor)

NOTE

When replacing a sensor, compare part numbers to be sure that the correct replacement sensor is used.



WARNING!

The hazardous area must be de-classified prior to removing a junction box cover with power applied.

1. Remove the cover from the DCUEX enclosure.
2. Press the Sensor Replacement Switch on the communication module for approximately 1 second. (The calibrate LED on the communication module flashes, indicating that it is ready for the zero input.)

NOTE

Pressing the sensor replacement switch prevents the communication module from generating a fault signal when the input drops to zero due to sensor removal. The calibration will not be aborted if the calibration procedure is not completed within 12 minutes.

3. Move the Calibration Switch to the “calibrate” position.
4. Replace the sensor.

5. Connect a volt meter to the test points on the transmitter board. Connect the “+” lead to TP1 (red). Connect the “-” lead to TP2 (black).
6. Wait at least 5 minutes for the sensor output to stabilize, then adjust R2 for a reading of 0.40 vdc (4 ma) on the meter.

NOTE

Do not make adjustments to R1 when calibrating the sensor.

7. Move the Calibrate Switch to the “normal” position.
8. Activate the reed switch for 4 seconds. (The red LED flashes for 3 seconds while the switch is activated.) The communication module records the uncalibrated value in position one of the calibration log and calibrates the zero value. The calibrate LED goes on steady.
9. Move the Calibration Switch to the “calibrate” position.
10. Apply the calibration gas and wait for the output to stabilize.
11. With 50% LFL calibration gas applied to sensor, adjust R3 for a reading of 1.2 vdc (12 ma) on the volt meter.
12. Move the Calibrate Switch to the “normal” position. (The red LED flashes.)
13. Activate the reed switch. The red LED flashes for 3 seconds while the switch is activated.
14. The communication module records the uncalibrated value in the first register of the calibration log and calibrates the span value. The calibrate LED stays on steady.
15. Remove the calibration gas and replace the DCU enclosure cover.
16. The communication module waits until the analog value drops below 4% full scale. The calibration is complete. (The calibrate LED turns off.)

NOTE

Pressing the Sensor Replacement Switch aborts the current calibration.

Sensor Replacement — Toxic Gas

NOTE

When replacing a sensor, compare part numbers to be sure the correct replacement sensor is being used.



WARNING!

The hazardous area must be de-classified prior to removing a junction box cover with power applied.

1. Remove the cover from the DCU enclosure.
2. Press the Sensor Replacement Switch on the communication module for approximately 1 second. (The calibrate LED flashes, indicating it is ready for the zero input.)

NOTE

*Pressing the Sensor Replacement Switch prevents the communication module from generating a fault signal when the input drops to zero due to sensor removal. The calibration will **not** be aborted if the calibration procedure is not completed within 12 minutes.*

3. Replace the sensor.
4. Wait at least 5 minutes for the sensor output to stabilize.
5. Activate the reed switch. (The red LED flashes for 3 seconds while the switch is activated.) The communication module records the uncalibrated value in position one of the calibration log and calibrates the zero value. (The calibrate LED stays on steady.)
6. Apply the calibration gas. (The calibrate LED flashes when the input increases.)
7. Activate the reed switch. (The red LED flashes for 3 seconds while the switch is activated.)
8. The communication module records the uncalibrated value in the first register of the calibration log and calibrates the span value. (The calibrate LED stays on steady.)

9. Remove the calibration gas and replace the DCU enclosure cover.
10. The communication module waits until the analog value drops below 4% full scale. The calibration is complete. (The calibrate LED turns off.)

NOTE

Pressing the Sensor Replacement Switch aborts the calibration and starts over.

CALIBRATION ALGORITHM D FOR UNIVERSAL DCUs WITH O₂ SENSOR

Normal Calibration

1. Apply clean air (20.9% oxygen).
2. Activate the reed switch for at least 4 seconds. (The red LED flashes for 3 seconds while the switch is closed.)
3. The calibrate LED flashes, indicating calibration has begun.
4. The communication module waits 3 seconds.
5. The communication module records the uncalibrated value in the calibration log and calibrates the span value.
6. The calibrate LED stays on steady.
7. The communication module waits 3 seconds.
8. Calibration is complete. (The calibrate LED turns off.)

Sensor Replacement



WARNING!

The hazardous area must be de-classified prior to removing a junction box cover with power applied.

1. Open the junction box cover and press the Sensor Replacement Switch.
2. The calibrate LED on the communication module flashes, indicating it is ready for the zero input.
3. Replace the sensor and set the Sensor Switch (located on the sensor cell) to zero.

4. Activate the reed switch. (The red LED flashes for 3 seconds while the switch is closed.)
 5. The communication module records the uncalibrated value in position one of the calibration log and calibrates the zero value. The calibrate LED stays on steady.
 6. Set the Zero Switch on the sensor to the "normal" position. Apply clean air (20.9% oxygen) to set the sensor analog span value.
 7. The calibrate LED flashes when the input goes high.
 8. Activate the reed switch. (The red LED flashes for 3 seconds while the switch is closed.)
 9. The communication module records the uncalibrated value in the first register of the calibration log and calibrates the span value.
 10. The calibration is complete. The calibrate LED turns off.
7. The calibrate LED stays on steady.
 8. Remove the calibration gas.
 9. The communication module waits until the sensor input drops below 4% full scale.
 10. The calibration is complete. (The calibrate LED turns off.)

NOTE

Calibration is aborted if not complete within 12 minutes. If not completed, the detector will revert back to the previous calibration values. The red LED will flash and the calibration will be logged as aborted.

Sensor Replacement



WARNING!

The hazardous area must be de-classified prior to removing a junction box cover with power applied.

1. Remove power from the DCU and PointWatch/DuctWatch unit. Replace the PointWatch unit. Apply power. Press the Sensor Replacement Switch on the communication module for approximately 1 second.

NOTE

Allow at least 10 minutes for the sensor to warm up.

NOTE

Pressing the Sensor Replacement Switch prevents the communication module from generating a fault signal when the input drops to zero.

NOTE

The calibration will not be aborted if the calibration procedure is not completed within 12 minutes

2. Apply zero gas.
3. The calibrate LED flashes, indicating that it is ready for the zero input.
4. Continue from step 4 of the PointWatch/ DuctWatch routine calibration procedure described above.

NOTE

Pressing the sensor replacement switch aborts the calibration.

CALIBRATION ALGORITHM G FOR DCUs WITH POINTWATCH OR DUCTWATCH

Routine Calibration

1. Apply the zero gas.
2. Activate the reed switch for at least 4 seconds. (The red LED flashes for 3 seconds while the switch is activated.)
3. The calibrate LED flashes, indicating it is ready for the zero input.
4. When a steady zero reading is obtained, the communication module records the uncalibrated value in the calibration log and calibrates the zero value during this time. The LED stays on steady.
5. Apply calibration gas. (The calibrate LED flashes when the sensor detects gas.)
6. When the sensor input has been stable for 30 seconds, the communication module records the uncalibrated value in the calibration log and calibrates the span value.

DEVICE CALIBRATION LOGS AND RECORDS

The DCU keeps a calibration log in non-volatile memory that can be used by the operator to evaluate the remaining life of some sensors. This log includes the zero, span, date and time for each successful calibration. An aborted calibration is indicated by zeros in the zero and span values. The calibration log is cleared when the sensor replacement switch is pressed and the calibration is successfully completed.

The initial calibration is logged in position one, where it remains for the life of the sensor. If more than 8 calibrations are performed without the sensor replacement switch being pressed, the newest calibration data will replace the second oldest so that the initial calibration data can be saved. The old calibration data will be lost. This feature enables sensor sensitivity trending to aid in maintenance or troubleshooting.

The analog value for the sensor is represented in raw analog-to-digital counts 0 to 4095, where 0 represents 0 ma and 4095 represents 24 ma.

TROUBLESHOOTING

Tables 5-1 and 5-2 are provided to assist in locating the source of a system problem.

REPLACEMENT PARTS

Eagle Quantum Premier devices are not designed to be repaired in the field. If a problem should develop, first carefully check for proper wiring, programming and calibration.

If it is determined that the problem is caused by an electronic defect, the device must be returned to the factory for repair.

NOTE

When replacing a device, be sure that all rocker switches on the replacement are set the same as the original device. Consult the settings documented during system installation and setup to determine proper settings for the new device. Remove power before removing a device or plugging in a replacement unit. When a device is replaced, configuration is done automatically.

DEVICE REPAIR AND RETURN

Prior to returning devices or components, contact the nearest local Detector Electronics office so that a Service Order number can be assigned. A written statement describing the malfunction must accompany the returned device or component to expedite finding the cause of the failure.

Pack the unit or component properly. Use sufficient packing material in addition to an antistatic bag or aluminum-backed cardboard as protection from electrostatic discharge.

Return all equipment transportation prepaid to the factory in Minneapolis.

Table 5-1—Troubleshooting Guide - DCIO Module

I/O Type	Normal (Off)	Normal (On)	Open (Off)	Open (On)	Short (Off)	Short (On)
Unsupervised Input	-15.4	0	-15.4	-15.4	0	0
Supervised Input (EOL Resistor)	-14.4	0	-15.4	-15.4	0	0
Supervised Input (EOL/Inline Resistors)	-15.4	-15	-15.4	-15.4	0	0
Unsupervised Output	-15.4	23.9	-15.4	23.9	0	0
Supervised Output (Agent Release)	0 to 2.1 Note 2	23.9	-15.4	23.9	0	0
Supervised Output (Notification)	-14.4	23.9	-15.4	23.9	0	0

Notes:

1. All measurements are in Volts and are measured in reference to the common terminal and 24.0 Vdc is the module's input.
2. Value is dependent on the resistance of the solenoid attached.

Table 5-2—System Controller Troubleshooting Guide

Symptom	Possible Cause	Corrective Action
Controller Power LED/ Text Display OFF	No Power to Input.	<ul style="list-style-type: none"> - Measure input voltage (18 to 30 VDC). - Check that P1 is fully inserted. - If voltage is present and P1 is fully inserted, replace controller.
LON Fault – LED lit.	LON wiring is shorted or open.	<ul style="list-style-type: none"> - Check that P7 is fully inserted. - Using the EQ Safety System Software, determine the location of open or short via LON Diagnostics screen. - Use a multimeter to determine wiring fault.
Trouble Relay is Active.	Any monitored device in the system including ground fault in fault condition.	<ul style="list-style-type: none"> - Using the front panel display/controls, view all points in alarm/fault and identify faulted device. - Repair or replace faulted device as necessary.
Digital inputs are not responding.	<ul style="list-style-type: none"> - Bad input switch. - Faulty input channel. - Faulty wiring. - Configuration error. 	<ul style="list-style-type: none"> - Check that P2 and P3 are fully inserted. - Using a voltmeter, measure input terminals with contact closed to the input (measures 0 vdc when input contact is closed, measures approximately 23 vdc with circuit open and 24 vdc input at the controller). - If input does not respond to a contact closure, replace module (verify response with EQ Safety System Software/textual display). - Verify configuration.
Relay Outputs are not respond to an output command	<ul style="list-style-type: none"> - Bad relay channel. - Faulty output wiring. - User logic. 	<ul style="list-style-type: none"> - Check that P4 and P5 are fully inserted. - When output should be energized, measure contact resistance using an ohm meter. - Verify that wiring from output is not open. - Using EQ Safety System Software, verify that logic is trying to operate the channel.
Serial links are not responding.	<ul style="list-style-type: none"> - Faulty wiring. - Incorrect serial link configuration. - Text display shows "Invalid Configuration" 	<ul style="list-style-type: none"> - Check that P8 and P9 are fully inserted. - Verify that communication LEDs are flashing. - Verify that serial link configuration matches the host device. - Verify that wiring is not open or shorted.
Ethernet link are not responding	<ul style="list-style-type: none"> - Faulty wiring. - Incorrect Ethernet link configuration. - Text display shows "Invalid Configuration" 	<ul style="list-style-type: none"> - Check that P3 and P4 are fully inserted. - Verify that communication LEDs are flashing. - Verify that Ethernet link configuration is correct. - Verify that wiring is not open or shorted.
Front panel pushbuttons are not working	<ul style="list-style-type: none"> - Power OFF. - Controller is faulted. 	<ul style="list-style-type: none"> - Verify that power is present and P1 is fully inserted. - Cycle power to controller.
Text display indicates a RTC Fault	Power loss for more than 12 hours	<ul style="list-style-type: none"> - Using the Safety System Software, execute "Set RTC", which downloads the current time into the Controller's real time clock. Alternatively, use the "Set Time and Date" menu in the Controller.

ORDERING INFORMATION

When ordering, please specify:

Refer to the appropriate model matrix in Appendix G for the following devices:

EQ3XXX EQP Controller
EQ3700DCIO Discrete Input/Output Module
EQ3710AIM Analog Input Module
EQ3720RM Relay Module
EQ3730EDIO Enhanced Discrete Input/Output Module

POWER SUPPLIES

Part Number	Description
006979-001	EQ21xxPSM Power Supply Monitor
000604-013	EQ2110PS Power Supply (10 A / 60 Hz)
000604-014	EQ2130PS Power Supply (30 A / 60 Hz)
000604-015	EQ2175PS Power Supply (75 A / 60 Hz)
000604-034	EQ2111PS Power Supply (10 A / 50 Hz)
000604-035	EQ2131PS Power Supply (30 A / 50 Hz)
000604-036	EQ2176PS Power Supply (75 A / 50 Hz)
007941-001	EQ2220GFM Ground Fault Monitor
010988-001	EQP2120PS-B Power Supply, 20A/50-60 Hz, Panel Mount
010988-002	EQP2120PS Power Supply, 20A/50-60 Hz, DIN Rail Mount
010985-001	EQ2110PS-P Power Supply, 10A/50-60 Hz, Panel Mount
010985-002	EQ2110PS Power Supply, 10A/50-60 Hz, DIN Rail Mount
010892-001	EQ2410PS-P Converter, 10A/24 Vdc, Panel Mount
010892-002	EQ2410PS Converter, 10A/24 Vdc, DIN Rail Mount
009934-001	Diode Redundancy Module, with Mounting Bracket
009934-002	Diode Redundancy Module, DIN Rail Mount

LON DEVICES

Part Number	Description
006608-xxx	EQ22xxIDC Initiating Device Circuit
006943-xxx	EQ22xxIDCGF Ground Fault Monitor
007257-xxx	EQ22xxIDCSC Initiating Device Circuit Short Circuit
006607-xxx	EQ22xxDCU Digital Communication Unit (specify gas)
006733-xxx	EQ25xxARM Agent Release Module
006738-xxx	EQ25xxSAM Signal Audible Module
006941-xxx	EQ24xxNE Network Extender
008056-001	HART Interface Module
008982-001	EQ3LTM LON Termination Module

REDUNDANCY

Part Number	Description
008981-001	Controller to Controller High-Speed Serial Link Cable (4 ft)
008982-001	EQ3LTM LON Termination Module

CONTROLLER

COMMUNICATION CABLES

Part Number	Description
007633-001	Controller RS-232 Cable, DB9 Female PC Connection, 15 ft. (4.57 m)
007633-002	Controller RS-232 Cable, DB9 Female PC Connection, 30 ft. (9.14 m)
007633-003	Controller RS-232 Cable, DB9 Female PC Connection, 50 ft. (15.24 m)

For additional information or for assistance in ordering, please contact:

Detector Electronics Corporation
6901 West 110th Street
Minneapolis, Minnesota 55438 USA
Operator: (952) 941-5665 or (800) 765-FIRE
Customer Service: (952) 946-6491
Fax: (952) 829-8750
Web site: www.det-tronics.com
E-mail: det-tronics@det-tronics.com

Section 6 Specifications

NOTE

For USCG Approved System specifications, refer to Appendix D.

EQ3XXX CONTROLLER

INPUT VOLTAGE—

24 vdc nominal, 18 to 30 vdc. 10% overvoltage will not cause damage to the equipment.

INPUT POWER—

9 watts nominal, 12 watts maximum.

LON COMMUNICATION—

Digital communication, transformer isolated (78.5 kbps).

RS-485 COMMUNICATION—

MODBUS Master/Slave capability. Digital communication, transformer isolated (up to 115 kbps).

RS-232 COMMUNICATION—

S³ configuration only. Digital communication, optically isolated.

CONTROLNET—

Digital communication, transformer isolated (5 Mbps).

ETHERNET DLR—

10/100 Mbps Ethernet DLR capability.

ETHERNET INTERFACE BOARD—

RS-485 Communication: MODBUS master/slave capability, ground fault monitored. Digital communication, transformer isolated (up to 230 kbps).

10/100 Mbps BASE-T Ethernet Communication: MODBUS TCP master/slave or S³ configuration capability.

10/100 Mbps BASE-T Ethernet Communication: MODBUS TCP master/slave capability.

High Speed Serial Link (HSSL): Port used only for redundant controller to controller communication.

SERIAL INTERFACE BOARD—

RS-485 Communication: MODBUS master/slave capability, ground fault monitored. Digital communication, transformer isolated (up to 230 kbps).

RS-232 Communication: MODBUS master/slave or S³ configuration capability. Digital communication, non-isolated (up to 230 kbps).

RS-232 Communication: MODBUS master/slave capability. Digital communication, non-isolated (up to 230 kbps).

High Speed Serial Link (HSSL): Port used only for redundant controller to controller communication.

UNSUPERVISED OUTPUTS—

Dry Contact Rating: 1 ampere at 30 vdc maximum. SPDT normally open/normally closed contact, Configurable for normally energized or de-energized (de-energized is the default mode).

UNSUPERVISED INPUTS—

Two State input (on/off). User selectable normally open or normally closed contact (N.O. is the default).

TROUBLE OUTPUT—

SPDT normally open/normally closed contact, Non-Configurable, normally energized only.

TEMPERATURE RANGE—

Operating (Certified Rating): See Certification section below.
Storage: -40°F to +185°F (-40°C to +85°C). Excluding communication port optional modules.

HUMIDITY RANGE—

5 to 95% RH, non-condensing.

VIBRATION—

FM 3260, FM 6310/6320.

DIMENSIONS—

See Figure 6-1.

SHIPPING WEIGHT—

5 pounds (2.3 kilograms).

CERTIFICATION—

FM / CSA: Class I, Div. 2, Groups A, B, C, D (T4).

Class I, Zone 2, Group IIC (T4).

Tamb = -40°C to +80°C.

Performance verified.

Refer to Appendix A for FM Approval details, including Protected Premises Fire Alarm Systems and EQP Supervising Systems.

Refer to Appendix B for CSA Certification details.

Refer to Appendix D for USCG Approval details.

CE: ATEX/EMC Directive Compliant.



ATEX: Ex II 3 G.

Ex nAc nCc IIC T4.

EN 60079-29-1 & EN 60079-29-4.

DEMKO 02 ATEX 133867X.

Tamb* = -40°C to +80°C.

Tamb = -40°C to +70°C.

IECEx: IECEx ULD 10.0004X.

Ex nAc nCc IIC T4.

Tamb* = -40°C to +80°C.

Tamb = -40°C to +70°C.

Note: Refer to Appendix C for ATEX and IECEx approval details and Special Conditions for Safe Use.

*Applicable only if relays 1-7 (terminals 21-41) are configured such that the relay contacts are normally open and de-energized (refer to Figures 3-8 and 3-9 for relay wiring information).

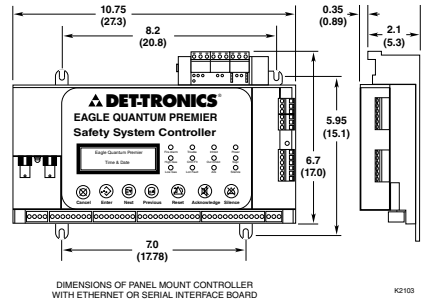
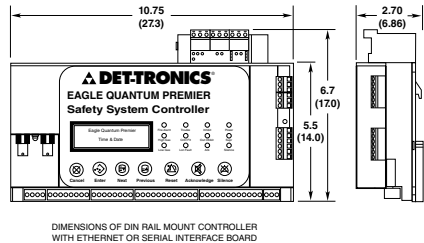
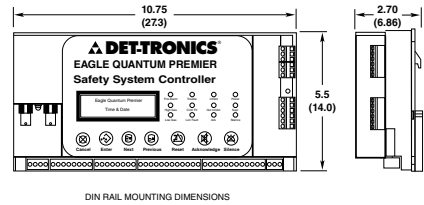
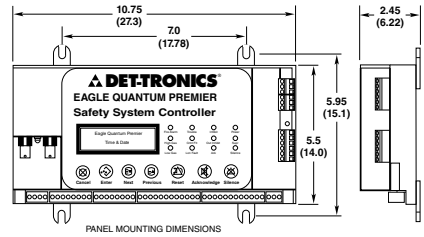

Figure 6-1—Dimensions of EQP Controller in Inches (Centimeters)

EQ3LTM LON TERMINATION MODULE

INPUT VOLTAGE—

24 Vdc nominal, 18 to 30 Vdc. 10% overvoltage will not cause damage to the equipment.

INPUT POWER—

1 watt maximum.

TEMPERATURE RANGE—

Operating: -40°F to $+185^{\circ}\text{F}$ (-40°C to $+85^{\circ}\text{C}$).
Storage: -67°F to $+185^{\circ}\text{F}$ (-55°C to $+85^{\circ}\text{C}$).

HUMIDITY RANGE—

5 to 95% RH, non-condensing.

DIMENSIONS—

See Figure 6-2.

SHIPPING WEIGHT—

0.5 pounds (0.2 kilograms)

CERTIFICATION—

FM / CSA: Class I, Div. 2, Groups A, B, C, D (T4).
Class I, Zone 2, Group IIC (T4).

Refer to Appendix A for FM Approval details.
Refer to Appendix B for CSA Approval details.

CE: ATEX/EMC Directive Compliant.



ATEX:

⊕ II 3 G.



Ex nA IIC T4 Gc.
DEMKO 04 ATEX 138345X.
Tamb = -40°C to $+85^{\circ}\text{C}$.

IECEX:

IECEX ULD 10.0004X.



Ex nA IIC T4 Gc.
Tamb = -40°C to $+85^{\circ}\text{C}$.

Note: Refer to Appendix C for ATEX and IECEX approval details and Special Conditions for Safe Use.

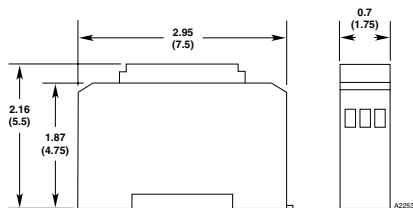

Figure 6-2—Dimensions of LON Termination Module and HART Interface Module in Inches (Centimeters)

EQ3730EDIO ENHANCED DISCRETE INPUT/OUTPUT MODULE

POWER REQUIREMENTS—

3 watts nominal, 11 watts maximum.

INPUT VOLTAGE—

24 Vdc nominal, 18 to 30 Vdc. 10% overvoltage will not cause damage to the equipment.
21 to 30 Vdc for Pre-action / Deluge applications.

Note: For deluge and pre-action applications, input voltage to the device must be 21 Vdc minimum to ensure proper operation of the connected output device.

OUTPUT CURRENT—

10.0 amperes maximum total current, 2.0 amperes maximum per channel.

SLC OUTPUT—

Digital communication, transformer isolated (78.5 kbps).

TEMPERATURE RANGE—

Operating: -40°F to $+185^{\circ}\text{F}$ (-40°C to $+85^{\circ}\text{C}$).
Storage: -67°F to $+185^{\circ}\text{F}$ (-55°C to $+85^{\circ}\text{C}$).

HUMIDITY RANGE—

0 to 95% RH, non-condensing.

VIBRATION—

FM 3260-2000 (clause 4.9).

DIMENSIONS—

Refer to Figure 6-3.

SHIPPING WEIGHT—

1 pound (0.45 kilograms).

CERTIFICATION—

FM / CSA: Class I, Div. 2, Groups A, B, C, D (T4).
Class I, Zone 2, Group IIC (T4).

Refer to Appendix A for FM Approval details.
Refer to Appendix B for CSA Approval details.

CE: ATEX/EMC Directive Compliant.



ATEX:

⊕ II 3 G.



Ex nA nC IIC T4 GC EN 60079-29-1.
DEMKO 05 ATEX 138864X.
Tamb = -40°C to $+85^{\circ}\text{C}$.

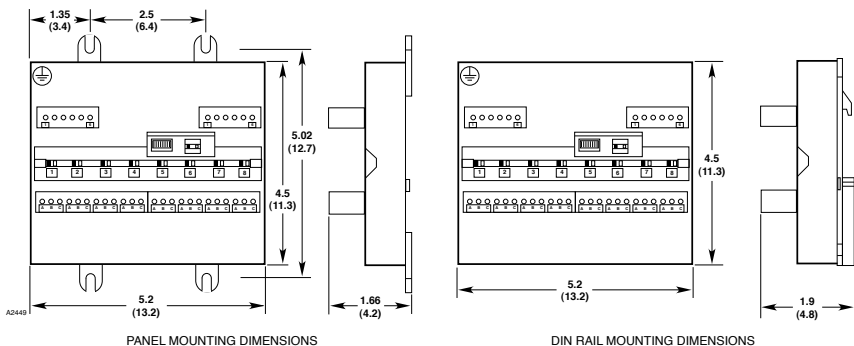

Figure 6-3—Dimensions of the EDIO / DCIO / Relay Module / AIM in Inches (Centimeters)

IECEX: IECEx ULD 10.0004X.
 Ex nA nC IIC T4 GC.
 Tamb = -40°C to +85°C.

Note: Refer to Appendix C for ATEX and IECEx approval details and Special Conditions for Safe Use.

Refer to Appendix D for USCG Approval details.

INPUT / INITIATING DEVICE CIRCUITS

UNSUPERVISED INPUT—

Two state input (on/off).
 Normally open contact.

SUPERVISED INPUT (OPEN CIRCUIT)—

For Class A and Class B wiring.

Two state input (active/trouble):

- End of Line Resistor 10 K ohms nominal
- Open Circuit > 45 K ohms
- Active Circuit < 5 K ohms.

SUPERVISED INPUT (OPEN AND SHORT CIRCUIT)—

For Class A and Class B wiring.

Three State input (active/short/open):

- End of Line Resistor 10 K ohms nominal
- In Line Resistor 3.3 K ohms nominal
- Open Circuit > 45 K ohms
- Short Circuit < 250 ohms
- Active Circuit 2.5 K ohms to 5 K ohms.

INPUT, TYPES—

Configurable for static logic applications:

- Fire Alarm
- Supervisory
- Trouble
- High Gas Alarm
- Low Gas Alarm
- Other.

For Class A wiring on inputs, configure adjacent channels for Class A wiring and connect both channels to single contact device(s).

INPUT CIRCUITS – TWO WIRE SMOKE/HEAT TYPE—

Supervised Input, Class B:

Up to 15 two wire detectors per circuit.

Maximum line resistance 50 ohms.

5K ohm EOL.

Open circuit fault impedance 22k ohms.

OUTPUT / NOTIFICATION / RELEASING OR UNSUPERVISED DEVICE CIRCUITS

UNSUPERVISED OUTPUT RATING

(Per Channel)—

2 amperes at 30 Vdc maximum.

Automatic short circuit protection provided.

Instantaneous short circuit current < 15 amperes.

Note: Voltage available at outputs is dependent on input voltage ($V_{out} \approx V_{in} - 0.5 V_{dc}$).

OUTPUT STYLE—

Form "A" normally off.

RESPONSE TIME—

Output actuates in <0.15 second after acknowledging an alarm command message.

SUPERVISED OUTPUT RATING-SIGNALING CIRCUIT

MAXIMUM OUTPUT CURRENT

(Per Channel)—

2 amperes at 30 Vdc maximum.

Automatic short circuit protection provided.

Instantaneous short circuit current < 15 amperes.

SUPERVISORY CURRENT (Per Channel)—

Reverse current monitored at 1.5 mA, \pm 0.5 mA.

RESPONSE TIME—

Output actuates in <0.15 second after acknowledging an alarm command message.

EOL RESISTORS—

10 K ohms \pm 2 K ohms. Each circuit must have an EOL resistor.

SIGNALING OUTPUT, TYPES—

Configurable for device applications:

- Continuous
- 60 beats per minute
- 120 beats per minute
- Temporal Pattern.

Note: All eight channels are synchronized when programmed as a signaling output.

SUPERVISED OUTPUT RATING-RELEASING CIRCUIT

MAXIMUM OUTPUT CURRENT

(Per Channel)—

2 amperes at 30 Vdc maximum.

Automatic short circuit protection provided.

Instantaneous short circuit current < 15 amperes.

SUPERVISORY CURRENT (Per Channel)—

Monitored at 1.3 mA \pm 0.2 mA.

RESPONSE TIME—

Output actuates in <0.15 second after acknowledging an alarm command message.

RELEASING OUTPUT, TYPES—

Configurable for device applications:

- Continuous
- Timed.

For Class A wiring on outputs, configure adjacent channels for Class A wiring and connect both channels to single output device(s).

NOTE

EDIO SIL has the capability of monitoring solenoid circuits for shorts. The minimum solenoid inductance for correct operation is 100 mH. See Table 3-11 for a list of recommended solenoids.

EQ3700 DISCRETE IO (DCIO) MODULE

POWER REQUIREMENTS—

3 watts nominal, 11 watts maximum.

INPUT VOLTAGE—

24 vdc nominal, 18 to 30 vdc. 10% overvoltage will not cause damage to the equipment.

21 to 30 vdc for Pre-action / Deluge application.

NOTE: For deluge and pre-action applications, input voltage to the device must be 21 vdc minimum to ensure proper operation of the connected output device.

OUTPUT VOLTAGE—

(Input voltage – 0.5 vdc) @ 2 amperes.

OUTPUT CURRENT—

10.0 amperes maximum total current, 2.0 amperes maximum per channel.

LON COMMUNICATION—

Digital communication, transformer isolated (78.5 kbps).

TEMPERATURE RANGE—

Operating: –40°F to +185°F (–40°C to +85°C).

Storage: –67°F to +185°F (–55°C to +85°C).

HUMIDITY RANGE—

5 to 95% RH, non-condensing.

DIMENSIONS—



Refer to Figure 6-3.

SHIPPING WEIGHT—

1 pound (0.45 kilograms).

CERTIFICATION—

FM / CSA: Class I, Div. 2, Groups A, B, C, D (T4).

  Class I, Zone 2, Group IIC (T4).

Refer to Appendix A for FM Approval details.

Refer to Appendix B for CSA Approval details.

CE: ATEX/EMC Directive Compliant.



ATEX:  II 3 G.
Ex nA nC IIC T4 Gc.
DEMKO 02 ATEX 133864X.
Tamb = -40°C to +85°C.

IECEX: IECEx ULD 10.0004X.
 Ex nA nC IIC T4 Gc.
Tamb = -40°C to +85°C.

Note: Refer to Appendix C for ATEX and IECEx approval details and Special Conditions for Safe Use.

INPUT / INITIATING DEVICE CIRCUITS

UNSUPERVISED INPUT—

Two state input (on/off).
Normally open contact.

SUPERVISED INPUT, CLASS B—

Two state input (active/trouble):

- End of Line Resistor 10 K ohms nominal
- Open Circuit > 45 K ohms
- Active Circuit < 5 K ohms.

SUPERVISED INPUT, CLASS B—

Three State input (active/short/open):

- End of Line Resistor 10 K ohms nominal
- In Line Resistor 3.3 K ohms nominal
- Open Circuit > 45 K ohms
- Short Circuit < 1.4 K ohms
- Active Circuit 2.5 K ohms to 5 K ohms.

INPUT, TYPES—

Configurable for fixed logic applications:

- Fire Alarm
- Supervisory
- Trouble
- High Gas Alarm
- Low Gas Alarm
- Other.

OUTPUT / NOTIFICATION / RELEASING CIRCUITS

UNSUPERVISED OUTPUT RATING—

Short circuit protected: 2 amperes at 30 Vdc maximum.

SUPERVISED OUTPUT RATING— SIGNALING CIRCUIT

MAXIMUM OUTPUT CURRENT—

2 amperes maximum, 15 Amp inrush.
Automatic short circuit protection provided.

SUPERVISORY CURRENT—

Reverse current monitored at 3.0 mA, ± 2.0mA.

RESPONSE TIME—

Output actuates in <0.15 second after acknowledging an alarm command message.

EOL RESISTORS—

10 K ohms ±2 K ohms.

SIGNALING OUTPUT, TYPES—

Configurable for device applications:

- Continuous
- 60 beats per second
- 120 beats per second
- Temporal Pattern.

NOTE

All eight channels are synchronized when programmed as a signaling output.

SUPERVISED OUTPUT RATING— RELEASING CIRCUIT

MAXIMUM OUTPUT CURRENT (Per Channel)—

2 amperes maximum, 15 Amp inrush.
Automatic short circuit protection provided.

SUPERVISORY CURRENT—

Monitored at 3.0 mA ±2.0 mA.

RESPONSE TIME—

Output actuates in <0.15 second after acknowledging an alarm command message.

RELEASING OUTPUT, TYPES—

Configurable for device applications:

- Continuous
- Timed.

EQ3720 RELAY MODULE

POWER REQUIREMENTS—

3 watts nominal, 4 watts maximum.

INPUT VOLTAGE—

24 vdc nominal, 18 to 30 vdc. 10% overvoltage will not cause damage to the equipment.

RELAY CONTACTS—

30 VDC, 2 amps resistive.
125 VAC, 0.5 amp resistive (FM and CSA only).

LON COMMUNICATION—

Digital communication, transformer isolated (78.5 kbps).

TEMPERATURE RANGE—

Operating: -40°F to $+185^{\circ}\text{F}$ (-40°C to $+85^{\circ}\text{C}$).
Storage: -67°F to $+185^{\circ}\text{F}$ (-55°C to $+85^{\circ}\text{C}$).

HUMIDITY RANGE—

5 to 95% RH, non-condensing.

DIMENSIONS—

Refer to Figure 6-3.

SHIPPING WEIGHT—

1 pound (0.45 kilograms).

CERTIFICATION—

FM / CSA: Class I, Div. 2, Groups A, B, C, D (T4).
Class I, Zone 2, Group IIC (T4).

Refer to Appendix A for FM Approval details.

Refer to Appendix B for CSA Approval details.

Refer to Appendix D for USCG Approval details.

CE: ATEX/EMC Directive Compliant.



ATEX:  II 3 G.



Ex nA nC IIC T4 Gc.
DEMKO 03 ATEX 135246X.
Tamb = -40°C to $+60^{\circ}\text{C}$.

IECEX: IECEx ULD 10.0004X.



Ex nA nC IIC T4 Gc.
Tamb = -40°C to $+60^{\circ}\text{C}$.

Note: Refer to Appendix C for ATEX and IECEx approval details and Special Conditions for Safe Use.

RESPONSE TIME—

Actuates in <0.15 second after acknowledging an alarm command message.

EQ3710AIM ANALOG INPUT MODULE

POWER REQUIREMENTS—

Module power consumption: 6 watts.

When supplying power to three-wire transmitters:

Maximum current at power input: 7.4 amperes.

Output current: 900 mA per channel maximum.

INPUT/OUTPUT VOLTAGE—

24 vdc nominal, 18 to 30 vdc. 10% overvoltage will not cause damage to the equipment.

TEMPERATURE RANGE—

Operating: -40°F to $+185^{\circ}\text{F}$ (-40°C to $+85^{\circ}\text{C}$).

Storage: -67°F to $+185^{\circ}\text{F}$ (-55°C to $+85^{\circ}\text{C}$).

HUMIDITY RANGE—

0 to 95% RH, non-condensing.

CHANNEL ACCURACY—

Zero: $\pm 0.3\%$ full scale from -40°C to $+85^{\circ}\text{C}$.

Span: $\pm 0.5\%$ full scale from -40°C to $+85^{\circ}\text{C}$.

RESPONSE TIME—

1 to 100 LON devices: < 2 seconds

101 to 200 LON devices: < 3 seconds

201 to 246 LON devices: < 4 seconds.

LON COMMUNICATION—

Digital communication, transformer isolated (78.5 kbps).

DIMENSIONS—

Refer to Figure 6-3.

SHIPPING WEIGHT—

1 pound (0.45 kilograms).

CERTIFICATION—

FM / CSA: Class I, Div. 2, Groups A, B, C, D (T4).
Class I, Zone 2, Group IIC (T4).

Refer to Appendix A for FM Approval details.

Refer to Appendix B for CSA Approval details.

CE: ATEX/EMC Directive Compliant.



ATEX:  II 3 G.

 Ex nA nC IIC T4 Gc EN60079-29-1.
DEMKO 03 ATEX 136207X.

Tamb = -40°C to $+85^{\circ}\text{C}$.

IECEX: IECEx ULD 10.0004X.



Ex nA nC IIC T4 Gc.
Tamb = -40°C to $+85^{\circ}\text{C}$.

Note: Refer to Appendix C for ATEX and IECEx approval details and Special Conditions for Safe Use.

Refer to Appendix D for USCG Approval details.

HART INTERFACE MODULE (HIM)

INPUT VOLTAGE—

24 vdc nominal, 18 to 30 vdc. 10% overvoltage will not cause damage to the equipment.

INPUT POWER—

1.0 watt maximum.

INPUT/OUTPUT CURRENT—

Operating: 4 -20 mA.

Maximum: 0-30 mA.

TEMPERATURE RANGE—

Operating: -40°F to +185°F (-40°C to +85°C).

Storage: -67°F to +185°F (-55°C to +85°C).

HUMIDITY RANGE—

5 to 95% RH, non-condensing.

DIMENSIONS—

See Figure 6-2.

SHIPPING WEIGHT—

0.5 pounds (0.2 kilograms)

CERTIFICATION—

FM / CSA: Class I, Div. 2, Groups A, B, C, D (T4).

Class I, Zone 2, Group IIC (T4).



CE: ATEX/EMC Directive Compliant.



ATEX

Ex II 3 G.

Ex nA IIC T4 Gc.

DEMKO 04 ATEX 136507X.

T_{amb} = -40°C to +85°C.



IECEX: IECEx ULD 10.0004X.

Ex nA IIC T4 Gc.

T_{amb} = -40°C to +85°C.



Note: Refer to Appendix C for ATEX and IECEx approval details and Special Conditions for Safe Use.

EQ21XXPS POWER SUPPLIES

INPUT VOLTAGE—

Selectable for 120, 208 or 240 vac input power, ±10%.

INPUT CURRENT—

60 Hz Models:

EQ2110PS: 4 amps at 120 VAC

EQ2130PS: 11 / 6 / 6 amps at 120 / 208 / 240 VAC

EQ2175PS: 24 / 15 / 12 amps at 120 / 208 / 240 VAC.

50 Hz Models:

EQ2111PS: 4 amps at 120 VAC

EQ2131PS: 6 amps at 240 VAC

EQ2176PS: 12 amps at 240 VAC.

OUTPUT CURRENT—

EQ2110PS / EQ2111PS: 10 amperes at 24 VDC

EQ2130PS / EQ2131PS: 30 amperes at 24 VDC

EQ2175PS / EQ2176PS: 75 amperes at 24 VDC.

POWER CONSUMPTION—

EQ2110PS / EQ2111PS: 46 Watts

EQ2130PS / EQ2131PS: 140 Watts

EQ2175PS / EQ2176PS: 349 Watts.

TEMPERATURE RANGE—

Operating: +32°F to +122°F (0°C to +50°C)

Storage: -40°F to +185°F (-40°C to +85°C).

HUMIDITY RANGE—

5 to 95% RH, non-condensing.

DIMENSIONS—

in Inches (Centimeters)

	Width	Height	Depth
EQ211xPS:	19 (48.3)	7 (17.8)	15 (38.1)
EQ213xPS:	19 (48.3)	14 (35.6)	15 (38.1)
EQ217xPS:	19 (48.3)	14 (35.6)	15 (38.1)

NOTE

Power supplies are designed for mounting in a standard 19 inch rack. Optional mounting hardware is available for floor or wall mount applications.

CERTIFICATION—

FM / CSA: Ordinary locations.

EQP2XX0PS(-X) POWER SUPPLIES

INPUT VOLTAGE—

EQP2110PS(-P), EQP2120PS(-B): Auto selectable for 120/220 Vac, -15%, +10%; 60/50 Hz, single phase;
EQP2410PS(-P) Converter: 24 Vdc, -15%, +10%.

INPUT CURRENT—

EQP2110PS(-P): 3.2 A max @ 120 Vac
1.7 A max @ 220 Vac
EQP2120PS(-B): 6.6 A max @ 120 Vac
3.6 A max @ 220 Vac
EQP2410PS(-P): 15.7 A @ max @ 24 Vdc

OUTPUT VOLTAGE—

24.5 Vdc nominal, 24.5 to 28.0 Vdc.

OUTPUT CURRENT—

EQP2110PS(-P): 10 A
EQP2120PS(-B): 20 A
EQP2410PS(-P): 10 A

TEMPERATURE RANGE (ALL MODELS)—

Operating: -13°F to +131°F (-25°C to +55°C)
(All Applications)
Storage: -40°F to +185°F (-40°C to +85°C)

HUMIDITY RANGE—

5 to 95% RH at 25°C, non-condensing.

DIMENSIONS—

In Inches (Centimeters)

	Width	Height	Depth
EQP2110PS(-P):	3.35(8.5)	5.2(13.0)	5.0(12.5)
EQP2120PS(-B):	3.54(9)	5.2(13.0)	5.0(12.5)
EQP2410PS(-P):	3.2(8.0)	5.2(13.0)	5.0(12.5)

NOTE

Power supplies are designed for DIN rail or panel mounting (-B or -P suffix).

CERTIFICATION—

FM / CSA: Ordinary locations.
USCG: Refer to Appendix D for details.

REDUNDANCY MODULE QUINT-DIODE/40

TEMPERATURE RANGE—

Operating: -13°F to +131°F (-25°C to +55°C)
(All Applications)
Storage: -40°F to +185°F (-40°C to +85°C).

HUMIDITY RANGE—

5 to 95% RH, non-condensing.

DIMENSIONS—

in Inches (Centimeters)

Width	Height	Depth
2.4 (6.2)	4 (10.2)	3.3 (8.4)

EQ21XXPSM POWER SUPPLY MONITOR

INPUT VOLTAGE—

24 vdc nominal, 18 to 30 Vdc.

POWER CONSUMPTION—

2.0 watts maximum.

MEASUREMENT RANGE—

AC Voltage: 240 vac maximum.

DC Battery Charging Current: 75 amperes maximum.

OUTPUT—

Digital communication, transformer isolated (78.5 k bps).

TEMPERATURE RANGE—

Operating: +32°F to +122°F (0°C to +50°C)

Storage: -67°F to +185°F (-55°C to +85°C).

HUMIDITY RANGE—

5 to 95% RH, non-condensing.

DIMENSIONS—

See Figure 6-4.

CERTIFICATION—

FM / CSA: Ordinary locations.

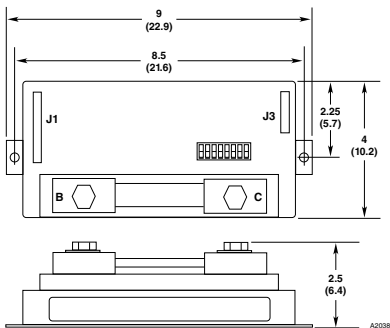

Figure 6-4—Dimensions of Power Supply Monitor in Inches (CM)

EQ22xxIDC/IDCGF INITIATING DEVICE CIRCUIT

INPUT VOLTAGE—

24 vdc nominal, 18 to 30 vdc. 10% overvoltage will not cause damage to the equipment.

INPUT POWER—

4.0 watts maximum.

INPUTS—

Two supervised non-incendive digital inputs (sealed or unsealed switch or relay contacts). 10 kohm EOL resistors are required.

OUTPUTS—

Digital communication, transformer isolated (78.5 kbps).

TEMPERATURE RANGE—

Operating: -40°F to +167°F (-40°C to +75°C).

Storage: -67°F to +185°F (-55°C to +85°C).

HUMIDITY RANGE—

5 to 95% RH, non-condensing.

VIBRATION—

FM 3260.

DIMENSIONS—

See Figure 6-5.

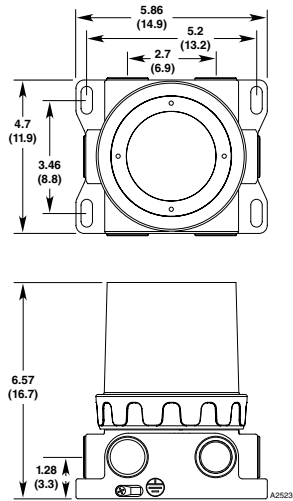

Figure 6-5—Dimensions of Tall Cover Junction Box in Inches (Centimeters)

CERTIFICATION—

FM / CSA: Class I, Div. 1, Groups B, C, D.
Class I, Zone 1, Group IIC.
Class II/III, Div. 1, Groups E, F, G.
Class I, Div. 2, Groups A, B, C, D (T4).
Class I, Zone 2, Group IIC (T4).
Class II/III, Div. 2, Groups F & G (T4).
NEMA/Type 4X.

Refer to Appendix A for FM Approval details.
Refer to Appendix B for CSA Approval details.

CE: ATEX/EMC Directive Compliant.



Refer to Appendix C for ATEX Approval details.

ATEX: **CE** 0539 **Ex** II 2 G



Ex db IIC T4-T6
DEMKO 02 ATEX 131321X
T6 (Tamb = -55°C to +50°C)
T5 (Tamb = -55°C to +65°C)
T4 (Tamb = -55°C to +75°C)
IP66

IEC: IECEx ULD 10.0010



Ex d IIC T4-T6 Gb
T6 (Tamb = -55°C to +50°C)
T5 (Tamb = -55°C to +65°C)
T4 (Tamb = -55°C to +75°C)

Refer to Appendix E for CE Mark details.

EQ2220GFM GROUND FAULT MONITOR

INPUT VOLTAGE—

24 vdc nominal, 18 to 30 vdc. 10% overvoltage will not cause damage to the equipment.

INPUT POWER—

1.0 watt maximum.

OUTPUT—

Form C NO/NC relay contact rated 1 ampere (resistive) at 30 Vdc maximum.

TEMPERATURE RANGE—

Operating: -40°F to +185°F (-40°C to +85°C).
Storage: -67°F to +185°F (-55°C to +85°C).

HUMIDITY RANGE—

5 to 95% RH, non-condensing.

DIMENSIONS—

See Figure 6-6.

SHIPPING WEIGHT—

0.5 pounds (0.2 kilograms)

CERTIFICATION—

FM / CSA: Class I, Div. 2, Groups A, B, C, D (T4).
Ex Class I, Zone 2, Group IIC (T4).



Refer to Appendix A for FM Approval details.
Refer to Appendix B for CSA Approval details.

CE: ATEX/EMC Directive Compliant.



ATEX: **Ex** II 3 G



Ex nC IIC T4 Gc
DEMKO 03 ATEX 136222X
Tamb = -40°C to +85°C

IECEx: IECEx ULD 10.0004X



Ex nC IIC T4 Gc
Tamb = -40°C to +85°C

Note: Refer to Appendix C for ATEX Approval and Appendix E for CE Mark details and Special Conditions for Safe Use.

Refer to Appendix D for USCG Approval details.

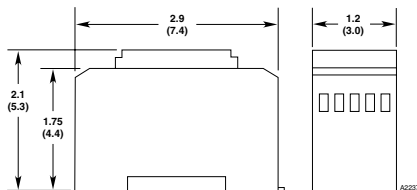

Figure 6-6—Dimensions of Ground Fault Monitor in Inches (Centimeters)

EQ2XXDCU AND EQ2XXDCUEX DIGITAL COMMUNICATION UNIT

INPUT VOLTAGE—

24 vdc nominal, 18 to 30 vdc. 10% overvoltage will not cause damage to the equipment.

POWER CONSUMPTION—

DCU with toxic gas sensor/transmitter: 95 ma max.

DCU with transmitter and combustible gas sensor: 180 ma maximum during normal operation, 500 ma during startup.

INPUTS—

4 - 20 mA analog signal, non-intrusive calibration.

OUTPUTS—

Digital communication, transformer isolated (78.5 kbps).

TEMPERATURE RANGE—

Operating: -40°F to +167°F (-40°C to +75°C).
Storage: -67°F to +185°F (-55°C to +85°C).

HUMIDITY RANGE—

5 to 95% RH, non-condensing.

VIBRATION—

FM 6310/6320.

DIMENSIONS—

See Figure 6-5.

CERTIFICATION—

FM / CSA: Class I, Div. 1, Groups B, C, D.
Class I, Zone 1, Group IIC.
Class I, Div. 2, Groups A, B, C, D (T4).
Class I, Zone 2, Group IIC (T4).
Class II/III, Div. 1 & 2 (for use with Model STB).
NEMA/Type 4X (for use with Model STB).

Refer to Appendix A for FM Approval details.
Refer to Appendix B for CSA Approval details.

CE: ATEX/EMC Directive Compliant.



ATEX:



CE 0539 Ex II 2 G
Ex db IIC T4-T6 EN 60079-29-1
DEMKO 02 ATEX 131321X
T6 (Tamb = -55°C to +50°C)
T5 (Tamb = -55°C to +65°C)
T4 (Tamb = -55°C to +75°C)
IP66

Refer to Appendix C for ATEX Approval details.

Special Conditions for Safe Use (X):

The device has an ambient temperature rating for performance of -40°C to +75°C.

IEC: IECEX ULD 10.0010



Ex d IIC T4-T6 Gb
T6 (Tamb = -55°C to +50°C)
T5 (Tamb = -55°C to +65°C)
T4 (Tamb = -55°C to +75°C)

Refer to Appendix D for USCG Approval details.

Refer to Appendix E for CE Mark details.

EQ25xxARM AGENT RELEASE MODULE

RELEASE OUTPUT RATING—
2 amperes at 30 vdc maximum.

SUPERVISORY CURRENT—
2.0 ma, ± 1.0 ma each circuit.

INPUT VOLTAGE—
24 vdc nominal, 18 to 30 vdc. 10% overvoltage will not cause damage to the equipment.
NOTE: For deluge and pre-action applications, input voltage to the device must be 21 vdc minimum to ensure proper operation of the connected output device.

INPUT CURRENT—
Standby: 75 ma maximum at 24 vdc.
Alarm: 120 ma maximum at 24 vdc.



STATUS OUTPUTS—
Digital communication, transformer isolated (78.5 kbps).

TEMPERATURE RANGE—
Operating: -40°F to $+167^{\circ}\text{F}$ (-40°C to $+75^{\circ}\text{C}$).
Storage: -67°F to $+185^{\circ}\text{F}$ (-55°C to $+85^{\circ}\text{C}$).

HUMIDITY RANGE—
5 to 95% RH, non-condensing.

VIBRATION—
Meets MIL SPEC 810C, method 514.2, curve AW.



DIMENSIONS—
See Figure 6-5.

CERTIFICATION—
FM / CSA: Class I, Div. 1, Groups B, C, D.
 Class I, Zone 1, Group IIC.
 Class II/III, Div. 1, Groups E, F, G.
Class I, Div. 2, Groups A, B, C, D (T4).
Class I, Zone 2, Group IIC (T4).
Class II/III, Div. 2, Groups F & G (T4).
NEMA/Type 4X.

Refer to Appendix A for FM Approval details.
Refer to Appendix B for CSA Approval details.

CE: ATEX/EMC Directive Compliant.



ATEX:  **CE** 0539  II 2 G
Ex db IIC T4-T6
DEMKO 02 ATEX 131321X
T6 (Tamb = -55°C to $+50^{\circ}\text{C}$)
T5 (Tamb = -55°C to $+65^{\circ}\text{C}$)
T4 (Tamb = -55°C to $+75^{\circ}\text{C}$)
IP66

Refer to Appendix C for ATEX Approval details.

IEC:  **IECEx** ULD 10.0010
Ex d IIC T4-T6 Gb
T6 (Tamb = -55°C to $+50^{\circ}\text{C}$)
T5 (Tamb = -55°C to $+65^{\circ}\text{C}$)
T4 (Tamb = -55°C to $+75^{\circ}\text{C}$)

Refer to Appendix E for CE Mark details.

EQ25xxSAM SIGNAL AUDIBLE MODULE

OUTPUT RATING—

2 amperes at 30 vdc maximum.

RESPONSE TIME—

Output relay actuates in <0.1 second after acknowledging an alarm command message.

SUPERVISORY CURRENT—

3.0 ma \pm 2.0ma, each circuit.

EOL RESISTORS —

10 kohm \pm 2 kohm. Each circuit must have an EOL resistor.

INPUT VOLTAGE—

24 vdc nominal, 18 to 30 vdc. 10% overvoltage will not cause damage to the equipment.

INPUT CURRENT (Excluding Output Current)—

Standby: 60 ma maximum at 24 vdc.

Alarm: 120 ma maximum at 24 vdc.

STATUS OUTPUT—

Digital communication, transformer isolated (78.5 kbps).

TEMPERATURE RANGE—

Operating: -40°F to $+167^{\circ}\text{F}$ (-40°C to $+75^{\circ}\text{C}$).

Storage: -67°F to $+185^{\circ}\text{F}$ (-55°C to $+85^{\circ}\text{C}$).

HUMIDITY RANGE—

5 to 95% RH, non-condensing.

VIBRATION—

Meets MIL SPEC 810C, method 514.2, curve AW.

DIMENSIONS—

See Figure 6-5.

CERTIFICATION—

FM / CSA: Class I, Div. 1, Groups B, C, D.

Class I, Zone 1, Group IIC.

Class II/III, Div. 1, Groups E, F, G.

Class I, Div. 2, Groups A, B, C, D (T4).

Class I, Zone 2, Group IIC (T4).

Class II/III, Div. 2, Groups F & G (T4).

NEMA/Type 4X.

Refer to Appendix A for FM Approval details.

Refer to Appendix B for CSA Approval details.

CE: ATEX/EMC Directive Compliant.



ATEX: 0539 II 2 G

Ex db IIC T4-T6

DEMKO 02 ATEX 131321X

T6 (Tamb = -55°C to $+50^{\circ}\text{C}$)

T5 (Tamb = -55°C to $+65^{\circ}\text{C}$)

T4 (Tamb = -55°C to $+75^{\circ}\text{C}$)

IP66

Refer to Appendix C for ATEX Approval details.

IEC: IECEx ULD 10.0010

Ex d IIC T4-T6 Gb

T6 (Tamb = -55°C to $+50^{\circ}\text{C}$)

T5 (Tamb = -55°C to $+65^{\circ}\text{C}$)

T4 (Tamb = -55°C to $+75^{\circ}\text{C}$)

Refer to Appendix E for CE Mark details.



EQ24xxNE NETWORK EXTENDER

INPUT VOLTAGE—

24 vdc nominal, 18 to 30 vdc. 10% overvoltage will not cause damage to the equipment.

POWER CONSUMPTION—

2.2 watts nominal at 24 vdc, 2.7 watts maximum.

INPUTS/OUTPUTS—

Digital, transformer isolated (78.5k Baud).

TEMPERATURE RANGE—

Operating: -40°F to +167°F (-40°C to +75°C)
Storage: -67°F to +185°F (-55°C to +85°C).

HUMIDITY—

5 to 95% RH at 70°C.

DIMENSIONS—

See Figure 6-7.

CERTIFICATION—

FM / CSA: Class I, Div. 1, Groups B, C, D.
Class I, Zone 1, Group IIC.
Class II/III, Div. 1, Groups E, F, G.
Class I, Div. 2, Groups A, B, C, D (T4).
Class I, Zone 2, Group IIC (T4).
Class II/III, Div. 2, Groups F & G (T4).
NEMA/Type 4X.

Refer to Appendix A for FM Approval details.
Refer to Appendix B for CSA Approval details.

CE: ATEX/EMC Directive Compliant.



ATEX: **CE** 0539  II 2 G.

 Ex db IIC T4-T6
DEMKO 02 ATEX 131321X
T6 (Tamb = -55°C to +50°C)
T5 (Tamb = -55°C to +65°C)
T4 (Tamb = -55°C to +75°C)
IP66

Refer to Appendix C for ATEX Approval details.

IEC: IECEx ULD 10.0010

 Ex d IIC T4-T6 Gb
T6 (Tamb = -55°C to +50°C)
T5 (Tamb = -55°C to +65°C)
T4 (Tamb = -55°C to +75°C)

Refer to Appendix D for USCG Approval details.

Refer to Appendix E for CE Mark details.

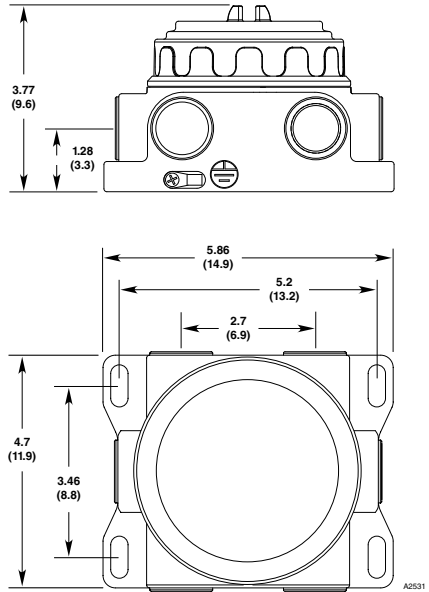

Figure 6-7—Dimensions of Short Cover Junction Box in Inches (Centimeters)

EQ3750ASH ADDRESSABLE SMOKE & HEAT MODULE

For complete information regarding the ASH Module, refer to instruction manual number 95-8654.

COMBUSTIBLE GAS SENSOR

Refer to the Combustible Gas Sensor Specification Data sheet, form 90-1041, for specifications.

ELECTROCHEMICAL SENSORS

Refer to the Electrochemical Gas Sensor Specification Data sheet, form 90-1079, for specifications. Electrochemical sensors available from Det-Tronics include Hydrogen Sulfide, Oxygen, Carbon Monoxide, Chlorine, Sulfur Dioxide, and Nitrogen Dioxide.

EQ21XXPS POWER SUPPLY

The EQ21xxPS Rectifier / Power Supply has many inherent advantages such as voltage regulation, high efficiency, high power factor and short circuit protection.

These chargers provide separate adjustable voltages for floating or equalizing lead or nickel-cadmium cells. An equalize switch is located on the front panel of the charger for manual activation or a multi-mode electronic timer can be used for automatic activation.

Steady state output voltage remains within +/- 1/2% of the setting from no load to full load and for AC input voltages within +/- 10% of the nominal input voltage. The power supply is internally filtered to be no greater than 32dBrn ("C" message weighting) and 30 millivolts RMS for all conditions on input voltage and output load with or without batteries connected. This allows the A36D to be used as a battery eliminator.

APPENDIX A

FM APPROVAL DESCRIPTION

HAZARDOUS LOCATIONS

- Refer to Figures A-1 and A-2 for System Classification details.
- EQxxxxEM versions rated nonincendive for Class I, Div. 2, Groups A, B, C, D (T4A).

FIRE DETECTION & RELEASING

- National Fire Alarm Code performance verified per ANSI/NFPA 72-2010. Refer to Table A-1 for supervision characteristics.
- Refer to the Model X3301, X5200, X2200 and X9800 manuals (see Table 2-4) for further FM flame performance details. Additional 2 second response time applied for system communication.
- Models EQ3700 Series and EQ22xxARM Series are Approved as agent releasing circuits and are Approved for use with the following automatic deluge and pre-action solenoids:

Solenoids		
FM Solenoid Group	Manufacturer	Model
B	ASCO	T8210A107
D	ASCO	8210G207
E	Skinner	73218BN4UNLVNOC111C2
F	Skinner	73212BN4TNLVNOC322C2
G	Skinner	71395SN2ENJ1NOH111C2
H	Viking	11601

GAS DETECTION

- Combustible Gas Performance verified for 0 to 100% LFL methane-in-air atmospheres per FM 6310/6320. Accuracy: $\pm 3\%$ LFL from 0 to 50% LFL, $\pm 5\%$ LFL from 51% to 100% LFL. For the Model PIRECL, refer to the PIRECL manual (form number 95-8526) for further FM gas performance details.

NOTE: Detector Electronics combustible gas detection K factors are not FM verified.

- H2S Toxic Gas Performance verified 0 to 20, 50 or 100 ppm per FM requirements. Accuracy: ± 2 ppm from 0 to 20 ppm, $\pm 10\%$ of concentration from 21 to 100 ppm. Models C7064E4012 and C7064E5012 Hydrogen Sulfide (H2S) Sensors Explosion-proof for Class I, Div. 1, Groups C and D Hazardous (Classified) Locations per FM 3615. Model C7064E5014 Hydrogen Sulfide (H2S) Sensors Explosion-proof for Class I, Div. 1, Groups B, C and D Hazardous (Classified) Locations per FM 3615. Operating temperature limits are -40°C to $+40^{\circ}\text{C}$.

NOTE: Sensor cross sensitivity has not been verified by FM.

- Calibration of the above listed sensors has been FM verified using the respective EQ22xxDCU, EQ22xxDCUEX, and PIRECL with the Det-Tronics 225130-001 (50% LFL methane) and/or 227115-001 H2S Calibration Kits.
- The EQ22xxDCU Series can be used with any FM Approved 4-20 ma device.

NOTE

FM Approval of the 4-20 ma input does not include or imply approval of the gas detection apparatus such as sensors, transmitters, or devices connected to the system. In order to maintain FM Approval of the system, all 4-20 ma gas detection instruments connected to the input must also be FM Approved.

NOTE

FM Approval allows the presence and operation of serial/Ethernet communications software in the Controller (MODBUS TCP/IP, Allen Bradley protocols, etc.); however, the communications functions are not included in the Approval.

EQPSS SUPERVISING SYSTEM

- National Fire Alarm Code performance verified per ANSI/NFPA 72-2002. Refer to Figures A-2 and B-2 for EQPSS Supervising System architecture.
- Det-Tronics only to integrate proprietary EQPSS Supervising System per Det-Tronics Procedures 5072 and 5073.

EQP SYSTEM MODEL 000523-009 & 000523-010

- The System consists of:
 - 1 x EQP2120PS-B Power Supply, primary;
 - 2 x EQP2410PS-P Converter, secondary;
 - 2 x QUINT-DIODE/40 Redundancy module;
 - 1 x EQ2220GFM Ground Fault Monitor

 - 1 x EQ3XXX Controller (000523-009)
 - 0 x EQ3XXX Controller (000523-010)
 - 0 x EQ3710AIM Module & 1 x EQ3730EDIO Module (000523-009)
 - 2 x EQ3710AIM Modules & 2 x EQ3730EDIO Modules (000523-010)
- The System is mounted within 60H x 36W x 16D Stainless Steel (type 316), NRTL labeled NEMA 4X rated enclosure. The enclosure shall be lockable by key lock or padlock.
- EQP system models 000523-009 & 000523-010 are suitable for CI I, Div. 2, GRPS A, B, C & D (T4); CI I, Zone 2, GRP IIC (T4) Hazardous (Classified) Locations; Tamb = -20°C to +49°C.
- Modifications to enclosure (such as conduit entry holes, windows etc.) are permitted when implemented by the manufacturer of the enclosure.

Table A-1—Circuit Classifications

Signaling Path	NFPA 72: 2010 Supervision
Local Operating Network (LON)	Signaling Line Circuit (SLC): Class X
Power Distribution Module, Input Power	Supervised. Loss of power per ANSI/NFPA 72, Cl. 10.17.3.
Power Distribution Module, Controller Power Output	Supervised. Loss of power per ANSI/NFPA 72, Cl. 10.17.3.
Power Distribution Module, Field Device Power Output	Supervised. Single open or ground-fault per ANSI/NFPA 72, Cl. 10.17.1.
Power Distribution Module, Local Field Device Power Output	Unsupervised per ANSI/NFPA 72, Cl. 10.17.1, Exception #10.17.1.8 & #10.17.1.9.
Power Supply Monitor, Input Power	Supervised. Loss of power per ANSI/NFPA 72, Cl. 10.17.3.
Power Supply Monitor, Output Power	Supervised (via Controller for opens). Single open or ground-fault per ANSI/NFPA 72, Cl. 10.17.1.
Power Supply Monitor, Charger	Supervised. Loss of charger per NFPA Cl. 10.5.9.6.
Power Supply Monitor, Battery	Supervised. Loss of battery per NFPA Cl. 10.17.3.
Controller, Digital Input	Unsupervised per ANSI/NFPA 72, Cl. 10.17.1, Exception #10.17.1.8 & #10.17.1.9.
Controller, Relay Output	Unsupervised per ANSI/NFPA 72, Cl. 10.17.1, Exception #10.17.1.8 & #10.17.1.9.
Controller, Trouble Relay Output	Unsupervised per ANSI/NFPA 72, Cl. 10.17.1, Exception #10.17.1.8 & #10.17.1.9.
Controller, 232 Expansion Output (SIL or Non-SIL)	Unsupervised per ANSI/NFPA 72, Cl. 10.17.1, Exception #10.17.1.8 & #10.17.1.9.
Controller, Ethernet Expansion Output (SIL or Non-SIL)	Unsupervised per ANSI/NFPA 72, Cl. 10.17.1, Exception #10.17.1.8 & #10.17.1.9.
Controller, SLC485 Expansion Output, including optional fiber optic equipment (SIL or Non-SIL)	Class B (Single Channel Single-Mode Fiber) Class X (Multi-Mode Fiber or Dual Channel Single-Mode Fiber or Dual Channel Wire)
Redundant Controller Connector, RS-232 (SIL or Non-SIL)	Unsupervised per ANSI/NFPA 72, Cl. 10.17.1, Exception #10.17.1.8 & #10.17.1.9.
Relay Module, Output	Unsupervised, for connection with ancillary equipment only.
Enhanced Discrete I/O, Input (software configurable, SIL or Non-SIL)	Unsupervised per ANSI/NFPA 72, Cl. 10.17.1, Exception #10.17.1.8 & #10.17.1.9.
	Initiating Device Circuit (IDC): Class A or Class B
Enhanced Discrete I/O, Output (software configurable, SIL or Non-SIL)	Unsupervised per ANSI/NFPA 72, Cl. 10.17.1, Exception #10.17.1.8 & #10.17.1.9.
	Notification Appliance Circuit (NAC): Class A or Class B
	Supervised Solenoids (Class A or Class B): Single open or ground-fault per ANSI/NFPA 72, Cl. 10.17.1. Group B: ASCO T8210A107 Group D: ASCO 8210G207 Group E: Skinner 73218BN4UNLVNOC111C2 Group F: Skinner 73212BN4TNLVNOC322C2 Group G: Skinner 71395SN2ENJ1NOH111C2 Group H: Viking 11601

Table A-1—Circuit Classifications-Continued

Signaling Path	NFPA 72: 2010 Supervision
Discrete I/O, Input (software configurable)	Unsupervised per ANSI/NFPA 72, Cl. 10.17.1, Exception #10.17.1.8 & #10.17.1.9.
	Initiating Device Circuit (IDC): Class B
Discrete I/O, Output (software configurable)	Unsupervised per ANSI/NFPA 72, Cl. 10.17.1, Exception #10.17.1.8 & #10.17.1.9.
	Notification Appliance Circuit (NAC): Class B
	Supervised Solenoids: Single open or ground-fault per ANSI/NFPA 72, Cl. 10.17.1. Group B: ASCO T8210A107 Group D: ASCO 8210G207 Group E: Skinner 73218BN4UNLVNOC111C2 Group F: Skinner 73212BN4TNLVNOC322C2 Group G: Skinner 71395SN2ENJ1NOH111C2 Group H: Viking 11601
Analog Input Module (SIL or Non-SIL)	Initiating Device Circuit (IDC): Class B
IDC Input	Initiating Device Circuit (IDC): Class B
IDCGF Input (Channel 2 only)	Unsupervised per ANSI/NFPA 72, Cl. 10.17.1, Exception #10.17.1.8 & #10.17.1.9.
SAM Output ARM Output	Notification Appliance Circuit (NAC): Class B
	Supervised Solenoids: Single open or ground-fault per ANSI/NFPA 72, Cl. 10.17.1 Group B: ASCO T8210A107 Group D: ASCO 8210G207 Group E: Skinner 73218BN4UNLVNOC111C2 Group F: Skinner 73212BN4TNLVNOC322C2 Group G: Skinner 71395SN2ENJ1NOH111C2 Group H: Viking 11601
ASH Loop (Smoke & Heat Loop)	Signaling Line Circuit (SLC): Class A or Class B (single spur)
ASH Loop (Smoke & Heat Loop) with Isolators	Signaling Line Circuit (SLC): Class X
ASH Loop (Smoke & Heat Loop) with Isolators	Signaling Line Circuit (SLC): Class B (single spur)
ASH - Addressable Smoke and Heat Module Input (software configurable)	Unsupervised per ANSI/NFPA 72, Cl. 10.17.1, Exception #10.17.1.8 & #10.17.1.9.
	Initiating Device Circuit (IDC): Class A
ASH - Addressable Smoke and Heat Module Input - Smoke detector inputs	Initiating Device Circuit (IDC): Class A (Apollo)
ASH - Addressable Smoke and Heat Module Output (software configurable)	Unsupervised per ANSI/NFPA 72, Cl. 10.17.1, Exception #10.17.1.8 & #10.17.1.9.
	Notification Appliance Circuit (Apollo): Class A

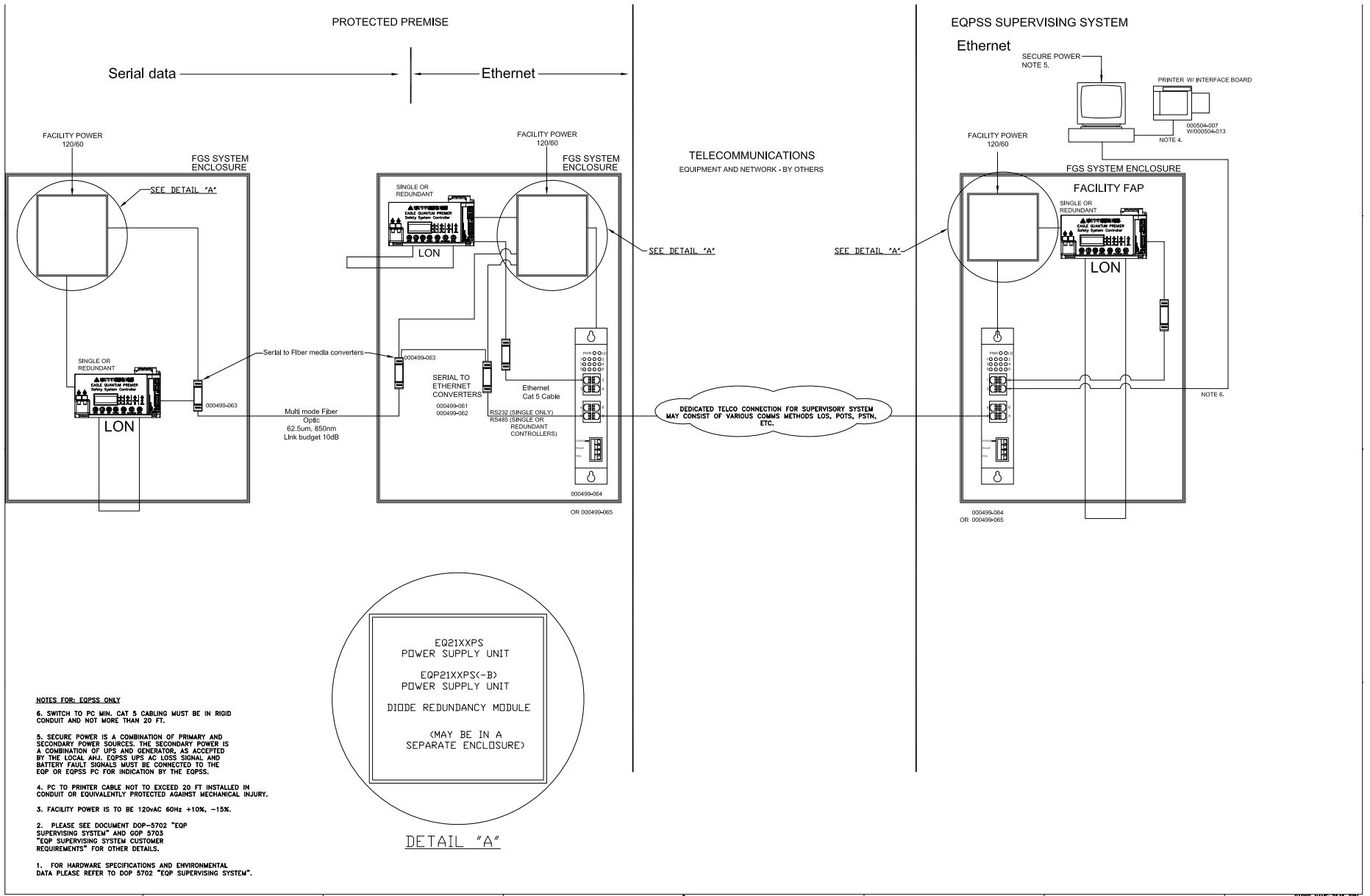

CADD NAME: 7545-32V

Figure A-2 (System Drawing 007545-001)

APPENDIX B

CSA INTERNATIONAL CERTIFICATION DESCRIPTION

HAZARDOUS LOCATIONS

- Refer to Figures B-1 and B-2 for System Classification details.
- EQxxxxEM versions rated Class I, Div. 2, Groups A, B, C, D (T4A).

GAS DETECTION

- Combustible Gas Performance verified for 0 to 100% LFL methane-in-air atmospheres per CSA C22.2 No. 152. Accuracy: $\pm 3\%$ LFL from 0 to 50% LFL, $\pm 5\%$ LFL from 51% to 100% LFL. For the Model PIRECL, refer to the PIRECL manual (form number 95-8526) for further CSA gas performance details.

NOTE: Detector Electronics combustible gas detection K factors are not CSA verified.

- Calibration of the devices has been CSA verified using the respective EQ22xxDCU, EQ22xxDCUJEX and PIRECL Series with the Det-Tronics 225130-001 (50% LFL methane) and 227115-001 H₂S Calibration Kits.
- The EQ22xxDCU Series can be used with any CSA Certified 4-20 ma device.

NOTE

CSA Certification of the 4-20 ma input does not include or imply approval of the gas detection apparatus such as sensors, transmitters, or devices connected to the system. In order to maintain CSA Certification of the system, all 4-20 ma gas detection instruments connected to the input must also be CSA Certified.

NOTE

CSA Certification allows the presence and operation of serial/Ethernet communications software in the Controller (MODBUS TCP/IP, Allen Bradley protocols, etc.); however, the communications functions are not included in the Certification.

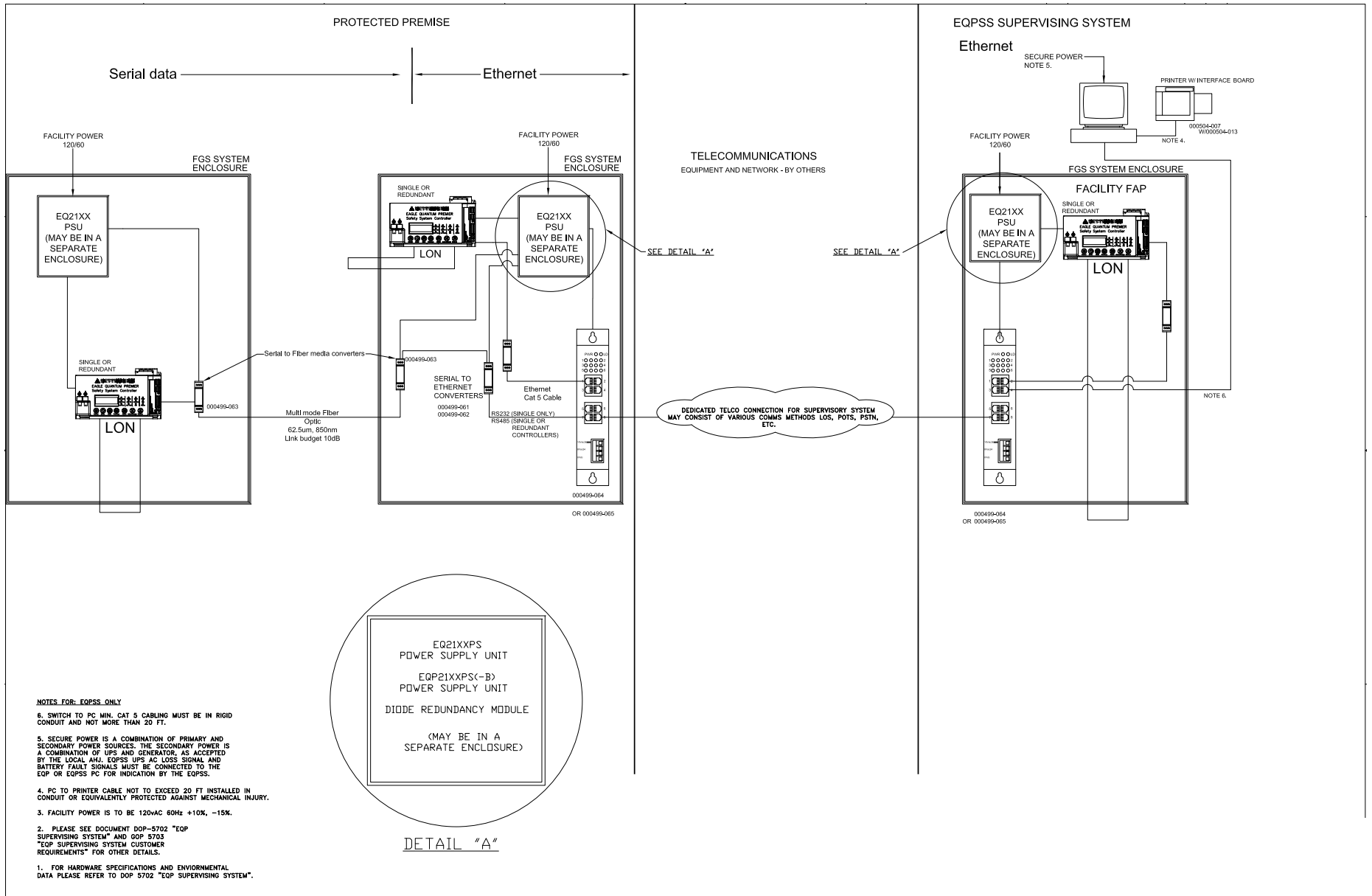

Figure B-2 (Drawing 007546-001)

APPENDIX C

ATEX AND IECEX CERTIFICATION

ATEX AND IECEX CERTIFICATION DETAILS

The Eagle Quantum Premier Fire and Gas Detection / Releasing System was tested and certified to hazardous location and combustible gas performance standards. Refer to Figure C-1 for system classification details.

The ATEX/IECEX certified Eagle Quantum Premier System field devices EQ22..., EQ24... and EQ25... are in compliance with the following standards:

- IEC 60079-0: 2011
- EN 60079-0: 2012
- IEC/EN 60079-1: 2010
- EN 60079-29-1: 2007
- EN 60079-29-4: 2010 (EQ3XXX Only)

The ATEX/IECEX certified Ex n modules of the EQP system are in compliance with the following standards:

- IEC 60079-0: 2011
- EN 60079-0: 2012
- IEC/EN 60079-15: 2010
- EN 60079-29-1: 2007
- EN 60079-29-4: 2010 (EQ3XXX Only)

For all ATEX/IECEX certified Ex n modules in the EQP system, the following Special Conditions for Safe Use apply:

The ambient temperature range is limited for EQ3XXX:

- From –40°C to +70°C if any of the output relays 1-7 (terminals 21-41) is used (energized).
- From –40°C to +80°C if all output relays 1-7 (terminals 21-41) remain open-contacted and de-energized.

For compliance to EN 60079-29-1/-4, the relevant Ex n module must be used with gas detection apparatus that are certified for compliance to EN60079-29-1/-4 and that provide a suitable linear 4-20 mA output, relay contact output or LON communication output relative to the %LFL of the available gas in the area of the gas detection apparatus. See the Manual for details on the required connection parameters.

The EQP Ex n modules shall be used in an area of no more than pollution degree 2 conforming to IEC 60664-1, and in an enclosure with a tool removable cover that complies with all relevant requirements of IEC/EN 60079-15, rated at least IP54, and shall be connected to supply circuits where the rated voltage cannot be exceeded by 40% caused by transient disturbances.

PERFORMANCE TESTING TO EN 60079-29-1: 2007 AND EN 60079-29-4: 2010

The measuring function of the EQ3XXX Controller, according to Annex II paragraph 1.5.5, 1.5.6 and 1.5.7 of the Directive 94/9/EC, was covered in this Type Examination Certificate in the following configurations:

1. Controller Model EQ3XXX with EQ3710AIM or EQ3700DCIO or EQ3730EDIO or EQ22XXDCU (tested as a stand-alone control unit with a calibrated linear 4-20mA simulator input signal or relay contacts (as applicable).
2. Controller Model EQ3XXX with EQ22xxDCUEX and STB and CGS (tested as a gas detection system with methane applied to the CGS).
3. Controller Model EQ3XXX with CTB and PIRECL (tested as a gas detection system with methane applied to the PIRECL).
4. Controller Model EQ3XXX with UD10/DCU Emulator and CGS Conditioning Board, in combination with the Det-Tronics gas sensor Model CGS (tested as a gas detection system with methane applied to the CGS).
5. Controller Model EQ3XXX with OPECL.

For the ATEX certified Eagle Quantum Premier System field devices EQ22XXDCU and EQ22XXDCUEX, the following Special Condition for Safe Use applies:

The field devices EQ22XXDCU and EQ22XXDCUEX have an ambient temperature rating for performance of -40°C to $+75^{\circ}\text{C}$.

IMPORTANT NOTE

All applied gas detectors must be ATEX certified to EN60079-29-1/-4 and the configuration must comply with the gas performance parameters stated in the Installation Manual.

APPENDIX D
EAGLE QUANTUM PREMIER SYSTEM
MARINE APPLICATIONS
U.S. COAST GUARD APPROVAL NUMBER 161.002/49/0

Approved System Description

Refer to Table D-1 for a complete list of USCG approved equipment.

Table D-1— List of Approved Equipment

Equip. No.	Manufacturer	Equipment type	Series/Model Description
1	Det-Tronics	EQ3XXX Controller	EQ3XXXP N(C) N(S) W(T)-C, panel mount only; installed inside Rittal cabinet or equivalent NEMA 12 enclosure in controlled environments; NEMA 4X enclosure for open area installations.
2	Det-Tronics	EQ3LTM LON Termination Module	Optional module used in the Controller Redundancy configuration, installed inside Rittal cabinet or equivalent NEMA 12 enclosure in controlled environments; NEMA 4X enclosure for open area installations.
3	Det-Tronics	EQ3710AIM Analog Input Module	EQ3710D(P) W, installed inside Rittal cabinet or equivalent NEMA 12 enclosure in controlled environments; NEMA 4X enclosure for open area installations.
4	Det-Tronics	EQ3720RM Relay Module	EQ3720D(P) W, installed inside Rittal cabinet or equivalent NEMA 12 enclosure in controlled environments; NEMA 4X enclosure for open area installations.
5	Det-Tronics	EQ3730EDIO Enhanced Discrete Input/Output Module	EQ3730D(P) W(T); installed inside Rittal cabinet or equivalent NEMA 12 enclosure in controlled environments; NEMA 4X enclosure for open area installations.
6	Det-Tronics	EQ3750ASH Addressable Smoke & Heat Module	EQ3750ASHP W; panel mount only, installed inside Rittal cabinet or equivalent NEMA 12 enclosure in controlled environments; NEMA 4X enclosure for open area installations.
7	Det-Tronics	EQ24xxNE Network Extender Module	EQ245(6) 3NE; Enclosure material: 5 – Aluminum, 6 –SS.
8	Det-Tronics	EQ22xxDCUEX Digital Communication Unit, Combustible	EQ225(6)3DCUEX; Enclosure material: 5 – Aluminum, 6 –SS. (Uses CGS Gas Sensor)
9	Det-Tronics	CGS Combustible Gas Sensor	CGSS1A6C2R1X (Used with the EQ22xxDCUEX)
10	Det-Tronics	PIRECLAx4 PointWatch Hydrocarbon Gas Detector	PIRECLA (1) 4 A (B) 1 (2) W (T) 1 (2)
11	Det-Tronics	PIRECLAx4 PointWatch Hydrocarbon Gas Detector "Duct Mount"	PIRECLA (1) 4 A (B) 1 (2) W (T) 1 (2); with DEC Q900C1001 Duct Mount kit
12	Det-Tronics	GT3000 Toxic Gas Detector	Model GTXS N (M) W 4 (5) Transmitter with Model GTSH2S 20P (50P,100P) Sensor or Model GTSO2 25V Sensor or Model GTSCO 100P (500P) Sensor

Table D-1— List of Approved Equipment (Continued)

Equip. No.	Manufacturer	Equipment type	Series/Model Description
13	Det-Tronics	UD10 Universal Display	UD10A (S) 5N (5M) 25 (28) W 2
14	Det-Tronics	X3301 Multispectrum Flame Detector	X3301A (S) 4N (4M) 11 (13, 14, 23) W (T) 1 (2) ; with Q9033A AI (Q9033B SS) swivel
15	Det-Tronics	X3302 Multispectrum Flame Detector	X3302A (S) 4N (4M) 11 (13, 14, 23) W 1 (2); with Q9033A AI (Q9033B SS) swivel
16	Det-Tronics	STB Sensor Termination Box	STB4 (5) A (S) 2N (2U, 3N, 5N, 6N) W (Used with the Fenwal DAF Vertical Heat Detector)
17	Det-Tronics	EQ2220GFM Ground Fault Monitor	EQ2220GFM is installed in the same enclosure with EQ3XXX Controller
18	Phoenix Contact (Germany)	EQP2120PS-B Power Supply (Discontinued)	Model Quint PS-100-240VAC/24VDC/20; panel mount only, installed in the same enclosure with EQ3XXX Controller
19	Phoenix Contact (Germany)	EQP2120PS-B Power Supply (Replacement)	Model QUINT PS-1AC/24 DC/20 panel mount only, installed in the same enclosure with EQ3XXX Controller
20	Phoenix Contact (Germany)	EQP2110PS-P Power Supply	Model QUINT PS-100-240 AC/24 DC/10EX panel mount only, installed in the same enclosure with EQ3XXX Controller
21	Phoenix Contact (Germany)	EQP2410PS-P Converter	Model QUINT PS-24 DC/24 DC/10 panel mount only, installed in the same enclosure with EQ3XXX Controller
22	Phoenix Contact (Germany)	QUINT- DIODE/40Diode Redundancy Module	Model QUINT-DIODE/40; panel mount only; installed in the same enclosure with EQ3XXX Controller and Approved Phoenix Power Supplies
23	Kidde-Fenwal (Fenwal)	DAF Vertical Heat Detector	Model 12-E27121-020-xx rated 140°F (60°C) [160°F (71°C), 190°F (88°C), 225°F (107°C)]; used with STB Sensor Termination Box, item 15
24	Fenwal	THD-7052 Heat Detector	Uses 2-wire base 2WRLT.
25	Fenwal	CPD-7054 Ionization Type Smoke Detector	Uses 2-wire base 2WRLT.
26	Fenwal	PSD-7157 and PSD-7157D Photoelectric Type Smoke Detectors	Uses 2-wire base 2WRLT.
27	Fenwal	MT-12/24-R Horn	24 V dc model; installed in Fenwal IOB-R box.
28	Fenwal	MTWP-2475W – FR Horn/Strobe	Multitone Weatherproof Horn-Strobe; installed in Fenwal IOB-R box.
29	Fenwal	Manual Call Stations Series 3300	Model 84-330001-002 pull station; uses Fenwal SGB-32S interior surface mount backbox (compatible mounting with B-11).
30	Fenwal	RA-911 Remote Indicator	Remote indicator for use with Fenwal Heat or Smoke detectors.
31	MEDC (UK)	Manual Fire Alarm Call Point PB Range	Model PB-UL-4C-6C-4-DC-D-7-R call point

Table D-1— List of Approved Equipment (Continued)

Equip. No.	Manufacturer	Equipment type	Series/Model Description
32*	Cooper Crouse Hinds	CCH ETH 2416 Horn	Uses CCH EAJC26 conduit outlet box with cover, 3/4 NPT hub size.
33	Applied Strobe Technology (Canada)	AST-4-1030 Strobe	AST-4-10-30-DC-CL-CM-75-ULC; with clear lenses
34	Air Products & Controls	SL-2000-P Duct Smoke Detector	SL-2000-P; installed in Hoffman LWC204015SS6 NEMA 4X enclosure; uses Apollo 55000-328A photoelectric head w/ RW-268A base.
35	Apollo Fire Detectors Ltd.	Discovery Ionization Smoke Detector	Apollo P/N 58000-550NA (with 4" Base Model P/N 45681-210)
36	Apollo Fire Detectors Ltd.	Discovery Optical Smoke Detector	Apollo P/N 58000-650NA (with 4" Base Model P/N 45681-210)
37	Apollo Fire Detectors Ltd.	Discovery Multisensor Detector	Apollo P/N 58000-750NA (with 4" Base Model P/N 45681-210)
38	Apollo Fire Detectors Ltd.	Discovery Heat Detector	Apollo P/N 58000-450NA (with 4" Base Model P/N 45681-210)
39	Apollo Fire Detectors Ltd.	XP95A Sounder Control Module	Apollo P/N 55000-825NA
40	Apollo Fire Detectors Ltd.	Mini Switch Monitor	Apollo P/N 55000-765NA**
41	Apollo Fire Detectors Ltd.	Priority Mini Switch Monitor	Apollo P/N 55000-765NA**

* Horn item 32 is for use in gas applications only.

** The device type depends on the priority switch setting on the device.

NA = North American Approvals

 **IMPORTANT**

The EQP2120PS-B and EQP2110PS-P Power Supplies provide EQP System devices with power from input supply 120 to 220 Vac. The EQP2120PS-B and EQP2110PS-P Power Supplies are used in pairs where primary source of input supply is connected to one and the secondary source is connected to the other. Use of these power supplies may provide the source of the secondary supply. The EQP2410PS-P Converter provides the EQP system with power from input supply 24 Vdc and provides the source if secondary supply only.

NOTE

The customer may provide other sources of the secondary supply such as secondary source batteries, their supervision or charging, or UPS. Per NFPA 72-2010 requirements, such power supply related requirements must be separately provided for and be accepted by the local Authority Having Jurisdiction (AHJ).

HAZARDOUS LOCATIONS

Refer to Figure D-1 (Drawing 007545-001) for System Classification details.

SYSTEM SPECIFICATION

EQP2120PS-B POWER SUPPLY (DISCONTINUED)—

Number of units:	16 (8 pairs) max
Input voltage:	120 – 220 Vac, -15%, +10%, 60/50 Hz single phase
Output voltage:	Nominal— 24.5 Vdc ± 1% Vdc Range— 24.5...28.0 Vdc
Input current:	Vout = 24.5 Vdc: 4.9 Amps @ 120 Vac 2.9 Amps @ 220 Vac. Vout = 28.0 Vdc: 5.6 Amps @ 120 Vac 3.2 Amps @ 220 Vac.
Output current, each:	20 A

EQP2120PS-B POWER SUPPLY (REPLACEMENT)—

Number of units:	16 (8 pairs) max
Input voltage:	120 – 220 Vac, -15%, +10%, 60/50 Hz single phase
Output voltage:	Nominal— 24.5 Vdc ± 1% Vdc Range— 24.5...28.0 Vdc
Input current:	6.6 A max @120 Vac 3.6 A max @220 Vac.
Output current, each:	20 A

EQP2110PS-P POWER SUPPLY—

Number of units:	16 (8 pairs) max
Input voltage:	120 – 220 Vac, -15% +10%, 60/50 Hz single phase
Output voltage:	Nominal— 24.5 Vdc ± 1% Vdc Range— 24.5...28.0 Vdc
Input current:	3.2 A max @120 Vac 1.7 A max @220 Vac
Output current, each:	10 A

EQP2410PS-P CONVERTER—

Number of units:	16 (8 pairs) max
Input voltage:	24 Vdc, -15%, +10%
Output voltage:	Nominal— 24.5 Vdc ± 1% Vdc Range— 24.5...28.0 Vdc
Input current:	15.7 A max @ 24 Vdc.
Output current, each:	10 A

QUINT-DIODE/40 REDUNDANCY MODULE

Number of units: 8 (2 Power Supplies can be connected to each module) max
Input voltage: 24.5...28.0 Vdc



IMPORTANT

The output voltage is adjustable. An even current distribution must be ensured by precisely setting all power supply units that are operated in parallel to the same output voltage ± 10 mV.



IMPORTANT

To ensure symmetrical current distribution it is recommended that all cable connections from all power supply units/diode redundancy modules to the power distribution bus are the same length and have the same cross section.

POWER REQUIREMENT—

Refer to Section 6 of this manual and individual device manuals for details.

NOTE

The Power Supplies, Converter, and Diode Redundancy Module electrical specifications for EQP marine applications represent a reduction in the rating range with respect to that specified by the manufacturer. The manufacturer's published electrical specifications may be viewed as reference only.

TEMPERATURE AND HUMIDITY RANGE—

See Table D-2 for details.

NOTE

The operating temperature and relative humidity specification of EQP System components including Power Supplies, Converter, and Diode Redundancy Module in EQP marine applications represent a reduction in the rating range for some components and an increase in the rating range for other components with respect to that specified by their manufacturers. The manufacturer's published operating temperature and relative humidity specifications may be viewed as reference only.

INSTALLATION—

The EQP2120PS-B Power Supply, EQP2110PS-P Power Supply, EQP2410PS-P Converter, and Diode Redundancy Module are Panel mounted and intended to be installed within the same cabinet as the EQ3XXX Controller of the EQP System. **Note: Ensure sufficient convection.** Refer to Phoenix Contact manuals as listed below for additional installation and mounting details. For other EQP System components installation, operation and maintenance refer to appropriate sections of this manual and to individual device manuals.

NOTE

SHCS # 10-24 SST screws are recommended for the Power Supply and Diode Redundancy Module panel mounting.

NOTE

Terminal End Brackets DEC P/N 000133-517 are recommended for use with EQ371(2)(3)0D (DIN rail mount) and EQ2220GFM Modules.

POWER SUPPLY SUPERVISION—

The EQP2120PS-B and EQP2110-P Power Supplies, and EQP2410PS-P Converter shall be monitored for Trouble. The power supply provides an internal relay contact DC OK signal output, floating. All power supply unit relay contacts shall be connected in series and connected to the EQ3730EDIO input. A Trouble signal will be initiated in case of a power supply failure. The Trouble signal will not identify the specific power supply unit that failed. See Figure D-2 for connecting diagram.

EQP SYSTEM MODEL 000523-009 & 000523-010

- The System consists of:
 - 1 x EQP2120PS-B Power Supply, primary
 - 2 x EQP2410PS-P Converter, secondary
 - 2 x QUINT-DIODE/40 Redundancy module
 - 1 x EQ2220GFM Ground Fault Monitor
 - 1 x EQ3XXX Controller (000523-009)
 - 0 x EQ3XXX Controller (000523-010)
 - 0 x EQ3710AIM Module & 1 x EQ3730EDIO Module (000523-009)
 - 2 x EQ3710AIM Modules & 2 x EQ3730EDIO Modules (000523-010)

- The System is mounted within 60H x 36W x 16D Stainless Steel (type 316), NRTL labeled NEMA 4X rated enclosure. The enclosure shall be lockable by key lock or padlock.

- EQP system models 000523-009 & 000523-010 are suitable for CI I, Div. 2, GRPS A, B, C & D (T4); CI I, Zone 2, GRP IIC (T4) Hazardous (Classified) Locations; Tamb = -20°C to +49°C.

- Modifications to enclosure (such as conduit entry holes, windows etc.) are permitted when implemented by the manufacturer of the enclosure.

ORDERING INFORMATION

POWER SUPPLY, DIODE, CONTROLLER, DUCT MOUNT KIT		
DEC Part Number	Model	Description
009929-001	EQP2120PS-B (Discontinued)	Phoenix Contact QUINT-PS-100-240AC/24DC/20 Panel Mount
010988-001	EQP2120PS-B (Replacement)	Phoenix Contact QUINT-PS-1AC/24DC/20 Panel Mount
010985-001	EQP2110PS-P	Phoenix Contact QUINT-PS-100-240AC/24DC/10EX Panel Mount
010892-001	EQP2410PS-P	Phoenix Contact QUINT-PS-24DC/24DC/10 Panel Mount
009934-001	Diode Redundancy Module	Phoenix Contact QUINT-DIODE/40 Panel Mount
007609-269	EQ3XXPCSW-C	EQP System Controller, panel mount
009931-001	Q900C1001	Duct Mount Kit
000523-009	000523-009	See description on page D-6
000523-010	000523-010	See description on page D-6

For other USCG Approved EQP System components, refer to Table D-1 or contact Det-Tronics Customer Service.

Refer to Section 3 of this manual for determining power requirements.

Table D-2—Temperature and Humidity Ranges

Equip. No.	Product	Temperature & RH Non-Condensing		
		Installation Category		
		Controlled environment	Installation in consoles, housings, etc.; Non-weather protected or cold locations	Weather exposed areas (Salt mist)
1*	EQ3XXX Controller with or without EQ3LTM Module	0°C to +55°C 5-95%RH	-25°C to +70°C 5-95%RH	-25°C to +70°C 5-95%RH
2*	EQ3710AIM Analog Input Module	0°C to +55°C 5-95%RH	-25°C to +70°C 5-95%RH	-25°C to +70°C 5-95%RH
3*	EQ3720RM Relay Module	0°C to +55°C 5-95%RH	-25°C to +70°C 5-95%RH	-25°C to +70°C 5-95%RH
4*	EQ3730EADIO Enhanced DiscreteInput/Output Module	0°C to +55°C 5-95%RH	-25°C to +70°C 5-95%RH	-25°C to +70°C 5-95%RH
5	EQ3750ASH	0°C to +55°C 5-95%RH	-25°C to +70°C 5-95%RH	-25°C to +70°C 5-95%RH
6	EQ24xxNE Network Extender Module	0°C to +55°C 5-95%RH	-25°C to +70°C 5-95%RH	-25°C to +70°C 5-95%RH
7	EQ22xxDCUEX Digital Communication Unit, Combustible	0°C to +55°C 5-95%RH	-25°C to +70°C 5-95%RH	-25°C to +70°C 5-95%RH
8	CGS Combustible Gas Sensor	0°C to +55°C 5-95%RH	-25°C to +70°C 5-95%RH	-25°C to +70°C 5-95%RH
9	PIRECLAx4 PointWatch Hydrocarbon Gas Detector	0°C to +55°C 5-95%RH	-25°C to +70°C 5-95%RH	-25°C to +70°C 5-95%RH
10	PIRECLAx4 PointWatch Hydrocarbon Gas Detector "Duct Mount"	0°C to +55°C 5-95%RH	-25°C to +70°C 5-95%RH	-25°C to +70°C 5-95%RH
11	GT3000 Toxic Gas Detector	0°C to +50°C 5-95%RH	-20°C to +50°C 5-95%RH	-20°C to +50°C 5-95%RH
12	UD10 Universal Display	0°C to +55°C 5-95%RH	-25°C to +70°C 5-95%RH	-25°C to +70°C 5-95%RH
13	X3301 Multispectrum Flame Detector	0°C to +55°C 5-95%RH	-25°C to +70°C 5-95%RH	-25°C to +70°C 5-95%RH
14	X3302 Multispectrum Flame Detector	0°C to +55°C 5-95%RH	-25°C to +70°C 5-95%RH	-25°C to +70°C 5-95%RH
15	STB Sensor Termination Box	0°C to +55°C 5-95%RH	-25°C to +70°C 5-95%RH	-25°C to +70°C 5-95%RH

Table D-2—Temperature and Humidity Ranges (Continued)

Equip. No.	Product	Temperature & RH Non-Condensing		
		Installation Category		
		Controlled environment	Installation in consoles, housings, etc.; Non-weather protected or cold locations	Weather exposed areas (Salt mist)
16*	EQ2220GFM Ground Fault Monitor	0°C to +55°C 5-95%RH	-25°C to +70°C 5-95%RH	-25°C to +70°C 5-95%RH
17*	EQP2120PS-B Power supply	0°C to +55°C 5-95%RH	-25°C to +55°C 5-95%RH	-25°C to +55°C 5-95%RH
18*	EQP2110PS-P Power supply	0°C to +55°C 5-95%RH	-25°C to +55°C 5-95%RH	-25°C to +55°C 5-95%RH
19*	EQP2410PS-P Converter	0°C to +55°C 5-95%RH	-25°C to +55°C 5-95%RH	-25°C to +55°C 5-95%RH
20*	QUINT-DIODE/40Diode redundancy module	0°C to +55°C 5-95%RH	-25°C to +70°C 5-95%RH	-25°C to +55°C 5-95%RH
21	DAF Vertical Heat Detector	0°C to +55°C 5-95%RH	-25°C to +70°C 5-95%RH	-25°C to +70°C 5-95%RH
22	THD-7052 Heat Detector	0°C to +55°C 5-95%RH	N/A	N/A
23	CPD-7054 Ionization Type Smoke Detector	0°C to +55°C 5-95%RH	N/A	N/A
24	PSD-7157 and PSD-7157D Photoelectric Type Smoke Detectors	0°C to +55°C 5-95%RH	N/A	N/A
25	MT-12/24-R Horn	0°C to +55°C 5-95%RH	-25°C to +70°C 5-95%RH	N/A
26	MTWP-2475W – FR Horn/Strobe	0°C to +55°C 5-95%RH	-25°C to +55°C 5-95%RH	N/A
27	Manual Call Stations Series 3300	0°C to +55°C 5-95%RH	-25°C to +70°C 5-95%RH	N/A
28	RA-911 Remote Indicator	0°C to +55°C 5-95%RH	-25°C to +70°C 5-95%RH	N/A
29	Manual Fire Alarm Call Point PB Range	0°C to +55°C 5-95%RH	-25°C to +70°C 5-95%RH	-25°C to +70°C 5-95%RH
30	CCH ETH 2416 Horn	0°C to +55°C 5-95%RH	-25°C to +70°C 5-95%RH	-25°C to +70°C 5-95%RH

Table D-2—Temperature and Humidity Ranges (Continued)

Equip. No.	Product	Temperature & RH Non-Condensing		
		Installation Category		
		Controlled environment	Installation in consoles, housings, etc.; Non-weather protected or cold locations	Weather exposed areas (Salt mist)
31	AST-4-1030 Strobe	0°C to +55°C 5-95%RH	-25°C to +70°C 5-95%RH	-25°C to +70°C 5-95%RH
32	SL-2000-P Duct Smoke Detector	0°C to +55°C 5-95%RH	0°C to +70°C 5-95%RH	0°C to +70°C 5-95%RH
33	Discovery Ionization Smoke Detector	5°C to +55°C 5-95%RH	N/A	N/A
34	Discovery Optical Smoke Detector	5°C to +55°C 5-95%RH	N/A	N/A
35	Discovery Multisensor Detector	5°C to +55°C 5-95%RH	N/A	N/A
36	Discovery Heat Detector	5°C to +55°C 5-95%RH	N/A	N/A
37	XP95A Sounder Control Module	5°C to +55°C 5-95%RH	N/A	N/A
38	Mini Switch Monitor	5°C to +55°C 5-95%RH	N/A	N/A
39	Priority Mini Switch Monitor	5°C to +55°C 5-95%RH	N/A	N/A

* For use in controlled environment, install in NEMA 12 rated enclosure or cabinet.

For use in non-weather protected, cold and salt mist exposed areas, install in NEMA 4X stainless steel enclosure or cabinet.

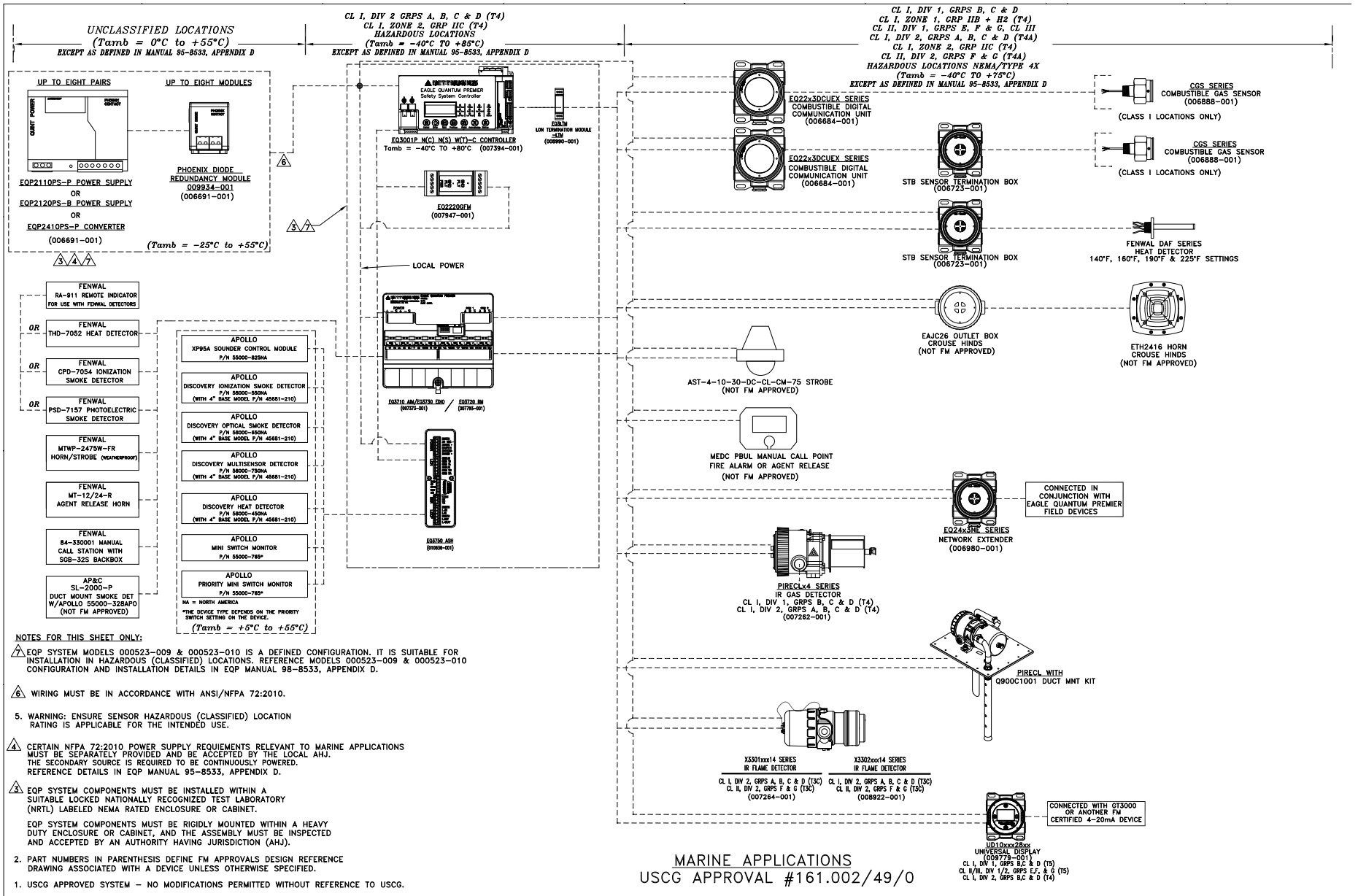
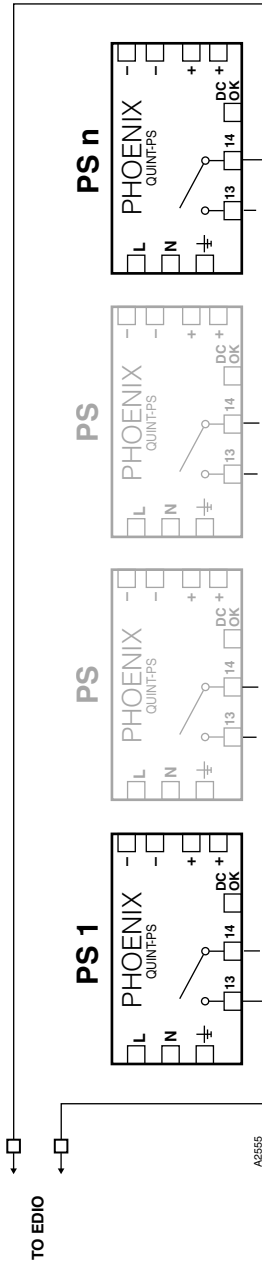

Figure D1— System Drawing 007545-001



Note: Contacts are closed during normal operation. The circuit shall be wired to an input on the EQP system (EDIO). In Logic, the selected input must be inverted and used to activate an alarm trigger gate, which initiates a fault message on the Controller and activates the fault relay output.

No supervision is necessary, since the EDIO modules must be installed in the same cabinet with EQP21X0PS and EQP2410PS.

Figure D-2—Power Supply and Converter Relays Wired in Series for Trouble Monitoring (up to 16 Power Supplies/Converters)

APPENDIX E

CE MARK

EMC DIRECTIVE 2004/108/EC DETAILS

The Eagle Quantum Premier Fire and Gas Detection/Releasing System was tested and found to be compliant with EN61000-6-2, EN61000-6-4, EN50130-4, and EN50270. The following considerations must be given for installation of the Eagle Quantum Premier system.

- For shielded cable installed in conduit, attach the wire shields to the “shield” connections on the terminal blocks, or to the earth ground on the case.
- For installations without conduit, use double shielded cable. Terminate the outer shield to the earth ground on the case. Terminate the inner shield to the “shield” connection on the terminal blocks.

ADDITIONAL DIRECTIVES

- ATEX Directive: 94/9/EC
Refer to Appendix C for details.
- Low Voltage Directive: 2006/95/EC
- WEEE Directive: 2002/96/EC

APPENDIX F

ROCKER SWITCH TABLE

Node		Rocker Switch								Node		Rocker Switch							
Address	1	2	3	4	5	6	7	8	Address	1	2	3	4	5	6	7	8		
1	X	O	O	O	O	O	O	O	61	X	O	X	X	X	X	O	O		
2	O	X	O	O	O	O	O	O	62	O	X	X	X	X	X	O	O		
3	X	X	O	O	O	O	O	O	63	X	X	X	X	X	X	O	O		
4	O	O	X	O	O	O	O	O	64	O	O	O	O	O	O	X	O		
5	X	O	X	O	O	O	O	O	65	X	O	O	O	O	O	X	O		
6	O	X	X	O	O	O	O	O	66	O	X	O	O	O	O	X	O		
7	X	X	X	O	O	O	O	O	67	X	X	O	O	O	O	X	O		
8	O	O	O	X	O	O	O	O	68	O	O	X	O	O	O	X	O		
9	X	O	O	X	O	O	O	O	69	X	O	X	O	O	O	X	O		
10	O	X	O	X	O	O	O	O	70	O	X	X	O	O	O	X	O		
11	X	X	O	X	O	O	O	O	71	X	X	X	O	O	O	X	O		
12	O	O	X	X	O	O	O	O	72	O	O	O	X	O	O	X	O		
13	X	O	X	X	O	O	O	O	73	X	O	O	X	O	O	X	O		
14	O	X	X	X	O	O	O	O	74	O	X	O	X	O	O	X	O		
15	X	X	X	X	O	O	O	O	75	X	X	O	X	O	O	X	O		
16	O	O	O	O	X	O	O	O	76	O	O	X	X	O	O	X	O		
17	X	O	O	O	X	O	O	O	77	X	O	X	X	O	O	X	O		
18	O	X	O	O	X	O	O	O	78	O	X	X	X	O	O	X	O		
19	X	X	O	O	X	O	O	O	79	X	X	X	X	O	O	X	O		
20	O	O	X	O	X	O	O	O	80	O	O	X	O	O	X	X	O		
21	X	O	X	O	X	O	O	O	81	X	O	O	O	X	O	X	O		
22	O	X	X	O	X	O	O	O	82	O	X	O	O	X	O	X	O		
23	X	X	X	O	X	O	O	O	83	X	X	O	O	X	O	X	O		
24	O	O	O	X	X	O	O	O	84	O	O	X	O	X	O	X	O		
25	X	O	O	X	X	O	O	O	85	X	O	X	O	X	O	X	O		
26	O	X	O	X	X	O	O	O	86	O	X	X	O	X	O	X	O		
27	X	X	O	X	X	O	O	O	87	X	X	X	O	X	O	X	O		
28	O	O	X	X	X	O	O	O	88	O	O	O	X	X	O	X	O		
29	X	O	X	X	X	O	O	O	89	X	O	O	X	X	O	X	O		
30	O	X	X	X	X	O	O	O	90	O	X	O	X	X	O	X	O		
31	X	X	X	X	X	O	O	O	91	X	X	O	X	X	O	X	O		
32	O	O	O	O	O	X	O	O	92	O	O	X	X	X	O	X	O		
33	X	O	O	O	O	X	O	O	93	X	O	X	X	X	O	X	O		
34	O	X	O	O	O	X	O	O	94	O	X	X	X	X	O	X	O		
35	X	X	O	O	O	X	O	O	95	X	X	X	X	X	O	X	O		
36	O	O	X	O	O	X	O	O	96	O	O	O	O	O	O	X	O		
37	X	O	X	O	O	X	O	O	97	X	O	O	O	O	X	X	O		
38	O	X	X	O	O	X	O	O	98	O	X	O	O	O	X	X	O		
39	X	X	X	O	O	X	O	O	99	X	X	O	O	O	X	X	O		
40	O	O	O	X	O	X	O	O	100	O	O	X	O	O	X	X	O		
41	X	O	O	X	O	X	O	O	101	X	O	X	O	O	X	X	O		
42	O	X	O	X	O	X	O	O	102	O	X	X	O	O	X	X	O		
43	X	X	O	X	O	X	O	O	103	X	X	X	O	O	X	X	O		
44	O	O	X	X	O	X	O	O	104	O	O	O	X	O	X	X	O		
45	X	O	X	X	O	X	O	O	105	X	O	O	X	O	X	X	O		
46	O	X	X	X	O	X	O	O	106	O	X	O	X	O	X	X	O		
47	X	X	X	X	O	X	O	O	107	X	X	O	X	O	X	X	O		
48	O	O	O	O	X	X	O	O	108	O	O	X	X	O	X	X	O		
49	X	O	O	O	X	X	O	O	109	X	O	X	X	O	X	X	O		
50	O	X	O	O	X	X	O	O	110	O	X	X	X	O	X	X	O		
51	X	X	O	O	X	X	O	O	111	X	X	X	X	O	X	X	O		
52	O	O	X	O	X	X	O	O	112	O	O	O	O	X	X	X	O		
53	X	O	X	O	X	X	O	O	113	X	O	O	O	X	X	X	O		
54	O	X	X	O	X	X	O	O	114	O	X	O	O	X	X	X	O		
55	X	X	X	O	X	X	O	O	115	X	X	O	O	X	X	X	O		
56	O	O	O	X	X	X	O	O	116	O	O	X	O	X	X	X	O		
57	X	O	O	X	X	X	O	O	117	X	O	X	O	X	X	X	O		
58	O	X	O	X	X	X	O	O	118	O	X	X	O	X	X	X	O		
59	X	X	O	X	X	X	O	O	119	X	X	X	O	X	X	X	O		
60	O	O	X	X	X	X	O	O	120	O	O	O	X	X	X	X	O		

Rocker Switch Table

Node Address	Rocker Switch								Node Address	Rocker Switch							
	1	2	3	4	5	6	7	8		1	2	3	4	5	6	7	8
121	X	O	O	X	X	X	X	O	191	X	X	X	X	X	X	O	X
122	O	X	O	X	X	X	X	O	192	O	O	O	O	O	O	X	X
123	X	X	O	X	X	X	X	O	193	X	O	O	O	O	O	X	X
124	O	O	X	X	X	X	X	O	194	O	X	O	O	O	O	X	X
125	X	O	X	X	X	X	X	O	195	X	X	O	O	O	O	X	X
126	O	X	X	X	X	X	X	O	196	O	O	X	O	O	O	X	X
127	X	X	X	X	X	X	X	O	197	X	O	X	O	O	O	X	X
128	O	O	O	O	O	O	O	X	198	O	X	X	O	O	O	X	X
129	X	O	O	O	O	O	O	X	199	X	X	X	O	O	O	X	X
130	O	X	O	O	O	O	O	X	200	O	O	O	X	O	O	X	X
131	X	X	O	O	O	O	O	X	201	X	O	O	X	O	O	X	X
132	O	O	X	O	O	O	O	X	202	O	X	O	X	O	O	X	X
133	X	O	X	O	O	O	O	X	203	X	X	O	X	O	O	X	X
134	O	X	X	O	O	O	O	X	204	O	O	X	X	O	O	X	X
135	X	X	X	O	O	O	O	X	205	X	O	X	X	O	O	X	X
136	O	O	O	X	O	O	O	X	206	O	X	X	X	O	O	X	X
137	X	O	O	X	O	O	O	X	207	X	X	X	X	O	O	X	X
138	O	X	O	X	O	O	O	X	208	O	O	O	O	X	O	X	X
139	X	X	O	X	O	O	O	X	209	X	O	O	O	X	O	X	X
140	O	O	X	X	O	O	O	X	210	O	X	O	O	X	O	X	X
141	X	O	X	X	O	O	O	X	211	X	X	O	O	X	O	X	X
142	O	X	X	X	O	O	O	X	212	O	O	X	O	X	O	X	X
143	X	X	X	X	O	O	O	X	213	X	O	X	O	X	O	X	X
144	O	O	O	O	X	O	O	X	214	O	X	X	O	X	O	X	X
145	X	O	O	O	X	O	O	X	215	X	X	X	O	X	O	X	X
146	O	X	O	O	X	O	O	X	216	O	O	O	X	X	O	X	X
147	X	X	O	O	X	O	O	X	217	X	O	O	X	X	O	X	X
148	O	O	X	O	X	O	O	X	218	O	X	O	X	X	O	X	X
149	X	O	X	O	X	O	O	X	219	X	X	O	X	X	O	X	X
150	O	X	X	O	X	O	O	X	220	O	O	X	X	X	O	X	X
151	X	X	X	O	X	O	O	X	221	X	O	X	X	X	O	X	X
152	O	O	O	X	X	O	O	X	222	O	X	X	X	X	O	X	X
153	X	O	O	X	X	O	O	X	223	X	X	X	X	X	O	X	X
154	O	X	O	X	X	O	O	X	224	O	O	O	O	O	X	X	X
155	X	X	O	X	X	O	O	X	225	X	O	O	O	O	X	X	X
156	O	O	X	X	X	O	O	X	226	O	X	O	O	O	X	X	X
157	X	O	X	X	X	O	O	X	227	X	X	O	O	O	X	X	X
158	O	X	X	X	X	O	O	X	228	O	O	X	O	O	X	X	X
159	X	X	X	X	X	O	O	X	229	X	O	X	O	O	X	X	X
160	O	O	O	O	O	X	O	X	230	O	X	X	O	O	X	X	X
161	X	O	O	O	O	X	O	X	231	X	X	X	O	O	X	X	X
162	O	X	O	O	O	X	O	X	232	O	O	O	X	O	X	X	X
163	X	X	O	O	O	X	O	X	233	X	O	O	X	O	X	X	X
164	O	O	X	O	O	X	O	X	234	O	X	O	X	O	X	X	X
165	X	O	X	O	O	X	O	X	235	X	X	O	X	O	X	X	X
166	O	X	X	O	O	X	O	X	236	O	O	X	X	O	X	X	X
167	X	X	X	O	O	X	O	X	237	X	O	X	X	O	X	X	X
168	O	O	O	X	O	X	O	X	238	O	X	X	X	O	X	X	X
169	X	O	O	X	O	X	O	X	239	X	X	X	X	O	X	X	X
170	O	X	O	X	O	X	O	X	240	O	O	O	O	X	X	X	X
171	X	X	O	X	O	X	O	X	241	X	O	O	O	X	X	X	X
172	O	O	X	X	O	X	O	X	242	O	X	O	O	X	X	X	X
173	X	O	X	X	O	X	O	X	243	X	X	O	O	X	X	X	X
174	O	X	X	X	O	X	O	X	244	O	O	X	O	X	X	X	X
175	X	X	X	X	O	X	O	X	245	X	O	X	O	X	X	X	X
176	O	O	O	O	X	X	O	X	246	O	X	X	O	X	X	X	X
177	X	O	O	O	X	X	O	X	247	X	X	X	O	X	X	X	X
178	O	X	O	O	X	X	O	X	248	O	O	O	X	X	X	X	X
179	X	X	O	O	X	X	O	X	249	X	O	O	X	X	X	X	X
180	O	O	X	O	X	X	O	X	250	O	X	O	X	X	X	X	X
181	X	O	X	O	X	X	O	X									
182	O	X	X	O	X	X	O	X									
183	X	X	X	O	X	X	O	X									
184	O	O	O	X	X	X	O	X									
185	X	O	O	X	X	X	O	X									
186	O	X	O	X	X	X	O	X									
187	X	X	O	X	X	X	O	X									
188	O	O	X	X	X	X	O	X									
189	X	O	X	X	X	X	O	X									
190	O	X	X	X	X	X	O	X									

O = OPEN / OFF
X = CLOSED / ON

APPENDIX G

DEVICE MODEL MATRICES

CONTROLLER MODEL MATRIX

MODEL	DESCRIPTION														
EQ3001	EQP Controller - 246 Nodes														
EQ3016	EQP Controller - 16 Nodes														
	<table border="1"> <thead> <tr> <th>TYPE</th> <th>MOUNTING OPTION</th> </tr> </thead> <tbody> <tr> <td>D</td> <td>Din Rail</td> </tr> <tr> <td>P</td> <td>Panel Mount</td> </tr> </tbody> </table>	TYPE	MOUNTING OPTION	D	Din Rail	P	Panel Mount								
TYPE	MOUNTING OPTION														
D	Din Rail														
P	Panel Mount														
	<table border="1"> <thead> <tr> <th>TYPE</th> <th>COM BOARD 1</th> </tr> </thead> <tbody> <tr> <td>N</td> <td>None</td> </tr> <tr> <td>C</td> <td>ControlNet</td> </tr> <tr> <td>D</td> <td>Ethernet DLR</td> </tr> </tbody> </table>	TYPE	COM BOARD 1	N	None	C	ControlNet	D	Ethernet DLR						
TYPE	COM BOARD 1														
N	None														
C	ControlNet														
D	Ethernet DLR														
	<table border="1"> <thead> <tr> <th>TYPE</th> <th>COM BOARD 2</th> </tr> </thead> <tbody> <tr> <td>N</td> <td>None</td> </tr> <tr> <td>E</td> <td>Ethernet Port Expansion</td> </tr> <tr> <td>S</td> <td>Serial Port Expansion</td> </tr> </tbody> </table>	TYPE	COM BOARD 2	N	None	E	Ethernet Port Expansion	S	Serial Port Expansion						
TYPE	COM BOARD 2														
N	None														
E	Ethernet Port Expansion														
S	Serial Port Expansion														
	<table border="1"> <thead> <tr> <th>TYPE</th> <th>APPROVALS*</th> </tr> </thead> <tbody> <tr> <td>R</td> <td>VNIPO/VNIIFTRI (Russia)</td> </tr> <tr> <td>S</td> <td>SIL</td> </tr> <tr> <td>T</td> <td>SIL/FM/CSA/ATEX/IECEX</td> </tr> <tr> <td>T-C</td> <td>T plus US Coast Guard</td> </tr> <tr> <td>W</td> <td>FM/CSA/ATEX/IECEX</td> </tr> <tr> <td>W-C</td> <td>W plus US Coast Guard</td> </tr> </tbody> </table>	TYPE	APPROVALS*	R	VNIPO/VNIIFTRI (Russia)	S	SIL	T	SIL/FM/CSA/ATEX/IECEX	T-C	T plus US Coast Guard	W	FM/CSA/ATEX/IECEX	W-C	W plus US Coast Guard
TYPE	APPROVALS*														
R	VNIPO/VNIIFTRI (Russia)														
S	SIL														
T	SIL/FM/CSA/ATEX/IECEX														
T-C	T plus US Coast Guard														
W	FM/CSA/ATEX/IECEX														
W-C	W plus US Coast Guard														

*Type "APPROVALS" can use one or more letters to designate the approvals of the product. Some configurations are not available. Check with factory for additional information.

For USCG approved controller models, refer to Appendix D.

NOTE: Contact Customer Service when ordering replacement EQ3XXX Controllers for redundant systems.

EDIO MODEL MATRIX

MODEL	DESCRIPTION										
EQ3730	8 Channel Enhanced Discrete Input/Output (EDIO) Module										
	<table border="1"> <thead> <tr> <th>TYPE</th> <th>MOUNTING OPTION</th> </tr> </thead> <tbody> <tr> <td>D</td> <td>DIN Rail</td> </tr> <tr> <td>P</td> <td>Panel</td> </tr> </tbody> </table>	TYPE	MOUNTING OPTION	D	DIN Rail	P	Panel				
TYPE	MOUNTING OPTION										
D	DIN Rail										
P	Panel										
	<table border="1"> <thead> <tr> <th>TYPE</th> <th>APPROVALS*</th> </tr> </thead> <tbody> <tr> <td>R</td> <td>VNIPO/VNIIFTRI (Russia)</td> </tr> <tr> <td>S</td> <td>SIL</td> </tr> <tr> <td>T</td> <td>SIL/FM/CSA/ATEX/IECEX</td> </tr> <tr> <td>W</td> <td>FM/CSA/ATEX*/IECEX</td> </tr> </tbody> </table>	TYPE	APPROVALS*	R	VNIPO/VNIIFTRI (Russia)	S	SIL	T	SIL/FM/CSA/ATEX/IECEX	W	FM/CSA/ATEX*/IECEX
TYPE	APPROVALS*										
R	VNIPO/VNIIFTRI (Russia)										
S	SIL										
T	SIL/FM/CSA/ATEX/IECEX										
W	FM/CSA/ATEX*/IECEX										

*Type "APPROVALS" can use one or more letters to designate the approvals of the product. Some configurations are not available. Check with factory for additional information.

DCIO MODEL MATRIX

MODEL	DESCRIPTION	
EQ3700	8 Channel Discrete Input/Output (DCIO) Module	
	TYPE	MOUNTING OPTION
	D	DIN Rail
	P	Panel
	TYPE	APPROVALS*
R	VNIPO/VNIIFTRI (Russia)	
W	FM/CSA/ATEX/IECEX	

*Type "APPROVALS" can use one or more letters to designate the approvals of the product. Some configurations are not available. Check with factory for additional information.

AIM MODEL MATRIX

MODEL	DESCRIPTION	
EQ3710	8 Channel Analog Input (AIM) Module	
	TYPE	MOUNTING OPTION
	D	Din Rail
	P	Panel
	TYPE	APPROVALS*
	R	VNIPO/VNIIFTRI (Russia)
	S	SIL
T	SIL/FM/CSA/ATEX/IECEX	
W	FM/CSA/ATEX/IECEX	

*Type "APPROVALS" can use one or more letters to designate the approvals of the product. Some configurations are not available. Check with factory for additional information.

RELAY MODULE MODEL MATRIX

MODEL	DESCRIPTION	
EQ3720	8 Channel Relay Module (RM)	
	TYPE	MOUNTING OPTION
	D	Din Rail
	P	Panel
	TYPE	APPROVALS*
R	VNIPO/VNIIFTRI (Russia)	
W	FM/CSA/ATEX/IECEX	

*Type "APPROVALS" can use one or more letters to designate the approvals of the product. Some configurations are not available. Check with factory for additional information.



95-8533



FlexSonic® Acoustic
Leak Detector



X3301 Multispectrum
IR Flame Detector



PointWatch Eclipse® IR
Combustible Gas Detector



FlexVu® Universal Display
with GT3000 Toxic Gas Detector



Eagle Quantum Premier®
Safety System

Corporate Office
6901 West 110th Street
Minneapolis, MN 55438 USA
www.det-tronics.com

Phone: 952.946.6491
Toll-free: 800.765.3473
Fax: 952.829.8750
det-tronics@det-tronics.com

All trademarks are the property of their respective owners.
© 2014 Detector Electronics Corporation. All rights reserved.

Det-Tronics manufacturing system is certified to ISO 9001—
the world's most recognized quality management standard.

