

# EXPANSION JOINTS PRODUCTS

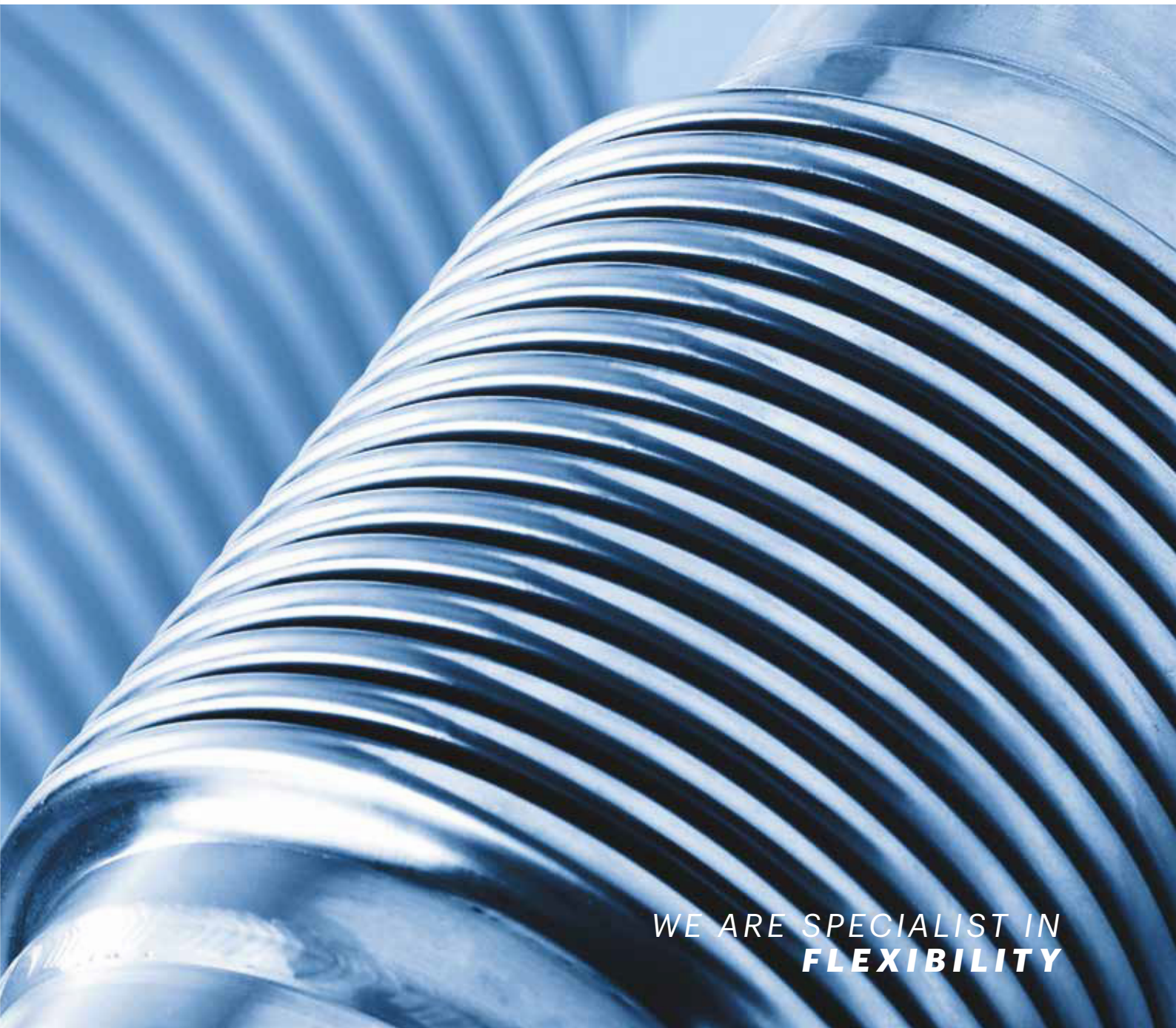

WE ARE SPECIALIST IN  
**FLEXIBILITY**





## THE COMPANY

Ayvaz holds the production experience of flexible connection parts at various types and customized designs for the industry for seven decades.

The reputation of our company remains high thanks to our capability of providing innovative and reliable solutions for our cooperators.

We work day and night to make our partners feel close to our expertise of "flexible solutions" wherever their businesses are located.

## CONSULTING

We offer a wide range of products for all possible industries. We also provide engineering activities from product specification to project estimation and work on to provide the most specific solution for each case.

We delightfully share our expertise with the potential clients who experience problems with calculation for piping systems and product selection in new plants.





## Customer Relations

In order to locate ourselves close to the customers, Ayvaz opens new offices all around the world and employs local individuals who are trained at our competence center in Istanbul. These individuals play a key role to maintain our vision of "think global, be local".

Pre-sales operations enable our sales team to identify and analyze customer needs and problems.

We very much value gathering the feedbacks and suggestions of the customers in order to develop ourselves and our communication skills.



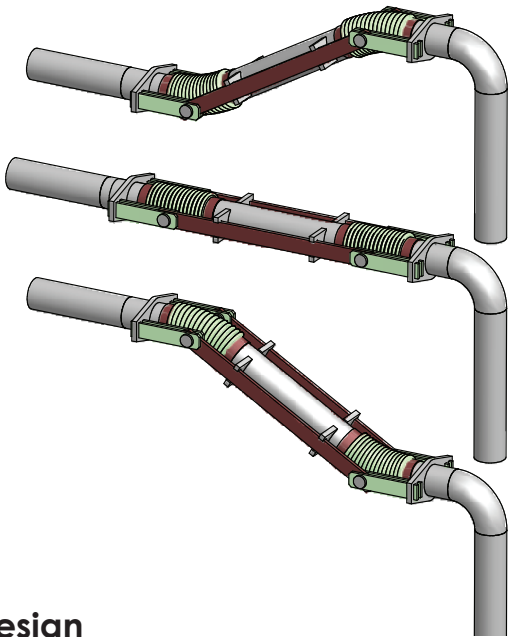

## Design and Product Selection

Expansion joint and pipeline designs are critical in order to build up firm affective pipelines with maximum life. Ayvaz provides all required calculations in order to define the thermal expansion amount and the stress occurred accordingly.

These calculated values are used at design process of our expansion joints to provide most reliable solution.

At Ayvaz we use EJMA 10th edition design software for expansion joints also provides all necessary data for the expansion joints also the forces to be conducted to pipe supports for appropriate pipe support designs.

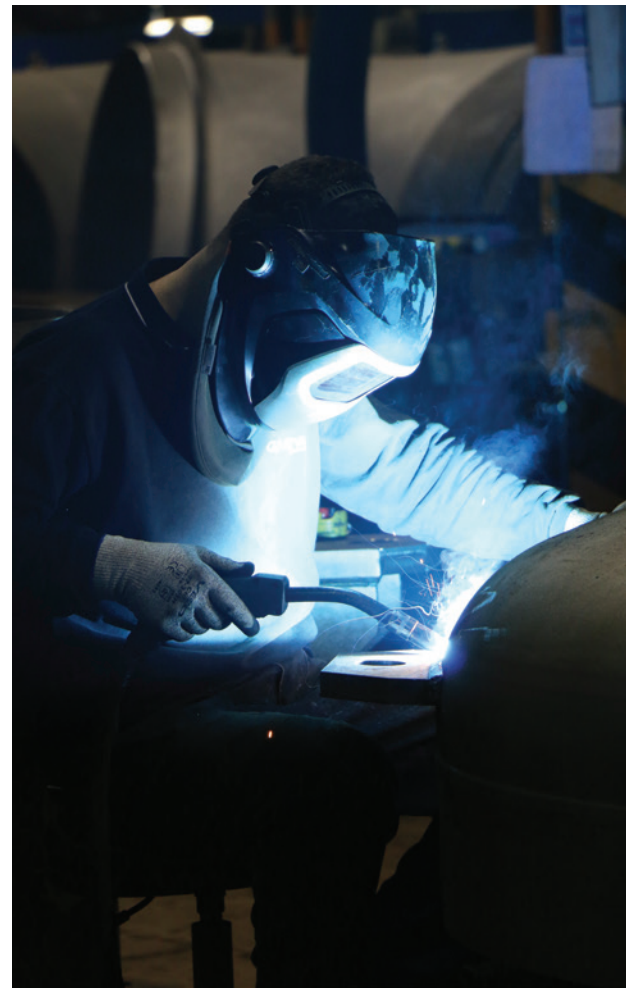

## Production

Ayvaz is the first metal bellowed expansion joint manufacturer of Turkey and one of the biggest ones in Europe.

The company has started expansion joint production in 1975 and been developing the product range of expansion joints for all industrial requirements since then.

We keep up with the state of art technology production techniques and train our employees as to use and control these techniques individually.

We are able to produce metal bellowed expansion joints at the sizes from DN25 up to DN5000 and flexible metal hoses at the sizes from DN6 up to DN300. We can also design and produce bigger expansion joints for any special purpose on the demand of any industry.





## RELIABILITY IN EACH STAGE

### Quality

We aim to provide products to work with maximum service life for any operating condition. We constantly apply various tests on our goods to maintain the highest quality possible accordingly.

Ayvaz has a TÜV accredited testing laboratory that we can make following tests in our production facility.

- Pressure resistance
- NDT Tests
- Elongation
- Fatigue, Safety
- Impact Test
- Salt Spray Test
- Micro Welding Control
- 3D Dimensional Control

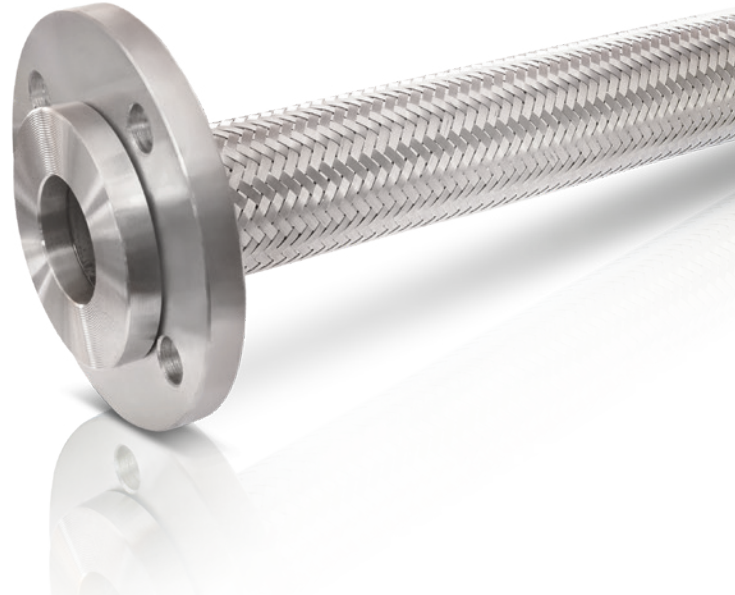

### Certification

As being the leader of installation sector, Ayvaz operates its production complying with the standards that recognized by the most important national and international bodies and industrial associations.



This philosophy brings benefit to the users as well as helps to improve general quality and harmony at expansion joint and flexible metal hose applications.



# CERTIFICATE

**Certificate registration number: ZSTS/SWZE/2460**

The notified body  
TÜV AUSTRIA SERVICES GMBH (identification number 0408)  
certifies, that the manufacturer

**HACI AYYAZ ENDÜSTRİYEL MAMÜLLER SAN VE TIC A.Ş**  
Hadımköy Mh. Mustafa Inan cd.no.44 Arnavutköy – İstanbul Türkiye

operates a quality assurance system for design, manufacture, final inspection and testing according to Annex III of the Pressure Equipment Directive 2014/68/EU which is subject to surveillance by TÜV AUSTRIA SERVICES GmbH and is therefore authorized to apply the following conformity assessment procedures according Pressure Equipment Directive 2014/68/EU:

**Modules E, E1, D, D1, H and H1**

**Scope: Axial , Lateral, Angular, Universal, Externally Pressurized and Pressure Balanced Expansion Joints from DN12 to DN6000, Bellows from DN12 to DN6000; Rectangular / Square Expansion Joints 100mmX100mm - 6000mmX6000mm**

Based on our audit carried out on July 14, 2021 in accordance with Annex III of the Pressure Equipment Directive 2014/68/EU we certify compliance with the requirements.

Results of the audit are recorded in the audit report  
21-IS-1056-2021-PED-MODUL H-026 dated July 14, 2021.

Pressure equipment and assemblies within the scope of this certificate shall carry the marking as illustrated:

**CE 0408**

This certificate is valid from November 19, 2021 to November 18, 2024 provided that the terms and conditions of the agreement with the notified body are met.

ZERTIFIKAT | CERTIFICATE | CERTIFICAT | CERTIFICADO | СЕРТИФИКАТ | شهادة | 证书 | 인증서



Vienna, 19.11.2021

*M. Schwarz*

DI Martin Schwarz

**Notified Body 0408  
TÜV AUSTRIA SERVICES GMBH**





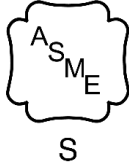

## CERTIFICATE OF AUTHORIZATION

The named company is authorized by The American Society of Mechanical Engineers (ASME) for the scope of activity shown below in accordance with the applicable rules of the ASME Boiler and Pressure Vessel Code. The use of the ASME Single Certification Mark and the authority granted by this Certificate of Authorization are subject to the provisions of the agreement set forth in the application. Any construction stamped with the ASME Single Certification Mark shall have been built strictly in accordance with the provisions of the ASME Boiler and Pressure Vessel Code.

COMPANY:

**HACI AYVAZ ENDUSTRIYEL MAMULLER SAN. VE TIC. A.S.**  
Hadımköy Mh. Mustafa İnan Cad. No:44 Arnavutköy  
Istanbul 34555  
Turkey

SCOPE:

**Manufacture and assembly of power boilers at the above location and field sites controlled by the above location**

AUTHORIZED: **August 29, 2022**

EXPIRES: **August 29, 2025**

CERTIFICATE NUMBER: **58187**

Board Chair, Conformity Assessment

Managing Director, Standards & Engineering Services

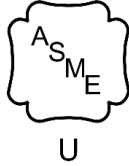

## CERTIFICATE OF AUTHORIZATION

The named company is authorized by The American Society of Mechanical Engineers (ASME) for the scope of activity shown below in accordance with the applicable rules of the ASME Boiler and Pressure Vessel Code. The use of the ASME Single Certification Mark and the authority granted by this Certificate of Authorization are subject to the provisions of the agreement set forth in the application. Any construction stamped with the ASME Single Certification Mark shall have been built strictly in accordance with the provisions of the ASME Boiler and Pressure Vessel Code.

COMPANY:

**HACI AYVAZ ENDUSTRIYEL MAMULLER SAN. VE TIC. A.S.**  
Hadımköy Mh. Mustafa İnan Cad. No:44 Arnavutköy  
Istanbul 34555  
Turkey

SCOPE:

**Manufacture of pressure vessels at the above location and field sites controlled by the above location (This authorization does not cover impregnated graphite)**

AUTHORIZED: **August 29, 2022**

EXPIRES: **August 29, 2025**

CERTIFICATE NUMBER: **58188**

Board Chair, Conformity Assessment

Managing Director, Standards & Engineering Services



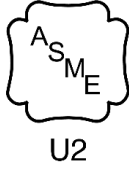

## CERTIFICATE OF AUTHORIZATION

The named company is authorized by The American Society of Mechanical Engineers (ASME) for the scope of activity shown below in accordance with the applicable rules of the ASME Boiler and Pressure Vessel Code. The use of the ASME Single Certification Mark and the authority granted by this Certificate of Authorization are subject to the provisions of the agreement set forth in the application. Any construction stamped with the ASME Single Certification Mark shall have been built strictly in accordance with the provisions of the ASME Boiler and Pressure Vessel Code.

COMPANY:

**HACI AYVAZ ENDUSTRIYEL MAMULLER SAN. VE TIC. A.S.**  
Hadımkoş Mh. Mustafa İnan Cad. No:44 Arnavutköy  
Istanbul 34555  
Turkey

SCOPE:

**Manufacture of Class 1 and Class 2 pressure vessels at the above location and field sites controlled by the above location**

AUTHORIZED: **August 29, 2022**

EXPIRES: **August 29, 2025**

CERTIFICATE NUMBER: **58189**

A handwritten signature in black ink, appearing to read 'Richard D. Caplan'.

Board Chair, Conformity Assessment

A handwritten signature in black ink, appearing to read 'L.M. Zusinberg'.

Managing Director, Standards & Engineering Services



## EXPANSION JOINTS



One of the basic rules of physics is materials to expand and compress caused by the temperature changes. Expansion joints are the elements that absorb all those expansions, compressions and also vibrations and let the industrial systems work continuously and efficiently.

Ayvaz metal bellowed expansion joints are designed and built using the latest CAD and production techniques. The main usage area of expansion joints are the pipeline applications. Our expansion joints are constantly used to meet the such needs of industry;

- Safe operation
- Temperature and pressure resistance
- Easy assembly through flexibility
- Reliable connection
- Vacuum resistance
- Great service life and condition

**Ayvaz is one of the biggest metal bellowed expansion joint manufacturers of Europe and the member of AEQ.**

Our calculations are based on DIN EN 14917, EJMA, PED2014/68/EU, ASME Sec. VIII Div.1, Div.2 & ASME B31.3 definitions.

### Purpose of Metal Bellowed Expansion Joints

Steel expansion joints are mainly used in appliances, machines, piping systems, pump outlet mechanism where the installation and maintenance space is limited. They are preferred to;

- Compensate the movement in specific direction
- Compensate the expansion and compression
- Reduce stress
- Prevent noise and oscillation transmission
- Compensate for ground and foundation settlement
- Eliminate the installation inaccuracies







## EXPANSION JOINTS

### Types of Metal Bellowed Expansion Joints

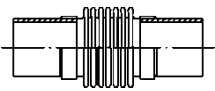
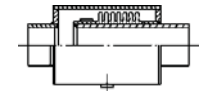
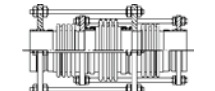
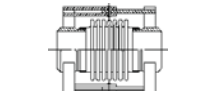
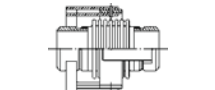
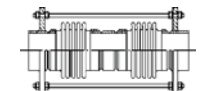
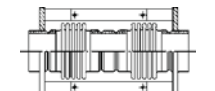
Expansion joints can be classified under three groups according to the types of movement to be absorbed.

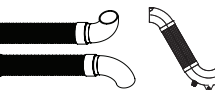
1. Axial Expansion Joints
2. Lateral Expansion Joints
3. Angular Expansion Joints

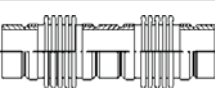
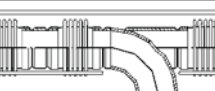
Type	Design	Pressure thrust restraint	Movement					
			Axial	Angular		Lateral		
				Single plane	Multi plane	Single plane	Multi plane	
AXIAL	Internally pressurised		No	Yes	Limited	Limited	Limited	Limited
	Externally pressurised		No	Yes	Limited	Limited	Limited	Limited
	In-line pressure balanced		Yes	Yes	No	No	No	No
ANGULAR	Hinge		Yes	No	Yes	No	No	No
	Gimbal		Yes	No	Yes	Yes	No	No
LATERAL	Two tie-bars spherical		Yes	No	Yes	No	Yes	Yes
	Two tie-bars Pinned (plane)		Yes	No	No	No	Yes	No
	Double gimbal		Yes	No	Yes	Yes	Yes	Yes
FIRE PROTECTION	Double gimbal for Fire Protection (FM approved)		No	Yes	Yes	Yes	Yes	Yes
	Loop Joints (FM approved)		Yes	Yes	Yes	Yes	Yes	Yes
UNIVERSAL	Unrestrained One or two bellows		No	Yes	Yes	Yes	Yes	Yes
			No	Yes	Yes	Yes	Yes	Yes
	Elbow Pressure balanced		Yes	Yes	Yes with two tie rods only	No	Yes	Yes

## EXPANSION JOINTS

### GENERAL

Use of expansion joints is necessary for almost all industrial applications in modern days. In order to make sure those industrial plants to work efficiently and reliably, expansion joints must fulfill following tasks;

- \*Compensation of thermal movements in pipelines.
- \*Absorption of equipment vibrations from the assembled systems
- \*Isolation of the seismic movements or building settlements for protection.
- \*Noise reduction
- \*Reduction of forces and moments at assemblies

### RANGE

The complete range of the products can be divided into two sections.

- 1-Standard expansion joints.
- 2-Specially designed expansion joints

### STANDARD EXPANSION JOINTS

Nominal Diameters: DN15-DN5000

Nominal Pressures: PN1-PN63

Connections: Weld Ends acc. to ISO  
Flanges acc. to DIN EN 1092/1

Materials: Material selection according to application temperature and fluid is to be done acc. to below table

Temperature Range °C	Materials for Standard Range		
	Bellow	Weld Ends	Flanges
-10 to 300**	1.4541 (AISI321)	St 37.2	St 37.2
310 to 500	1.4541 (AISI321)	P265GH/355GH	P265GH/355GH
510 to 600	1.4541 (AISI321)	1.4301 (AISI304)	1.4301 (AISI304)
610 to 900	Nickel Alloys	Nickel Alloys	Nickel Alloys

\*\*The limit temperature for the low pressure range is 300 °C

Temperature Range °C	Reduction Factor Kp	Bellow Material	
20	1,00	1,4541 AISI 321	
100	0,85		
150	0,81		
200	0,77		
250	0,71		
300	0,68		
350	0,64		
400	0,63		
450	0,62		
500	0,60		
550	0,59		
600	0,57		
650	0,37		Incoloy 800H
700	0,24		
750	0,15		
800	0,10		
850	0,05		
900	0,02		

### Nominal Pressure PN

Standard expansion joints are designed according to the nominal pressure (PN) classifications and given in the dimension tables by standard PN rating (PN16)

Given pressure rating corresponds to the permissible operating gauge pressure at room temperature. It is well known that permissible pressure at elevated temperature is lower than the nominal pressure. Due to the reduced strength characteristic values of the materials used, permissible pressure must be calculated and considered this way.

### Kp Reduction Factor

$$Kp = Rpv / RpRT$$

Strength Characteristics value (Yield point)

RpV = @Temperature N/mm<sup>2</sup>

RpRT = @Room temperature N/mm



## SPECIAL DESIGNED EXPANSION JOINTS

### SPECIAL DESIGNS

Bellows of special expansion joints are designed according to EJMA code. For high pressure applications multi layered bellows also bellows with reinforcing and equalizing rings are possible

According to the requested features like type of transported media, spring rate values (axial, lateral, angular) or operation temperature, pressure & life cycle bellows material could be customized.

### Design&Construction

General construction standard is EN14917:2012  
 EJMA, bellows design code  
 EN13445 unfired pressure vessels  
 EN13480 metallic industrial piping

ASME Sec. VIII Div.1 & Div.2  
 ASME B31.3

All welding operations for the construction of expansion joints are completed according to European&ASME Norms.  
 WPS EN ISO 15609-1  
 WPQR EN ISO 15614-1  
 Welders Certificate EN ISO 9606-1  
 Welding Operators EN ISO 14732  
 ASME Sec IX

### Test&Certification

- Expansion Joints are the parts of piping system of pressurized equipment in this respect construction of the expansion joints are designed and produced according to PED 2014/68/EU&ASME U Stamp-U2 Stamp.
- Expansion joints are exposed to hydrostatic pressure at 1,5 times of design pressure.
- For full vacuum applications, vacuum test at 760 Hg/mm is also applicable.
- Additionally, gas leakage detection with helium is advised for proper tightness.

### NDT Controls

Non-destructive testing for welding controls are completed in house by the TÜV accredited third party inspectors. Following controls and standards are applicable, NDT Controls acc. to ASME Sec. IX is also applicable.

Weld Type	NDT Method	Application Standard	Acceptance Criteria	Application By
Butt Welds	RT or UT	RT- EN ISO 17636	EN RT-EN ISO 10675-1, Lev.1	EN ISO 9712 min. Level II
		UT - EN ISO 17640	EN ISO 11666	
			EN ISO 22825	
Fillet Welds	PT or MT	PT - EN ISO 3452-1	EN ISO 23277 Lev. 1	
		MT- EN ISO 17638	EN ISO 23278	
All Welds	VT	VT - EN ISO 17637	EN ISO 5817 Lev B	

### PRESSURE BALANCED EXPANSION JOINTS

A pressure balanced expansion joint is used to accommodate and counteract the bellows pressure thrust. An additional bellows joins to the construction to incorporate into the unit and is subject to the line pressure to generate a force equal and opposite to that on the main bellows. Connecting all these bellows together neutralizes the pressure load on the construction.

Pressure balanced expansion joints are generally installed at changes of direction in piping (elbow type) but in-line types are also available. Use of pressure balanced expansion joints helps the piping designers not to create main anchors to accommodate combined movements at the direction changing points. Limited number of manufacturers design and manufacture pressure balanced expansion joints requires a great deal of knowledge and expertise. Ayvaz is a member of this exclusive group.

## SPECIAL DESIGNED EXPANSION JOINTS

Ayvaz is able to design and produce custom design special expansion joints for any industry including power-generation and energy businesses.

Ayvaz specializes in high value-added products made from advanced stainless steel grades and special alloys for the most demanding industries.

### INDUSTRIES

- Geo-Thermal Power
- Thermoelectric power plants
- Petrochemical Plants
- Oil Refineries
- Heat Recovery Stream Generation
- Diesel Engines & Turbines

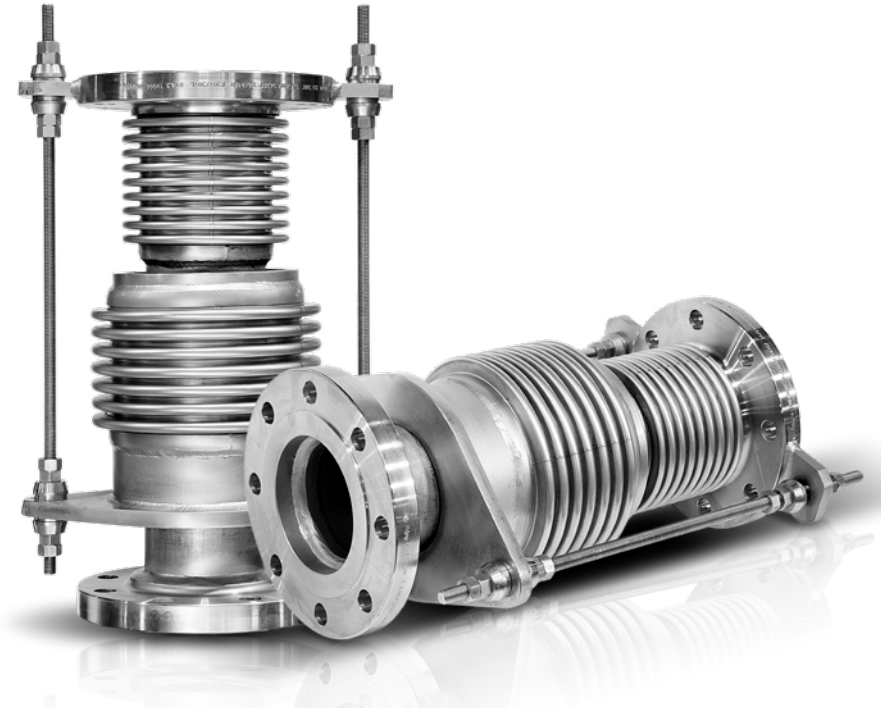

**IN-LINE PRESSURE BALANCED EXPANSION JOINTS**

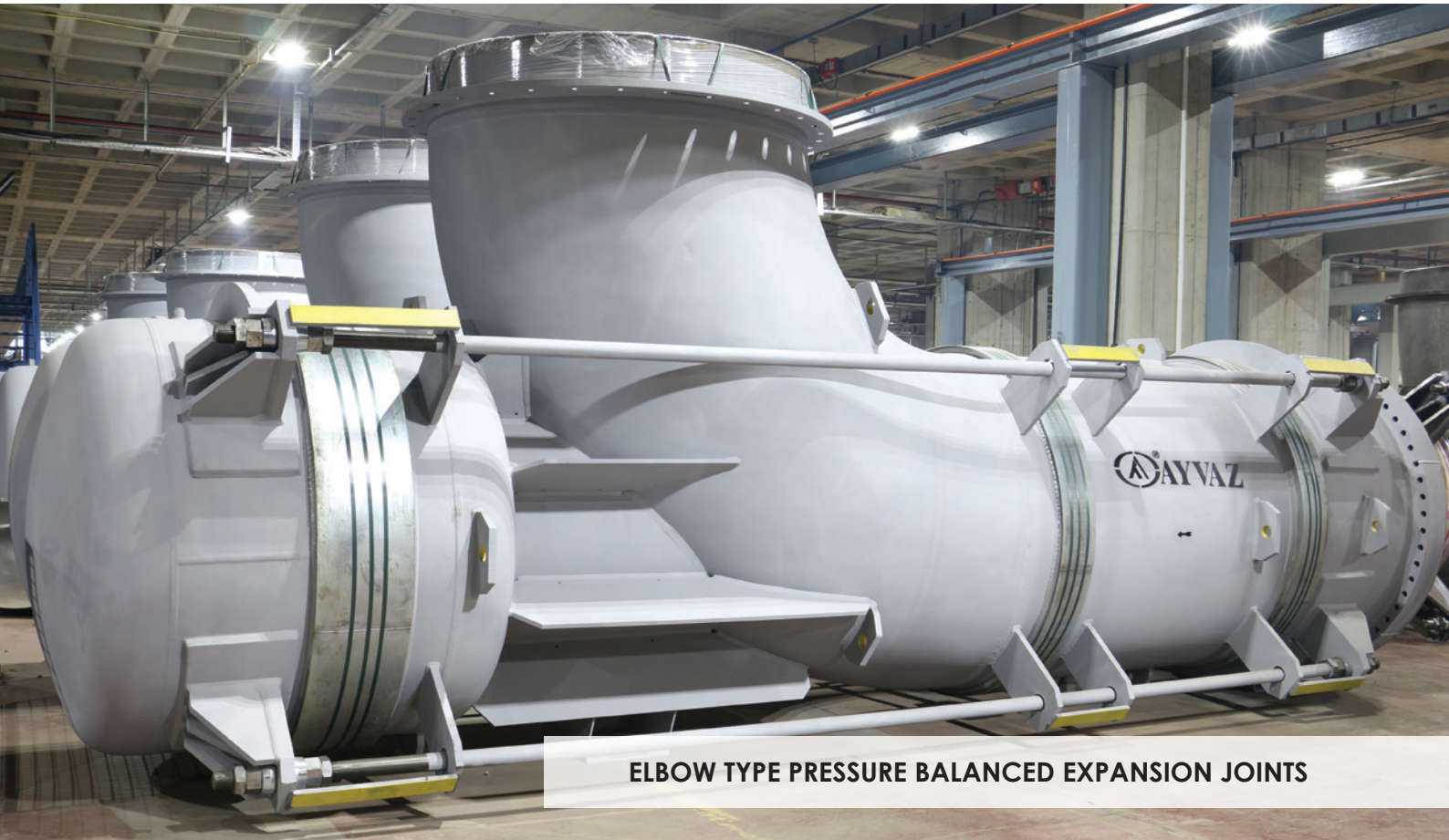

**ELBOW TYPE PRESSURE BALANCED EXPANSION JOINTS**



**SPECIAL DESIGNED EXPANSION JOINTS**

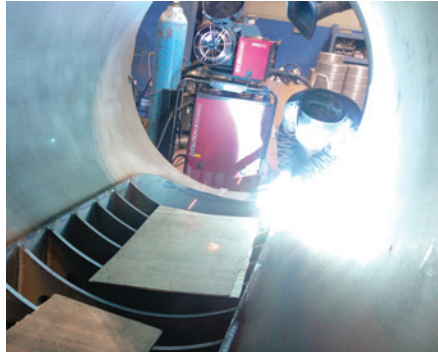



## SPECIAL DESIGNED EXPANSION JOINTS

### RECTANGULAR EXPANSION JOINTS

Rectangular expansion joints have a variety of applications in the power, petrochemical, refining, chemical and steel industries. Since there are no standard duct sizes, due to the wide range of pressure and temperature combinations, each rectangular expansion joint is custom-engineered to provide the most economical design that will absorb the thermal movements of the system in which it is installed.



### HRSG BOILER PENETRATION SEALS

Ayvaz penetration seals were developed to address many problems associated with penetrating the shell of a boiler or similar pressure casing. Penetration seal is a bellows expansion joint that offers a complete seal that eliminates the leakage of heat and other emission, reduces noise and protects maintenance personnel.

Ayvaz penetration seals are available in one piece and two pieces clamshell models to accommodate nearly any application from original manufacturers to retrofits or existing installations.



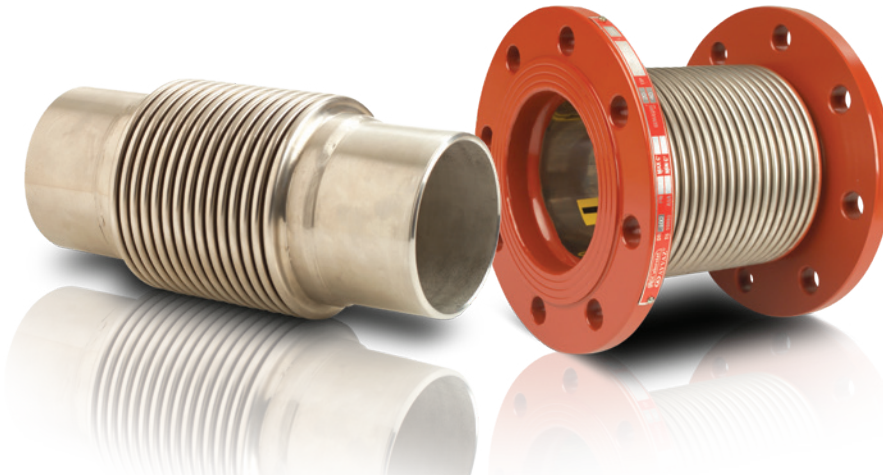

Scan this QR Code



Axial expansion joints are designed to absorb movements aligned with the pipeline axis. They are fitted in the pipeline, in line with the movement. They require an anchor each end of the system to resist the pressure force and to compress the bellows. Proper pipe alignment guides are required.

### Advantages of Axial Expansion Joints

- Bellows design according to EJMA coding system.
- Construction according to EN14917 standard.
- Easy to absorb axial movements of the pipelines.
- No direction changes of the flow.
- Minimum application area in comparison with pipe loops.
- Easy installation and maintenance.

### Application Areas

- HVAC piping lines
- Exhaust Systems
- Vibration absorption
- Industrial process & applications
- Power generation & Energy plants

### DESIGN (EN 14917&EJMA)

Bellow Material	Stainless Steel AISI 321 (Opt.304,316L,316Ti,309)
Connection Types	Fixed and Floating Flanged, Welded Ended & Grooved, Threaded
Flange Material	PN 16, St.37.2 as standard, the material can be customised on request
Inner Sleeve	Available in stainless steel AISI 321 (Opt. 304,316L,316Ti,309) on request
Accessories	Inner sleeve, cover, counter flange, gaskets, insulation etc. are available on request.
Certificates	Material certificate 3.1 according to EN 10204 and /or ASME PED 2014/68/EU Cat.III Mod.H

### Operation Conditions

Operating Temperature	-10°C/+550°C
Operating Pressure	Standard pressure rating is PN16 Can be produced with different pressure rates PN 2,5-63 PN corresponds to the allowable operating pressure at room temperature

### Important

Standard models are produced as un-restrained, fixed points should be created as to withstand springing force as well as pressure thrust caused by the system pressure. For detailed information, get in contact with Ayvaz's expert sales team. We strongly advise against the use of expansion joints and bellows for misalignment. Torsion on bellow parts are not desirable and should be eliminated.



# AXIAL EXPANSION JOINTS

## Axial Expansion Joints with 30mm expansion capacity without inner sleeve

With fixed flange			
Type	Expansion Amount	Available Sizes (DN)	Pressure Class (PN)
MKSF-30	30 mm (-20/+10)	25-5000	16

With floating flanges			
Type	Expansion Amount	Available Sizes (DN)	Pressure Class (PN)
MKDF-30	30 mm (-20/+10)	25-5000	16

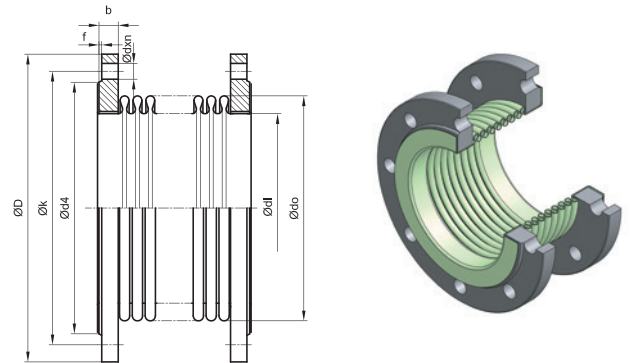
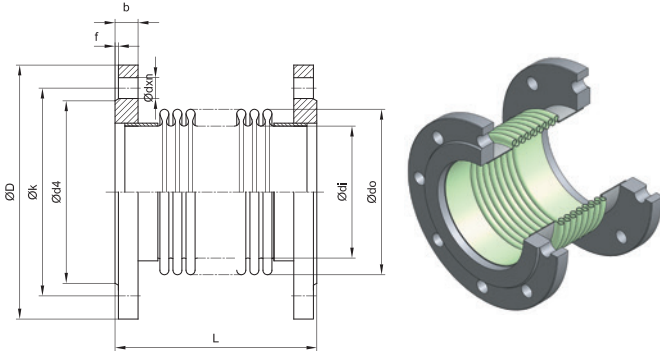

Bellows Information					MKSF-30		MKDF-30	
DN	Ødi	Ødo	Effective Bellows Area cm <sup>2</sup>	Axial Spring Rate N/mm	L	Code	L	Code
DN25	38	48,2	14,58	82,1	120	702.041.101.002	110	702.031.101.002
DN32	42,4	55	18,62	49,7	125	702.041.101.004	115	702.031.101.004
DN40	48,3	61	23,44	60,8	130	702.041.101.006	120	702.031.101.006
DN50	60,3	76	36,46	104,5	120	702.041.101.008	110	702.031.101.008
DN65	76,1	95	57,45	87,8	120	702.041.101.010	110	702.031.101.010
DN80	88,9	111	78,42	178,9	120	702.041.101.012	110	702.031.101.012
DN100	114,3	140	137,09	252,2	130	701.041.101.014	115	701.031.101.014
DN125	139,7	164	181,01	320,0	135	172.041.101.016	130	172.031.101.016
DN150	168,3	200	266,20	196,4	160	702.041.101.018	145	702.031.101.018
DN200	219,1	250	431,86	694,2	160	702.041.101.020	140	702.031.101.020
DN250	273	323	697,11	590,0	170	702.041.101.022	150	702.031.101.022
DN300	323,9	380	972,37	496,8	170	702.031.101.024	150	702.031.101.024

Flange (DIN EN 1092/1) PN 16						
DN	ØD	Øk	Ød4	f	b	Ødxn
DN25	115	85	68	2	16	Ø 14x4
DN32	140	100	78	2	18	Ø 18x4
DN40	150	110	88	3	18	Ø 18x4
DN50	165	125	102	3	20	Ø 18x4
DN65	185	145	122	3	20	Ø 18x4
DN80	200	160	138	3	20	Ø 18x8
DN100	220	180	158	3	22	Ø 18x8
DN125	250	210	188	3	22	Ø 18x8
DN150	285	240	212	3	24	Ø 23x8
DN200	340	295	268	3	26	Ø 23x12
DN250	405	355	320	3	29	Ø 27x12
DN300	460	410	378	4	32	Ø 27x12

Alternative flange dimensions are also possible e.g. according to US standards (ANSI), JIS etc.

\*All dimensions given in the tables are in "mm".

\*\* Subject to technical alterations and deviations resulting from production process without giving any notification.

Reduction Factors for Pressure			
Temperature °C	Reduction Factor Kp	Temperature °C	Reduction Factor Kp
20	1,00	350	0,64
100	0,85	400	0,63
150	0,81	450	0,62
200	0,77	500	0,60
250	0,71	550	0,59
300	0,68	600	0,57

### Pressure reduction factor

The reduction factor is used to define the design pressure [PS] where temperatures exceed 20 °C. It compensates for the decay in material mechanical properties at elevated temperatures. The calculated pressure is lower than the nominal pressure of the standard item.

$$\text{Calculation: } PS \leq PN \times Kp$$

# AXIAL EXPANSION JOINTS

## Axial Expansion Joint with 30mm expansion capacity with inner sleeve

With fixed flange			
Type	Expansion Amount	Available Sizes (DN)	Pressure Class (PN)
MKSF-30L	30 mm (-20/+10)	25-5000	16

With floating flanges			
Type	Expansion Amount	Available Sizes (DN)	Pressure Class (PN)
MKDF-30L	30 mm (-20/+10)	25-5000	16

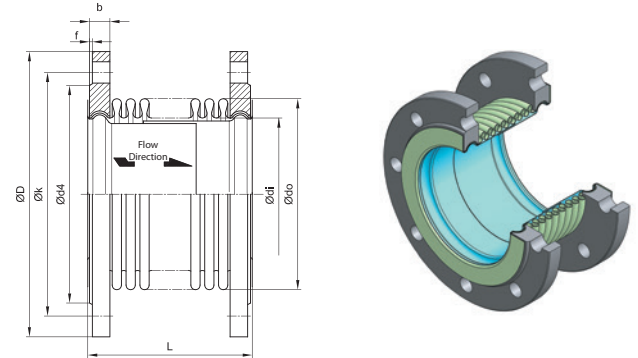
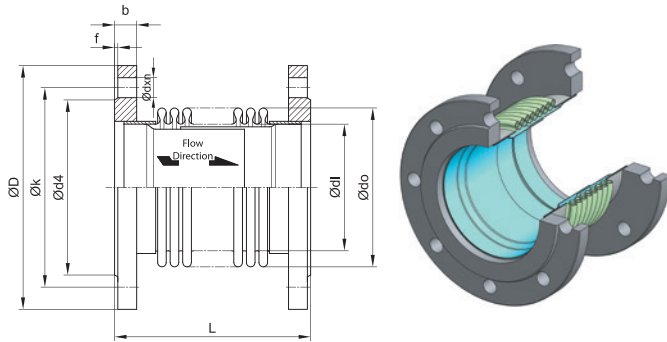

Bellows Information					MKSF-30		MKDF-30	
DN	$\varnothing di$	$\varnothing do$	Effective Bellows Area $cm^2$	Axial Spring Rate $N/mm$	L	Code	L	Code
DN25	38	48,2	14,58	82,1	120	702.041.102.002	110	702.031.102.002
DN32	42,4	55	18,62	49,7	125	702.041.102.004	115	702.031.102.004
DN40	48,3	61	23,44	60,8	130	702.041.102.006	120	702.031.102.006
DN50	60,3	76	36,46	104,5	120	702.041.102.008	110	702.031.102.008
DN65	76,1	95	57,45	87,8	120	702.041.102.010	110	702.031.102.010
DN80	88,9	111	78,42	178,9	120	702.041.102.012	110	702.031.102.012
DN100	114,3	140	137,09	252,2	130	701.041.102.014	115	701.031.102.014
DN125	139,7	164	181,01	320,0	135	172.041.102.016	130	172.031.102.016
DN150	168,3	200	266,20	196,4	160	702.041.102.018	145	702.031.102.018
DN200	219,1	250	431,86	694,2	160	702.041.102.020	140	702.031.102.020
DN250	273	323	697,11	590,0	170	702.041.102.022	150	702.031.102.022
DN300	323,9	380	972,37	496,8	170	702.031.102.024	150	702.031.102.024

Flange (DIN EN 1092/1) PN 16						
DN	$\varnothing D$	$\varnothing k$	$\varnothing d4$	f	b	$\varnothing dxn$
DN25	115	85	68	2	16	$\varnothing 14 \times 4$
DN32	140	100	78	2	18	$\varnothing 18 \times 4$
DN40	150	110	88	3	18	$\varnothing 18 \times 4$
DN50	165	125	102	3	20	$\varnothing 18 \times 4$
DN65	185	145	122	3	20	$\varnothing 18 \times 4$
DN80	200	160	138	3	20	$\varnothing 18 \times 8$
DN100	220	180	158	3	22	$\varnothing 18 \times 8$
DN125	250	210	188	3	22	$\varnothing 18 \times 8$
DN150	285	240	212	3	24	$\varnothing 23 \times 8$
DN200	340	295	268	3	26	$\varnothing 23 \times 12$
DN250	405	355	320	3	29	$\varnothing 27 \times 12$
DN300	460	410	378	4	32	$\varnothing 27 \times 12$

Alternative flange dimensions are also possible e.g. according to US standards (ANSI), JIS etc.

\*All dimensions given in the tables are in "mm".

\*\* Subject to technical alterations and deviations resulting from production process without giving any notification.

Reduction Factors for Pressure			
Temperature $^{\circ}C$	Reduction Factor $K_p$	Temperature $^{\circ}C$	Reduction Factor $K_p$
20	1,00	350	0,64
100	0,85	400	0,63
150	0,81	450	0,62
200	0,77	500	0,60
250	0,71	550	0,59
300	0,68	600	0,57

### Pressure reduction factor

The reduction factor is used to define the design pressure [PS] where temperatures exceed 20  $^{\circ}C$ . It compensates for the decay in material mechanical properties at elevated temperatures. The calculated pressure is lower than the nominal pressure of the standard item.

Calculation:  $PS \leq PN \times K_p$

# AXIAL EXPANSION JOINTS

## Axial Expansion Joint with 60mm expansion capacity with inner sleeve

With fixed flange			
Type	Expansion Amount	Available Sizes (DN)	Pressure Class (PN)
MKSF-60L	60 mm (-40/+20)	25-5000	16

With floating flanges			
Type	Expansion Amount	Available Sizes (DN)	Pressure Class (PN)
MKDF-60L	60 mm (-40/+20)	25-5000	16

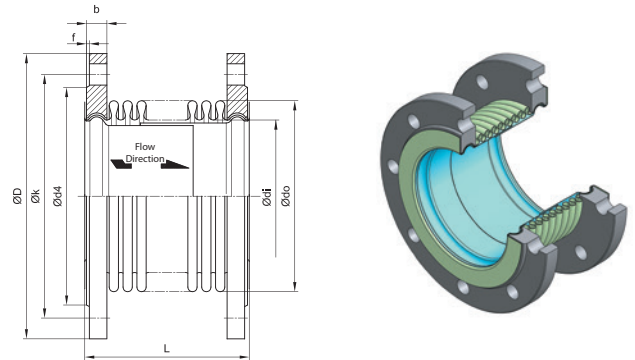
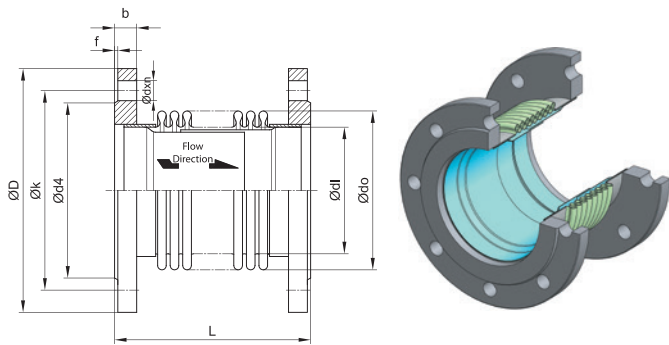

Bellows Information					MKSF60L		MKDF60L	
DN	$\varnothing di$	$\varnothing do$	Effective Bellows Area $cm^2$	Axial Spring Rate N/mm	L	Code	L	Code
DN50	60,3	76	36,46	55,7	200	702.041.202.008	190	702.031.202.008
DN65	76,1	95	57,45	43,9	205	702.041.202.010	195	702.031.202.010
DN80	88,9	111	78,42	89,4	200	702.041.202.012	190	702.031.202.012
DN100	114,3	140	137,09	126,1	215	701.041.202.014	200	701.031.202.014
DN125	139,7	164	181,01	160,0	225	172.041.202.016	210	172.031.202.016
DN150	168,3	200	266,20	98,2	250	702.041.202.018	245	702.031.202.018
DN200	219,1	250	431,86	347,1	265	702.041.202.020	245	702.031.202.020
DN250	273	323	697,11	295,0	270	702.041.202.022	250	702.031.202.022
DN300	323,9	380	972,37	248,4	170	702.031.202.024	250	702.031.202.024
DN200	219,1	250	431,86	694,2	160	702.041.102.020	140	702.031.102.020
DN250	273	323	697,11	590,0	170	702.041.102.022	150	702.031.102.022
DN300	323,9	380	972,37	496,8	170	702.031.102.024	150	702.031.102.024

Flange (DIN EN 1092/1) PN 16						
DN	$\varnothing D$	$\varnothing k$	$\varnothing d4$	f	b	$\varnothing dxn$
DN25	115	85	68	2	16	$\varnothing 14 \times 4$
DN32	140	100	78	2	18	$\varnothing 18 \times 4$
DN40	150	110	88	3	18	$\varnothing 18 \times 4$
DN50	165	125	102	3	20	$\varnothing 18 \times 4$
DN65	185	145	122	3	20	$\varnothing 18 \times 4$
DN80	200	160	138	3	20	$\varnothing 18 \times 8$
DN100	220	180	158	3	22	$\varnothing 18 \times 8$
DN125	250	210	188	3	22	$\varnothing 18 \times 8$
DN150	285	240	212	3	24	$\varnothing 23 \times 8$
DN200	340	295	268	3	26	$\varnothing 23 \times 12$
DN250	405	355	320	3	29	$\varnothing 27 \times 12$
DN300	460	410	378	4	32	$\varnothing 27 \times 12$

Alternative flange dimensions are also possible e.g. according to US standards (ANSI), JIS etc.

\*All dimensions given in the tables are in "mm".

\*\* Subject to technical alterations and deviations resulting from production process without giving any notification.

Reduction Factors for Pressure			
Temperature $^{\circ}C$	Reduction Factor $K_p$	Temperature $^{\circ}C$	Reduction Factor $K_p$
20	1,00	350	0,64
100	0,85	400	0,63
150	0,81	450	0,62
200	0,77	500	0,60
250	0,71	550	0,59
300	0,68	600	0,57

### Pressure reduction factor

The reduction factor is used to define the design pressure [PS] where temperatures exceed 20  $^{\circ}C$ . It compensates for the decay in material mechanical properties at elevated temperatures. The calculated pressure is lower than the nominal pressure of the standard item.

Calculation:  $PS \leq PN \times K_p$



# AXIAL EXPANSION JOINTS

## Axial Expansion Joint with Welded Ends

Without inner sleeve			
Type	Expansion Amount	Available Sizes (DN)	Pressure Class (PN)
MKKB-30	30 mm (-20/+10)	25-5000	16

With inner sleeve			
Type	Expansion Amount	Available Sizes (DN)	Pressure Class (PN)
MKKB-30L	30 mm (-20/+10)	25-5000	16
MKKB-60L	60 mm (-40/+20)	25-5000	16

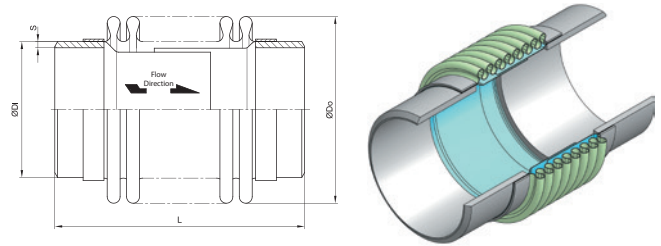
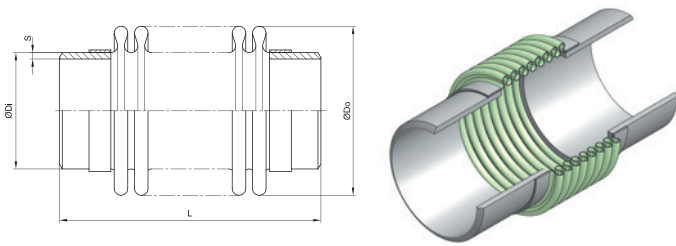

DN	Bellow				S	MKKB-30		MKKB-30L		MKKB-60L	
	ØDi	ØDo	Effective Bellow Area cm <sup>2</sup>	Axial Spring Rate N/mm		L	Code	L	Code	L	Code
DN25	38	48,2	14,58	82,1	2,6	210	702.051.101.006	210	702.051.102.006	N/A	
DN32	42,4	55	18,62	49,7	2,6	215	702.051.101.008	215	702.051.102.008		
DN40	48,3	61	23,44	60,8	2,6	220	702.051.101.010	220	702.051.102.010		
DN50	60,3	76	36,46	104,5	2,9	210	702.051.101.012	210	702.051.102.012	290	702.051.202.012
DN65	76,1	95	57,45	87,8	2,9	210	702.051.101.014	210	702.051.102.014	285	701.051.202.014
DN80	88,9	111	78,42	178,9	3,2	215	702.051.101.016	215	702.051.102.016	300	172.051.202.016
DN100	114,3	140	137,09	252,2	3,6	215	702.051.101.018	215	702.051.102.018	300	702.051.202.018
DN125	139,7	164	181,01	320,0	4,0	220	702.051.101.020	220	702.051.102.020	310	702.051.202.020
DN150	168,3	200	266,20	196,4	4,5	245	702.051.101.022	245	702.051.102.022	345	702.051.202.022
DN200	219,1	250	431,86	694,2	6,3	235	702.051.101.024	235	702.051.102.024	340	702.051.202.024
DN250	273	323	697,11	590,0	6,3	240	702.051.101.026	240	702.051.102.026	340	702.051.202.026
DN300	323,9	380	972,37	496,8	7,1	250	702.051.101.028	250	702.051.102.028	340	702.051.202.028

\*All dimensions given in the tables are in "mm".  
 \*\* Subject to technical alterations and deviations resulting from production process without giving any notification.

Reduction Factors for Pressure			
Temperature °C	Reduction Factor Kp	Temperature °C	Reduction Factor Kp
20	1,00	350	0,64
100	0,85	400	0,63
150	0,81	450	0,62
200	0,77	500	0,60
250	0,71	550	0,59
300	0,68	600	0,57

### Pressure reduction factor

The reduction factor is used to define the design pressure [PS] where temperatures exceed 20 °C. It compensates for the decay in material mechanical properties at elevated temperatures. The calculated pressure is lower than the nominal pressure of the standard item.

Calculation:  $PS \leq PN \times Kp$



## X-PRESSED AXIAL EXPANSION JOINTS

### X-Pressed Expansion Joints (One end with Fixed, other end with Floating Flange)

With fixed flange			
Type	Expansion Amount	Available Sizes (DN)	Pressure Class (PN)
DBKF-30	30 mm (-20/+10)	25-5000	16

With floating flanges			
Type	Expansion Amount	Available Sizes (DN)	Pressure Class (PN)
DBKF-60	60 mm (-40/+20)	25-5000	16

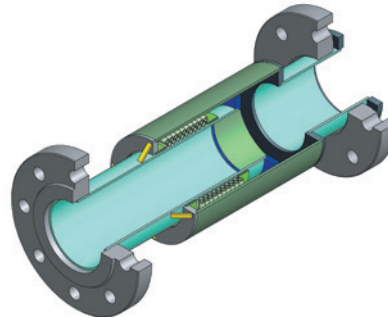
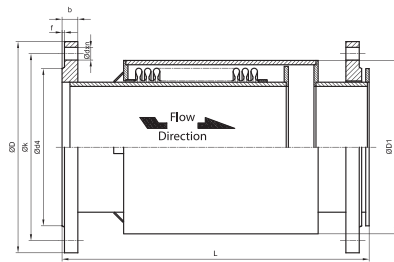

Bellows Information				DBKF-30			DBKF-60		
DN	Ødi	Ødo	Effective Bellows Area cm <sup>2</sup>	L	Axial Spring Rate N/mm	Code	L	Axial Spring Rate N/mm	Code
DN25	38	48,2	14,58	360	82,1	702.060.201.002	490	41,1	702.060.202.002
DN32	42,4	55	18,62	360	49,7	702.060.201.004	490	24,8	702.060.202.004
DN40	48,3	61	23,44	380	60,8	702.060.201.006	500	30,4	702.060.202.006
DN50	60,3	76	36,46	370	104,5	702.060.201.008	480	55,7	702.060.202.008
DN65	76,1	95	57,45	370	87,8	702.060.201.010	470	43,9	702.060.202.010
DN80	88,9	111	78,42	370	178,9	702.060.201.012	470	89,4	702.060.202.012
DN100	114,3	140	137,09	380	252,2	702.060.201.014	480	126,1	702.060.202.014
DN125	139,7	164	181,01	380	320,0	702.060.201.016	490	160,0	702.060.202.016
DN150	168,3	200	266,20	400	196,4	702.060.201.018	510	98,2	702.060.202.018
DN200	219,1	250	431,86	420	694,2	702.060.201.020	530	347,1	702.060.202.020
DN250	273	323	697,11	440	590,0	702.060.201.022	540	295,0	702.060.202.022
DN300	323,9	380	972,37	460	496,8	702.060.201.024	570	248,4	702.060.202.024

Flange (DIN EN 1092/1) PN 16							
DN	ØD	Øk	Ød4	f	b	Ødxn	
DN25	115	85	68	2	16	Ø 14x4	
DN32	140	100	78	2	18	Ø 18x4	
DN40	150	110	88	3	18	Ø 18x4	
DN50	165	125	102	3	20	Ø 18x4	
DN65	185	145	122	3	20	Ø 18x4	
DN80	200	160	138	3	20	Ø 18x8	
DN100	220	180	158	3	22	Ø 18x8	
DN125	250	210	188	3	22	Ø 18x8	
DN150	285	240	212	3	24	Ø 23x8	
DN200	340	295	268	3	26	Ø 23x12	
DN250	405	355	320	3	29	Ø 27x12	
DN300	460	410	378	4	32	Ø 27x12	

Alternative flange dimensions are also possible e.g. according to US standards (ANSI), JIS etc.

\* All the dimensions in the table are given in "mm".

\*\* Subject to technical alterations and deviations resulting from the manufacturing process without giving any notification.

Reduction Factors for Pressure			
Temperature °C	Reduction Factor Kp	Temperature °C	Reduction Factor Kp
20	1,00	350	0,64
100	0,85	400	0,63
150	0,81	450	0,62
200	0,77	500	0,60
250	0,71	550	0,59
300	0,68	600	0,57

### Pressure reduction factor

The reduction factor is used to define the design pressure [PS] where temperatures exceed 20 °C. It compensates for the decay in material mechanical properties at elevated temperatures. The calculated pressure is lower than the nominal pressure of the standard item.

Calculation:  $PS \leq PN \times Kp$



# X-PRESSED AXIAL EXPANSION JOINTS

## X-Pressed Expansion Joints (One end with Fixed, other end with Floating Flange)

With fixed flange			
Type	Expansion Amount	Available Sizes (DN)	Pressure Class (PN)
DBKF-90	90 mm (-70/+20)	25-5000	16

With floating flanges			
Type	Expansion Amount	Available Sizes (DN)	Pressure Class (PN)
DBKF-120	120 mm (-100/+20)	25-5000	16

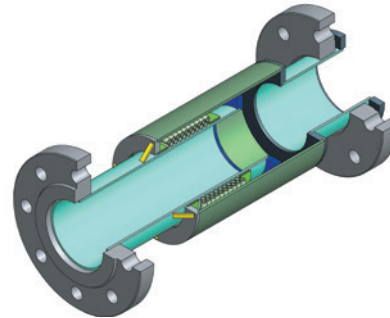
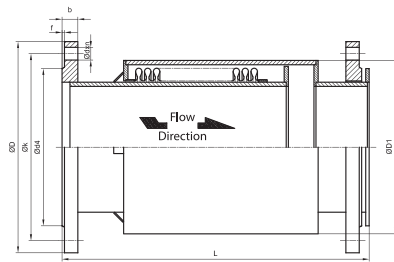

Bellows Information				DBKF-90			DBKF-120		
DN	Ødi	Ødo	Effective Bellows Area cm <sup>2</sup>	L	Axial Spring Rate N/mm	Code	L	Axial Spring Rate N/mm	Code
DN25	38	48,2	14,58	520	41,1	702.060.203.002	600	34,2	702.060.204.002
DN32	42,4	55	18,62	520	24,8	702.060.203.004	660	17,7	702.060.204.004
DN40	48,3	61	23,44	530	30,4	702.060.203.006	680	20,3	702.060.204.006
DN50	60,3	76	36,46	510	55,7	702.060.203.008	680	32,1	702.060.204.008
DN65	76,1	95	57,45	500	43,9	702.060.203.010	740	23,6	702.060.204.010
DN80	88,9	111	78,42	500	89,4	702.060.203.012	650	55,9	702.060.204.012
DN100	114,3	140	137,09	510	126,1	702.060.203.014	690	78,8	702.060.204.014
DN125	139,7	164	181,01	520	160	702.060.203.016	700	100	702.060.204.016
DN150	168,3	200	266,20	540	98,2	702.060.203.018	700	70,1	702.060.204.018
DN200	219,1	250	431,86	560	347,1	702.060.203.020	770	198,3	702.060.204.020
DN250	273	323	697,11	570	295	702.060.203.022	830	177	702.060.204.022
DN300	323,9	380	972,37	600	248,4	702.060.203.024	810	149	702.060.204.024

Flange (DIN EN 1092/1) PN 16							
DN	ØD	Øk	Ød4	f	b	Ødxn	
DN25	115	85	68	2	16	Ø 14x4	
DN32	140	100	78	2	18	Ø 18x4	
DN40	150	110	88	3	18	Ø 18x4	
DN50	165	125	102	3	20	Ø 18x4	
DN65	185	145	122	3	20	Ø 18x4	
DN80	200	160	138	3	20	Ø 18x8	
DN100	220	180	158	3	22	Ø 18x8	
DN125	250	210	188	3	22	Ø 18x8	
DN150	285	240	212	3	24	Ø 23x8	
DN200	340	295	268	3	26	Ø 23x12	
DN250	405	355	320	3	29	Ø 27x12	
DN300	460	410	378	4	32	Ø 27x12	

Alternative flange dimensions are also possible e.g. according to US standards (ANSI), JIS etc.

\* All the dimensions in the table are given in "mm".

\*\* Subject to technical alterations and deviations resulting from the manufacturing process without giving any notification.

Reduction Factors for Pressure			
Temperature °C	Reduction Factor Kp	Temperature °C	Reduction Factor Kp
20	1,00	350	0,64
100	0,85	400	0,63
150	0,81	450	0,62
200	0,77	500	0,60
250	0,71	550	0,59
300	0,68	600	0,57

### Pressure reduction factor

The reduction factor is used to define the design pressure [PS] where temperatures exceed 20 °C. It compensates for the decay in material mechanical properties at elevated temperatures. The calculated pressure is lower than the nominal pressure of the standard item.

Calculation:  $PS \leq PN \times Kp$

## X-PRESSED AXIAL EXPANSION JOINTS

### X-Pressed Expansion Joints (Welded Ends)

With fixed flange			
Type	With Welded End	Available Sizes (DN)	Pressure Class (PN)
DBKK-30	30 mm (-20/+10)	25-5000	16

With floating flanges			
Type	With Welded End	Available Sizes (DN)	Pressure Class (PN)
DBKK-60	60 mm (-40/+20)	25-5000	16

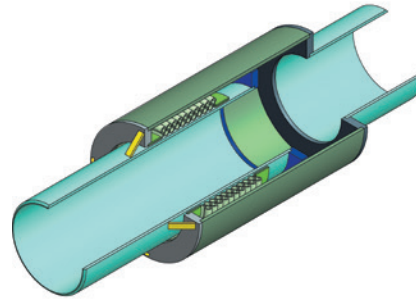
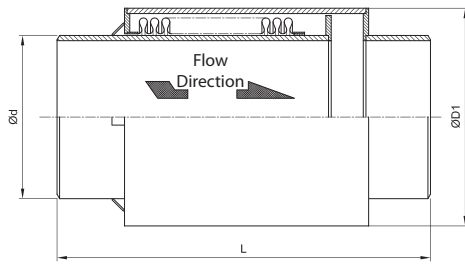

Bellows Information				DBKK-30			DBKK-60		
DN	Ødi	Ødo	Effective Bellows Area cm <sup>2</sup>	L	Axial Spring Rate N/mm	Code	L	Axial Spring Rate N/mm	Code
DN25	38	48,2	14,58	340	82,1	702.060.101.002	470	41,1	702.060.102.002
DN32	42,4	55	18,62	340	49,7	702.060.101.004	470	24,8	702.060.102.004
DN40	48,3	61	23,44	360	60,8	702.060.101.006	480	30,4	702.060.102.006
DN50	60,3	76	36,46	350	104,5	702.060.101.008	460	55,7	702.060.102.008
DN65	76,1	95	57,45	350	87,8	702.060.101.010	450	43,9	702.060.102.010
DN80	88,9	111	78,42	350	178,9	702.060.101.012	450	89,4	702.060.102.012
DN100	114,3	140	137,09	360	252,2	702.060.101.014	460	126,1	702.060.102.014
DN125	139,7	164	181,01	360	320,0	702.060.101.016	470	160	702.060.102.016
DN150	168,3	200	266,20	380	196,4	702.060.101.018	490	98,2	702.060.102.018
DN200	219,1	250	431,86	400	694,2	702.060.101.020	510	347,1	702.060.102.020
DN250	273	323	697,11	420	590,0	702.060.101.022	520	295	702.060.102.022
DN300	323,9	380	972,37	440	496,8	702.060.101.024	550	248,4	702.060.102.024

\* All the dimensions in the table are given in "mm".

\*\* Subject to technical alterations and deviations resulting from the manufacturing process without giving any notification.

Reduction Factors for Pressure			
Temperature °C	Reduction Factor Kp	Temperature °C	Reduction Factor Kp
20	1,00	350	0,64
100	0,85	400	0,63
150	0,81	450	0,62
200	0,77	500	0,60
250	0,71	550	0,59
300	0,68	600	0,57

#### Pressure reduction factor

The reduction factor is used to define the design pressure [PS] where temperatures exceed 20 °C. It compensates for the decay in material mechanical properties at elevated temperatures. The calculated pressure is lower than the nominal pressure of the standard item.

Calculation:  $PS \leq PN \times Kp$

## X-PRESSED AXIAL EXPANSION JOINTS

### X-Pressed Expansion Joints (Welded End)

Welded End			
Type	Expansion Amount	Available Sizes (DN)	Pressure Class (PN)
DBKK-90	90 mm (-70/+20)	25-5000	16

Welded End			
Type	Expansion Amount	Available Sizes (DN)	Pressure Class (PN)
DBKK-120	120 mm (-100/+20)	25-5000	16

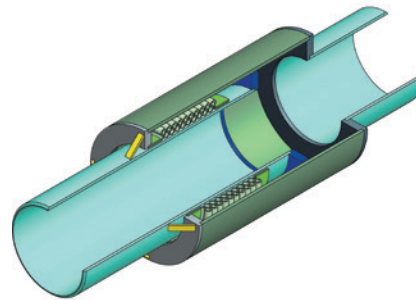
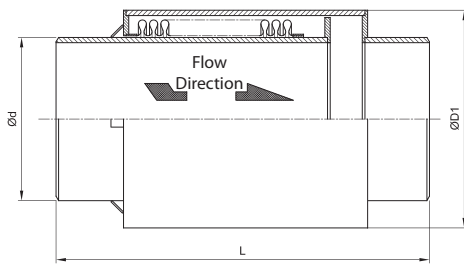

Bellows Information				DBKK-90			DBKK-120		
DN	Ødi	Ødo	Effective Bellows Area cm <sup>2</sup>	L	Axial Spring Rate N/mm	Code	L	Axial Spring Rate N/mm	Code
DN25	38	48,2	14,58	500	41,1	702.060.103.002	580	34,2	702.060.104.002
DN32	42,4	55	18,62	500	24,8	702.060.103.004	640	17,7	702.060.104.004
DN40	48,3	61	23,44	510	30,4	702.060.103.006	660	20,3	702.060.104.006
DN50	60,3	76	36,46	490	55,7	702.060.103.008	660	32,1	702.060.104.008
DN65	76,1	95	57,45	480	43,9	702.060.103.010	720	23,6	702.060.104.010
DN80	88,9	111	78,42	480	89,4	702.060.103.012	630	55,9	702.060.104.012
DN100	114,3	140	137,09	490	126,1	702.060.103.014	670	78,8	702.060.104.014
DN125	139,7	164	181,01	500	160	702.060.103.016	680	100	702.060.104.016
DN150	168,3	200	266,20	520	98,2	702.060.103.018	680	70,1	702.060.104.018
DN200	219,1	250	431,86	540	347,1	702.060.103.020	750	198,3	702.060.104.020
DN250	273	323	697,11	550	295	702.060.103.022	810	177	702.060.104.022
DN300	323,9	380	972,37	580	248,4	702.060.103.024	790	149	702.060.104.024

\* All the dimensions in the table are given in "mm".

\*\* Subject to technical alterations and deviations resulting from the manufacturing process without giving any notification.

Reduction Factors for Pressure			
Temperature °C	Reduction Factor Kp	Temperature °C	Reduction Factor Kp
20	1,00	350	0,64
100	0,85	400	0,63
150	0,81	450	0,62
200	0,77	500	0,60
250	0,71	550	0,59
300	0,68	600	0,57

### Pressure reduction factor

The reduction factor is used to define the design pressure [PS] where temperatures exceed 20 °C. It compensates for the decay in material mechanical properties at elevated temperatures. The calculated pressure is lower than the nominal pressure of the standard item.

Calculation:  $PS \leq PN \times Kp$





Scan this QR Code



Ayvaz's special stainless steel expansion joints with carbon steel weld ends are designed to be used for compensating movements and misalignments in exhaust systems in situations with relatively high axial or small lateral movements and combination of these at the same time. Due to the double ply bellows, exhaust expansion joints are more flexible and their life cycle is greater than the simple expansion joints. According to the maximum operating temperature, weld end material could also be made by stainless steel or nickel alloys.

### Advantages of District Heating Expansion Joints

- Bellows design according to EJMA coding system.
- Construction according to EN14917 standard.
- Absorption of high axial and lateral movements
- High Life cycle design
- Lower spring rate values
- Easy installation and maintenance.

### Application Areas

- Exhaust Systems
- Vibration absorption
- Industrial process & applications

### DESIGN (EN 14917&EJMA)

Bellow Material	Stainless Steel AISI 321 (Opt.304,316L,316TI,309)
Connection Types	Welded Ended
Welded End Material	Carbon steel St 37,2 or Stainless Steel
Inner Sleeve	Available in stainless steel AISI 321 (opt.304,316L,316TI,309) on request
Accessories	Inner sleeve, cover, counter flange, gaskets, insulation etc. are available on request.
Certificates	Material certificate 3.1 according to EN 10204 and /or ASME PED 2014/68/EU SEP (Sound Engineering Practice)

### Operation Conditions

Operating Temperature	-10C°/+550C°, higher temperatures at peak conditions are possible.
Operating Pressure	Standard pressure rating is PN2,5 & PN6 PN corresponds to the allowable operating pressure at room temperature

### Important

For detailed information, get in contact with Ayvaz's expert sales team. We strongly advise against the use of expansion joints and bellows for misalignment. Torsion on bellow parts are not desirable and should be eliminated.

## EXHAUST EXPANSION JOINTS

### Exhaust Expansion Joints (PN2,5)

Exhaust Expansion Joints with Welded Ends		
Type	Pressure Class (PN)	Available Size (DN)
EGZKKB-1	2,5 Bar	DN40-DN5000

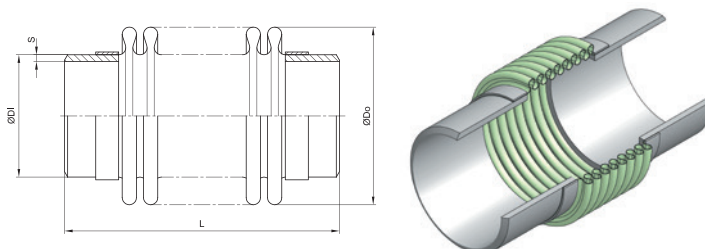

Bellows Information				Pipe Thickness Carbon Steel "s"	Pipe Thickness Stainless Steel "s"	EGZKKB-1			
DN	Ødi	Ødo	Effective Bellow Area cm <sup>2</sup>			Axial Movement "±"	Lateral Movement "±"	Lateral Spring Rate N/mm	Total Length "L"
DN40	48,3	63	24,32	2,6	2	20	15	6	245
DN50	60,3	79	38,1	2,9	2	30	15	10	305
DN65	76,1	96,7	58,63	2,9	2	30	15	13	305
DN80	88,9	114	80,83	3,2	2	30	15	22	305
DN100	114,3	142	128,98	3,6	2	35	15	29	305
DN125	139,7	168	185,9	3,6	2	35	15	51	305
DN150	168,3	203	270,69	4,0	2	35	15	62	305
DN200	219,1	254	439,48	4,5	2	35	13	115	305
DN250	273	314	676,56	5,0	2	35	12	181	310
DN300	323,9	370	945,42	5,6	2	40	7	420	300
DN350	355,6	401	1123,99	5,6	3	40	8	478	325
DN400	406,4	450	1440,07	5,6	3	40	7	573	325

\* All the dimensions in the table are given in "mm".

\*\* Subject to technical alterations and deviations resulting from the manufacturing process without giving any notification

\*\*\* Movements are not in combination.

Reduction Factors for Pressure			
Temperature °C	Reduction Factor Kp	Temperature °C	Reduction Factor Kp
20	1,00	350	0,64
100	0,85	400	0,63
150	0,81	450	0,62
200	0,77	500	0,60
250	0,71	550	0,59
300	0,68	600	0,57

#### Pressure reduction factor

The reduction factor is used to define the design pressure [PS] where temperatures exceed 20°C, it compensates for the decay in material mechanical properties at elevated temperatures. The calculated pressure is lower than the nominal pressure of the standard item

Calculation:  $PS \leq PN \times Kp$

## District Heating Expansion Joints

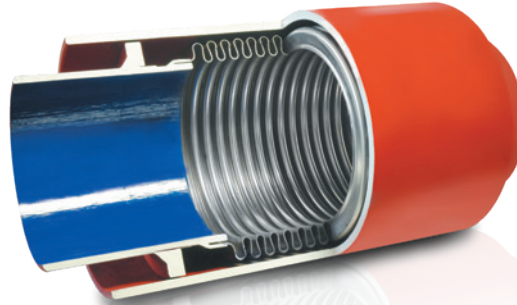

Scan this QR Code



Ayvaz's highly flexible metal bellowed expansion joints are designed to absorb large axial movements specially for installation in district heating pipe systems.

### Movement Absorption

The highly flexible bellow of the compensator ensures absorption of large axial movements. The cover, guides and rings of the compensator contribute high stability. The cover likewise absorbs eventual misalignments in the pipeline, which can occur if the pipeline hangs a bit in the compensator.

### Advantages of District Heating Expansion Joints

- Bellows design according to EJMA coding system.
- Construction according to EN14917 standard.
- Absorption of large axial movements
- Protection against mechanical damage through completely closed external pipes
- Easy installation and insulation
- Protection against

### DESIGN (EN 14917&EJMA)

Bellow Material	Stainless Steel AISI 321 (Opt.304,316L,316Ti,309)
Connection Types	Fixed and Floating Flanged, Welded Ended & Grooved
Welded Ends	St.37.2 as standard, the material can be customised on request
Inner Sleeve	Available in stainless steel AISI 321 (Opt. 304,316L,316Ti,309) on request
Accessories	Inner sleeve, cover, counter flange, gaskets, insulation etc. are available on request.
Certificates	Material certificate 3.1 according to EN 10204 and /or ASME PED 2014/68/EU Cat.III Mod.H

### Operation Conditions

Operating Temperature	-10°C/+550°C
Operating Pressure	Standard pressure rating is PN16 Can be produced with different pressure rates PN 2,5-63 PN corresponds to the allowable operating pressure at room temperature

### Important

Standard models are produced as un-restrained, fixed points should be created as to withstand springing force as well as pressure thrust caused by the system pressure. For detailed information, get in contact with Ayvaz's expert sales team. We strongly advise against the use of expansion joints and bellows for misalignment. Torsion on bellow parts are not desirable and should be eliminated.

# DISTRICT HEATING EXPANSION JOINTS

## District Heating Expansion Joints

Single Bellowed with welded ends			
Type	Expansion Amount	Available Sizes (DN)	Pressure Class (PN)
DSTKKB-1	±30/±105	50-1000	16

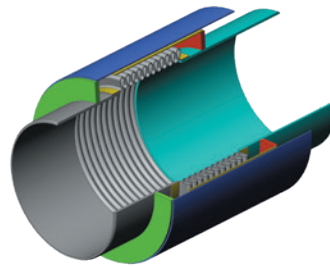
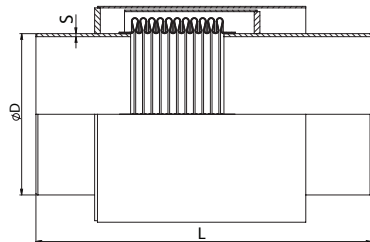

DN	ØD	s	L	Axial Movement (+/- mm)	Axial Spring Rate N/mm	Effective Bellow Area cm <sup>2</sup>	Life Cycle (100%)	Life Cycle (50%)	Life Cycle (33%)	Code
DN50	60,3	2,9	540	+/- 30 mm	166	36,64	83	1187	6617	702151060014
DN65	76,1	2,9	550	+/- 30 mm	120	58,83	100	1374	7223	702151060016
DN80	88,9	3,2	570	+/- 35 mm	115	83,24	81	1011	4783	702151070018
DN100	114,3	3,6	620	+/- 50 mm	168	129,99	61	807	4055	702151100020
DN125	139,7	4	630	+/- 50 mm	237	182,3	66	908	4781	702151100022
DN150	168,3	4,5	640	+/- 50 mm	206	266,34	72	933	4599	702151100024
DN200	219,1	6,3	750	+/- 70 mm	239	443,2	72	951	4793	702151140026
DN250	273	6,3	780	+/- 80 mm	243	681,18	71	895	4280	702151160028
DN300	323,9	7,1	790	+/- 90 mm	305	950,88	79	1017	5021	702151180030
DN350	355,6	8	800	+/- 90 mm	320	1153,9	85	1072	5139	702151180032
DN400	406,4	8	840	+/- 100 mm	493	1490,96	78	1032	5259	702151200034
DN500	508	8	830	+/- 100 mm	565	2281,75	73	954	4746	702151200038
DN600	609,6	8	890	+/- 100 mm	902	3250,25	69	925	4768	702151200042
DN700	711,2	8	1010	+/- 105 mm	893	4377,9	72	925	4857	702151210046
DN800	812,8	8	1050	+/- 105 mm	1450	5633,19	76	1072	5813	702151210050
DN900	914,4	10	1050	+/- 105 mm	1593	7068,83	77	1085	5885	702151210054
DN1000	1016	10	1080	+/- 105 mm	1354	8766,55	96	1314	6878	702151210058

\* All the dimensions in the table are given in "mm".

\*\* Subject to technical alterations and deviations resulting from the manufacturing process without giving any notification.

Reduction Factors for Pressure			
Temperature °C	Reduction Factor Kp	Temperature °C	Reduction Factor Kp
20	1,00	350	0,64
100	0,85	400	0,63
150	0,81	450	0,62
200	0,77	500	0,60
250	0,71	550	0,59
300	0,68	600	0,57

### Pressure reduction factor

The reduction factor is used to define the design pressure [PS] where temperatures exceed 20 °C. It compensates for the decay in material mechanical properties at elevated temperatures. The calculated pressure is lower than the nominal pressure of the standard item.

Calculation:  $PS \leq PN \times Kp$



## DISTRICT HEATING EXPANSION JOINTS

### District Heating Expansion Joints

Double Bellowed with welded ends			
Type	Expansion Amount	Available Sizes (DN)	Pressure Class (PN)
DSTKKB-2	±60/±210	50-1000	16

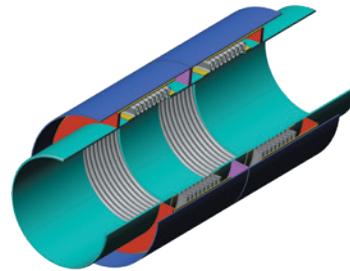
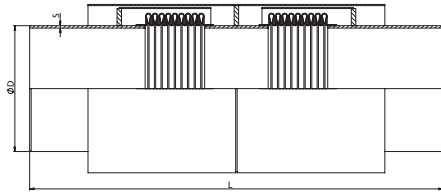

DN	ØD	s	L	Axial Movement (+/- mm)	Axial Spring Rate N/mm	Effective Bellow Area cm <sup>2</sup>	Life Cycle (100%)	Life Cycle (50%)	Life Cycle (33%)	Code
DN200	219,1	6,3	1280	+/- 140 mm	556	443,2	60	865	4842	702152060026
DN250	273	6,3	1340	+/- 160 mm	551	681,18	59	841	4625	702152060028
DN300	323,9	7,1	1370	+/- 180 mm	685	950,88	69	998	2627	702152060030
DN350	355,6	8	1390	+/- 180 mm	752	1153,9	82	1212	6949	702152060032
DN400	406,4	8	1460	+/- 200 mm	878	1490,96	70	1018	5755	702152060034
DN500	508	8	1450	+/- 200 mm	741	2320,01	64	907	4929	702152060038
DN600	609,6	8	1570	+/- 200 mm	892	3250,25	63	886	4844	702152060042
DN700	711,2	8	1800	+/- 210 mm	873	4377,9	68	964	5210	702152060046
DN800	812,8	8	1880	+/- 210 mm	984	5633,19	72	1034	5732	702152060050
DN900	914,4	10	1870	+/- 210 mm	1070	7068,83	71	1015	5636	702152060054
DN1000	1016	10	1930	+/- 210 mm	1213	8659,01	66	936	5138	702152060058

\* All the dimensions in the table are given in "mm".

\*\* Subject to technical alterations and deviations resulting from the manufacturing process without giving any notification.

Reduction Factors for Pressure			
Temperature °C	Reduction Factor Kp	Temperature °C	Reduction Factor Kp
20	1,00	350	0,64
100	0,85	400	0,63
150	0,81	450	0,62
200	0,77	500	0,60
250	0,71	550	0,59
300	0,68	600	0,57

#### Pressure reduction factor

The reduction factor is used to define the design pressure [PS] where temperatures exceed 20 °C. It compensates for the decay in material mechanical properties at elevated temperatures. The calculated pressure is lower than the nominal pressure of the standard item.

Calculation:  $PS \leq PN \times Kp$

## PIPE EXPANSION JOINTS



Scan this QR Code



### Movement Absorption

Pipe expansion joints provide axial movement absorption and maintain the pipeline security. A heating pipeline system at 90/70°C causes approximately 3 mm of movement for each floor of the buildings. For the buildings higher than 10 floors, use of the pipe expansion joints becomes compulsory in order to absorb total expansion amount. Pipe expansion joint application must be repeated for each section between 8-10 floors.

### Advantages of Pipe Expansion Joints

- They prevent damage to pipelines result of the line movements
- They absorb the possible noises and provide convenience for the users
- They are installed easily and provide time and money saving
- They have a compact and decorative design that reduces the waste of space
- They help to protect equipment from stress due to misalignment

### Application Areas

- HVAC piping lines

### DESIGN (EN 14917)

Body	Aluminium External Pipe up to DN50 above DN 50 Stainless Steel
Bellow Material	Stainless Steel AISI 316L & 321
Connection Types	Welded Ended & Threaded
Connection Material	St 37.2 as standard
Inner Sleeve	Built in internal pipe (St 37.2) operates like inner sleeve

### Operation Conditions

Operating Temperature	-10°C/+100°C
Operating Pressure	Standard pressure rating is PN16 Can be produced with different pressure rates PN corresponds to the allowable operating pressure at room temperature

### Important

Standard models are produced as un-restrained, fixed points should be created as to withstand springing force as well as pressure thrust caused by the system pressure. For detailed information, get in contact with Ayvaz's expert sales team. We strongly advise against the use of expansion joints and bellows for misalignment. Torsion on bellow parts are not desirable and should be eliminated.

## PIPE EXPANSION JOINTS

Threaded, Pipe Expansion Joints			
Type	Movement	Available Size (inch)	Pressure Class (PN)
BKD-50	50mm (-45/+5)	1/2"-2"	16
	50mm (-35/+15)	2½"-5"	

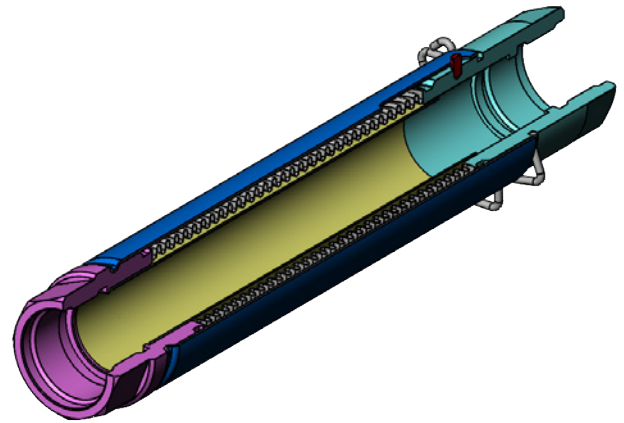
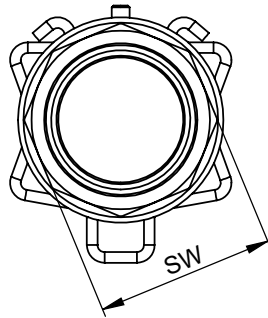
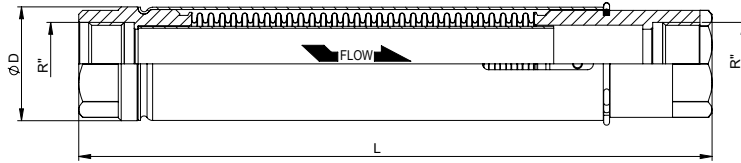

Bellows Information					BKD-50			
Size	Inner Diameter	Axial Movement mm	Effective Area cm <sup>2</sup>	Axial Spring Rate N/mm	ØD	SW	L	Code
1/2"	21,3	+5/-45	7,5	18	38	32	290	702020050002
3/4"	26,9	+5/-45	7,5	18	38	32	290	702020050004
1"	33,7	+5/-45	11	16	48	41	285	702020050006
1 1/4"	42,2	+5/-45	17,8	19	60	50	320	702020050008
1 1/2"	48,3	+5/-45	26	22	75	65	320	702020050010
2"	60,3	+5/-45	26	22	75	65	320	702020050012

\* All the dimensions in the table are given in "mm".

\*\* Subject to technical alterations and deviations resulting from the manufacturing process without giving any notification.

Reduction Factors for Pressure			
Temperature °C	Reduction Factor Kp	Temperature °C	Reduction Factor Kp
20	1,00	350	0,64
100	0,85	400	0,63
150	0,81	450	0,62
200	0,77	500	0,60
250	0,71	550	0,59
300	0,68	600	0,57

### Pressure reduction factor

The reduction factor is used to define the design pressure [PS] where temperatures exceed 20 °C. It compensates for the decay in material mechanical properties at elevated temperatures. The calculated pressure is lower than the nominal pressure of the standard item.

Calculation:  $PS \leq PN \times Kp$

## PIPE EXPANSION JOINTS

Welded Ends, Pipe Expansion Joints			
Type	Movement	Available Size (DN)	Pressure Class (PN)
BKKB-50	50mm (-45/+5)	15-50	16

Welded Ends, Pipe Expansion Joints			
Type	Movement	Available Size (DN)	Pressure Class (PN)
BKKB-50	50mm (-35/+15)	65-150	16

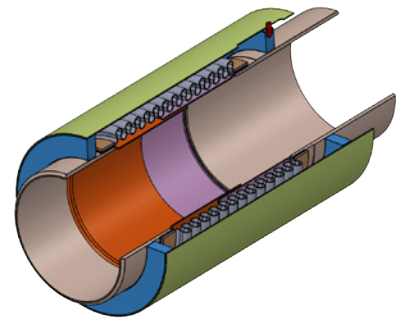
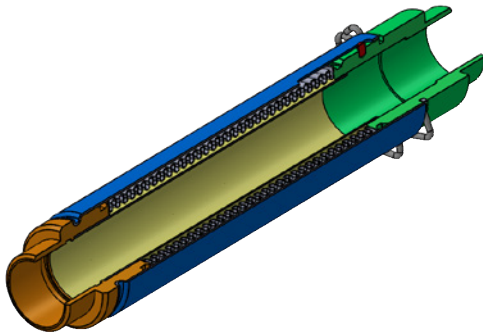
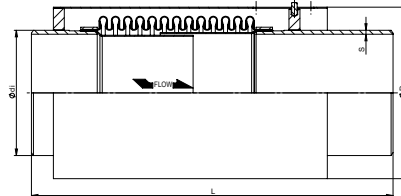
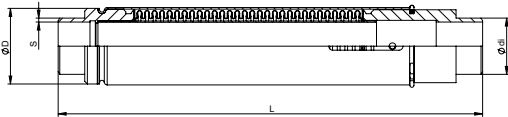

Bellows Information					BKKB-50			
Size	Inner Diameter	Axial Movement mm	Effective Area cm <sup>2</sup>	Axial Spring Rate N/mm	ØD	S	L	Code
DN15	21,3	+5/-45	7,5	18	38	2,5	290	702020030002
DN20	26,9	+5/-45	7,5	18	38	3	290	702020030004
DN25	33,7	+5/-45	11	16	48	3	285	702020030006
DN32	42,2	+5/-45	17,8	19	60	3	320	702020030008
DN40	48,3	+5/-45	26	22	75	3	320	702020030010
DN50	60,3	+5/-45	26	22	75	3	320	702020030012
DN65	76,1	+15/-35	57,5	65	107	2,9	330	702020030014
DN80	88,9	+15/-35	78,5	91	127	3,2	330	702020030016
DN100	114,3	+15/-35	126,7	148	158	3,6	330	702020030018
DN125	139,7	+15/-35	181,1	199	180	4	330	702020030020
DN150	168,3	+15/-35	266,4	213	220	4,5	400	702020030022

\* All the dimensions in the table are given in "mm".

\*\* Subject to technical alterations and deviations resulting from the manufacturing process without giving any notification.

Reduction Factors for Pressure			
Temperature °C	Reduction Factor Kp	Temperature °C	Reduction Factor Kp
20	1,00	350	0,64
100	0,85	400	0,63
150	0,81	450	0,62
200	0,77	500	0,60
250	0,71	550	0,59
300	0,68	600	0,57

### Pressure reduction factor

The reduction factor is used to define the design pressure [PS] where temperatures exceed 20 °C. It compensates for the decay in material mechanical properties at elevated temperatures. The calculated pressure is lower than the nominal pressure of the standard item.

Calculation:  $PS \leq PN \times Kp$



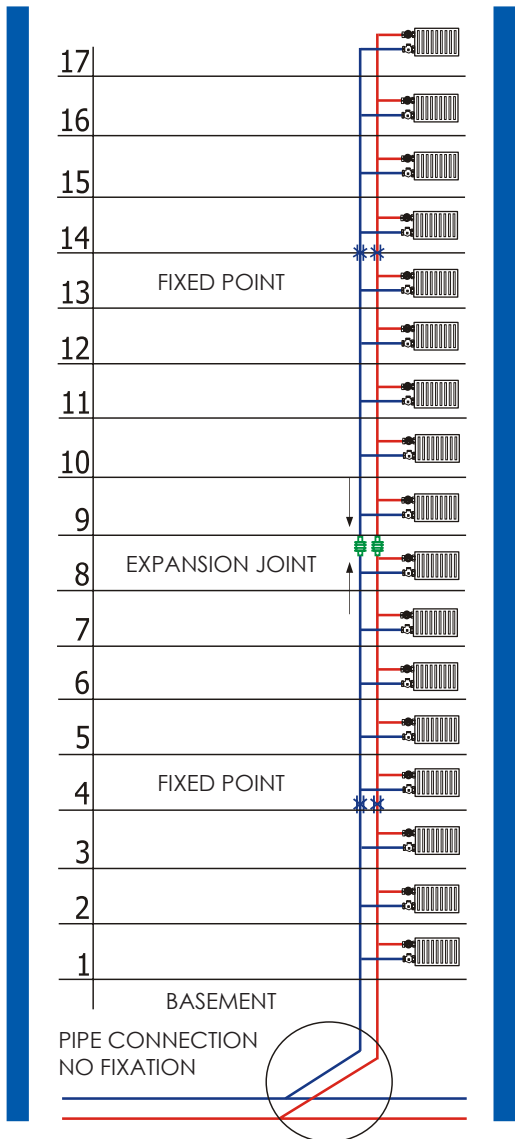
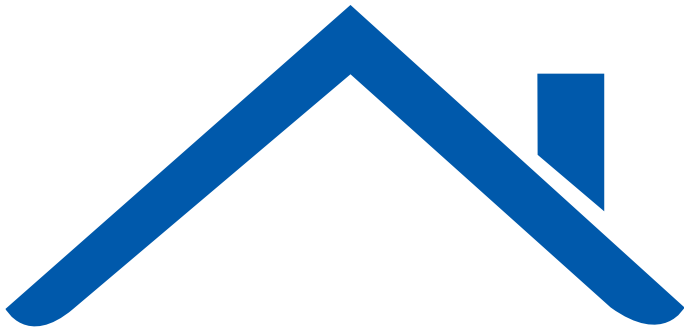

**THERMAL EXTENSION CALCULATION & EXPANSION JOINT SELECTION (DN15-DN50)**

Min. Installation temperature= -10°C  
 Max. Operation temperature= 95°C  
 $\Delta t = 95 - (-10) = 105^\circ\text{C}$   
 $K = \text{Thermal expansion coefficient for carbon steel pipes} = 0,012\text{mm/m}^\circ\text{C}$   
 $S = 1,05$  (5% safety factor)  
 $H = \text{max. floor height} = 3,3\text{m}$   
 $N = \text{max. floor number} = 10$   
 $\Delta L = \text{total thermal expansion} = K \times \Delta t \times (H \times N) \times s$   
 $\Delta L = 0,012 \times 105 \times 33 \times 1,05 = 43,65\text{mm}$

**Result:** Total expansion of the pipe (44,49mm) must be absorbed by expansion joint that must have min. 44,49mm compression capacity. Using single Ayvaz pipe expansion joint with 50mm (-45/+5) axial movement capacity is sufficient enough to absorb total pipe's expansion.

**Single Expansion Joint for The Buildings Up To 17 Floors**

- Pipe line of the top 3 floors in not necessary to be fixed as the pipe & branch equipment like elbows, tees etc... would be sufficient to absorb the expansion. Similarly, 4 floors from the bottom do not require the use of expansion joint as the main connection at the basement (not fixed) would slide upward and downward to withstand the thermal movement.
- This basically means that the use of expansion joints for the buildings with less than 7 floors is not necessary.
- Thermal movement of the pipes of the buildings up to 17 floors is possible by using single Ayvaz expansion joint.

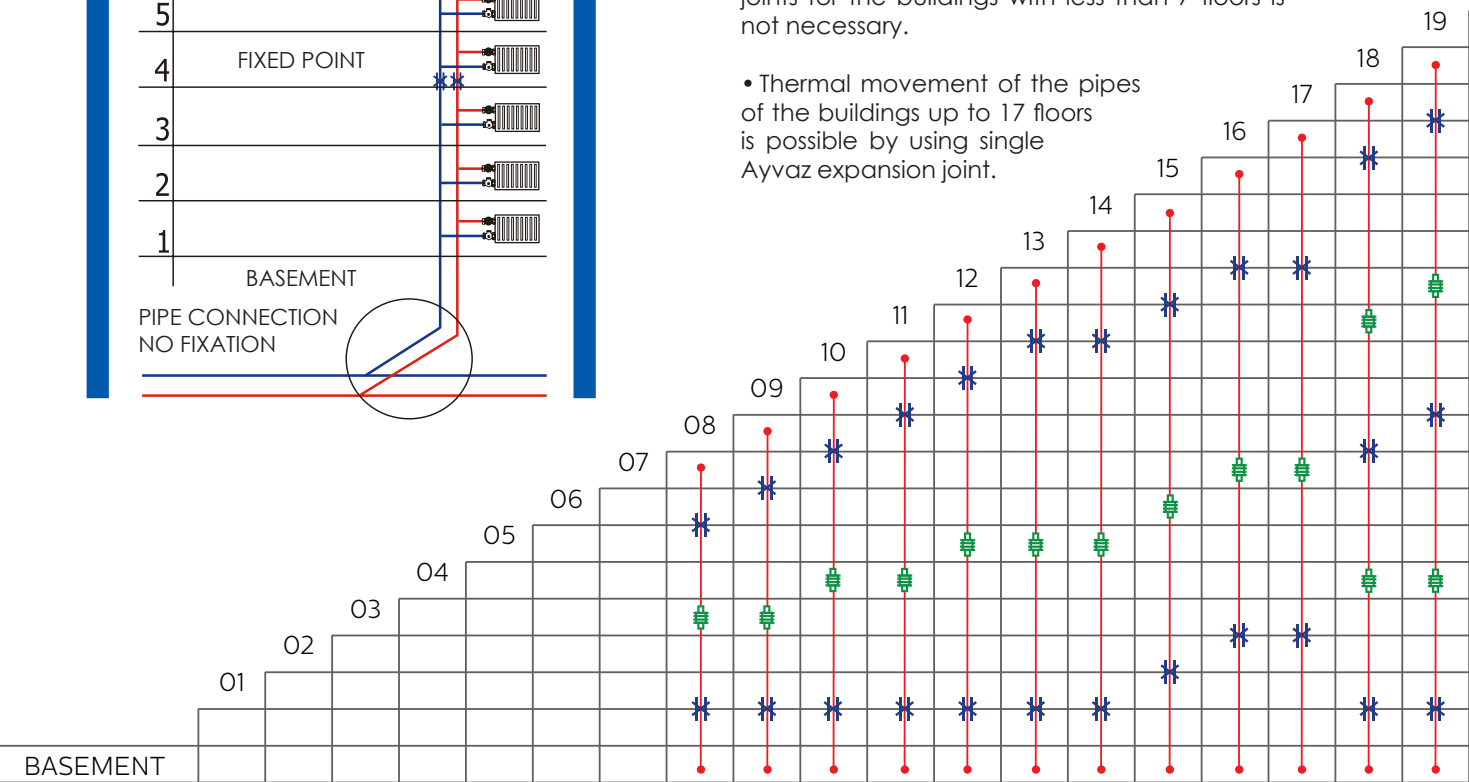

# PIPE EXPANSION JOINTS

## AYVAZ PIPE EXPANSION JOINTS BUILDING INSTALLATION SCHEME

### HEATING LINE FOR CARBON STEEL PIPELINES FOR BUILDINGS WITH 8-40 FLOORS

Dimensions : DN15-DN50  
 Total Axial Mov. Capacity : 50mm (45mm comp/5mm ext.)  
 Max. Operating Pressure : 16 bar  
 Floor Height : 3-3,3m  
 Operating Temperature : 95°C  
 Min. Ambient Temperature : -10°C

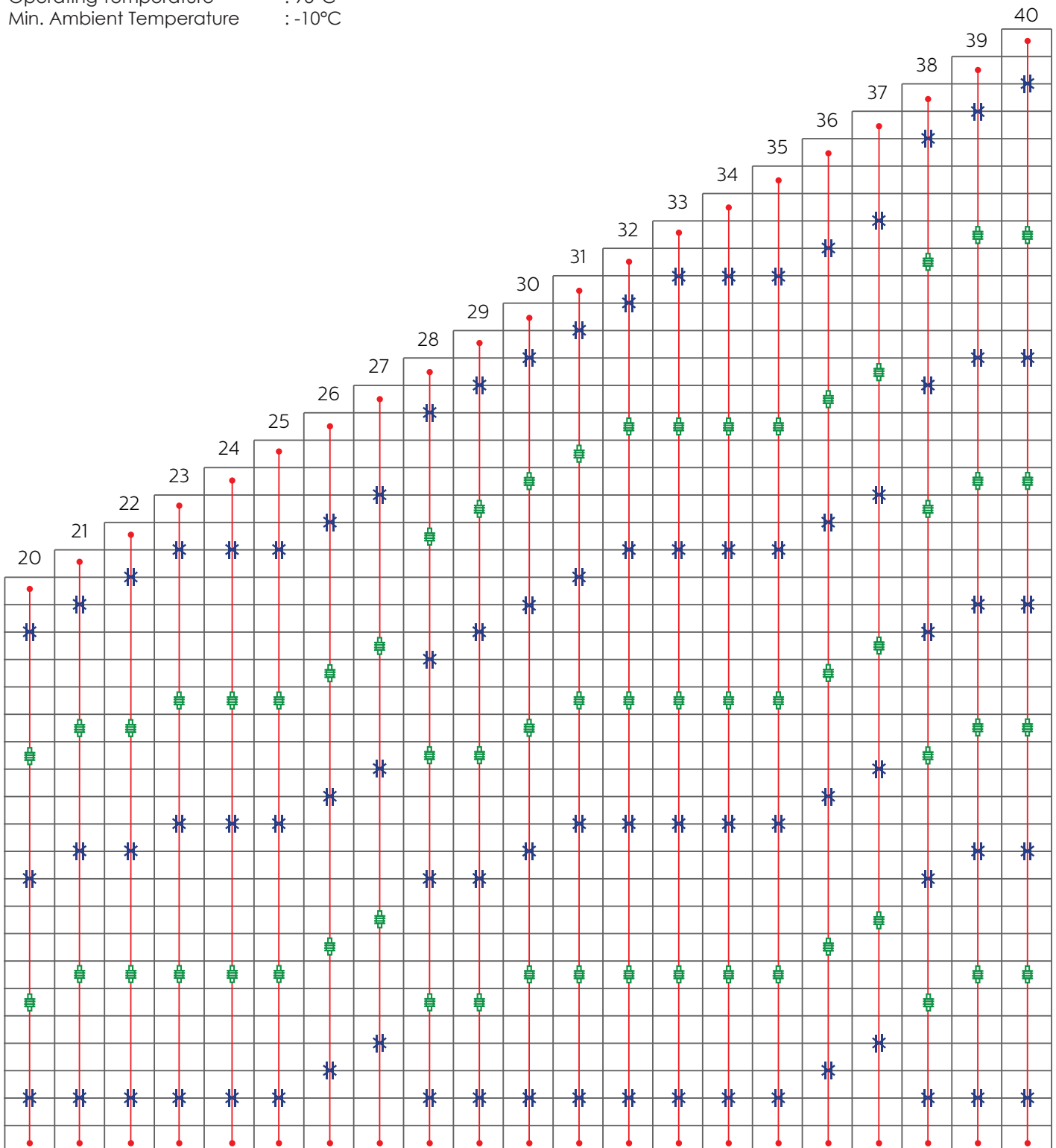

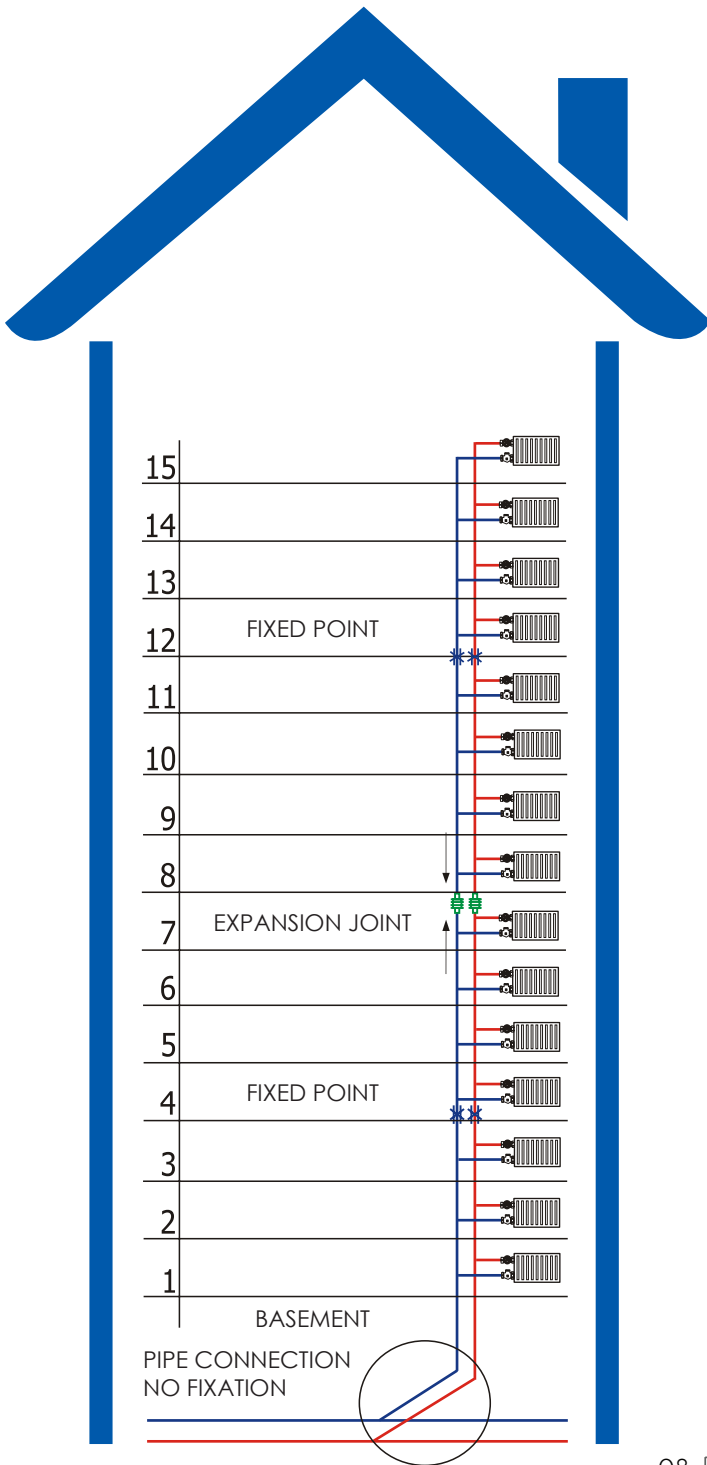

**THERMAL EXTENSION CALCULATION & EXPANSION JOINT SELECTION (DN65-DN150)**

Min. Installation temperature= -10°C  
 Max. Operation temperature= 95°C  
 $\Delta t = 95 - (-10) = 105^\circ\text{C}$   
 $K =$  Thermal expansion coefficient for carbon steel pipes= 0,012mm/m°C  
 $S = 1,05$  (5% safety factor)  
 $H =$  max. floor height= 3,3m  
 $N =$  max. floor number= 8  
 $\Delta =$  total thermal expansion=  $K \times \Delta t \times (H \times N) \times s$   
 $\Delta L = 0,012 \times 105 \times 26,4 \times 1,05 = 34,92\text{mm}$

**Result:** Total expansion of the pipe (34,92mm) must be absorbed by expansion joint that must have min. 34,92mm compression capacity. Using single Ayvaz pipe expansion joint with 50mm (-35/+15) axial movement capacity is sufficient enough to absorb total pipe's expansion.

**Single Expansion Joint for The Buildings Up To 15 Floors**

- Pipe line of the top 3 floors in not necessary to be fixed as the pipe & branch equipment like elbows, tees etc... would be sufficient to absorb the expansion. Similarly, 4 floors from the bottom do not require the use of expansion joint as the main connection at the basement (not fixed) would slide upward and downward to withstand the thermal movement.

- This basically means that the use of expansion joints for the buildings with less than 7 floors is not necessary.

- Thermal movement of the pipes of the buildings up to 15 floors is possible by using single Ayvaz expansion joint.

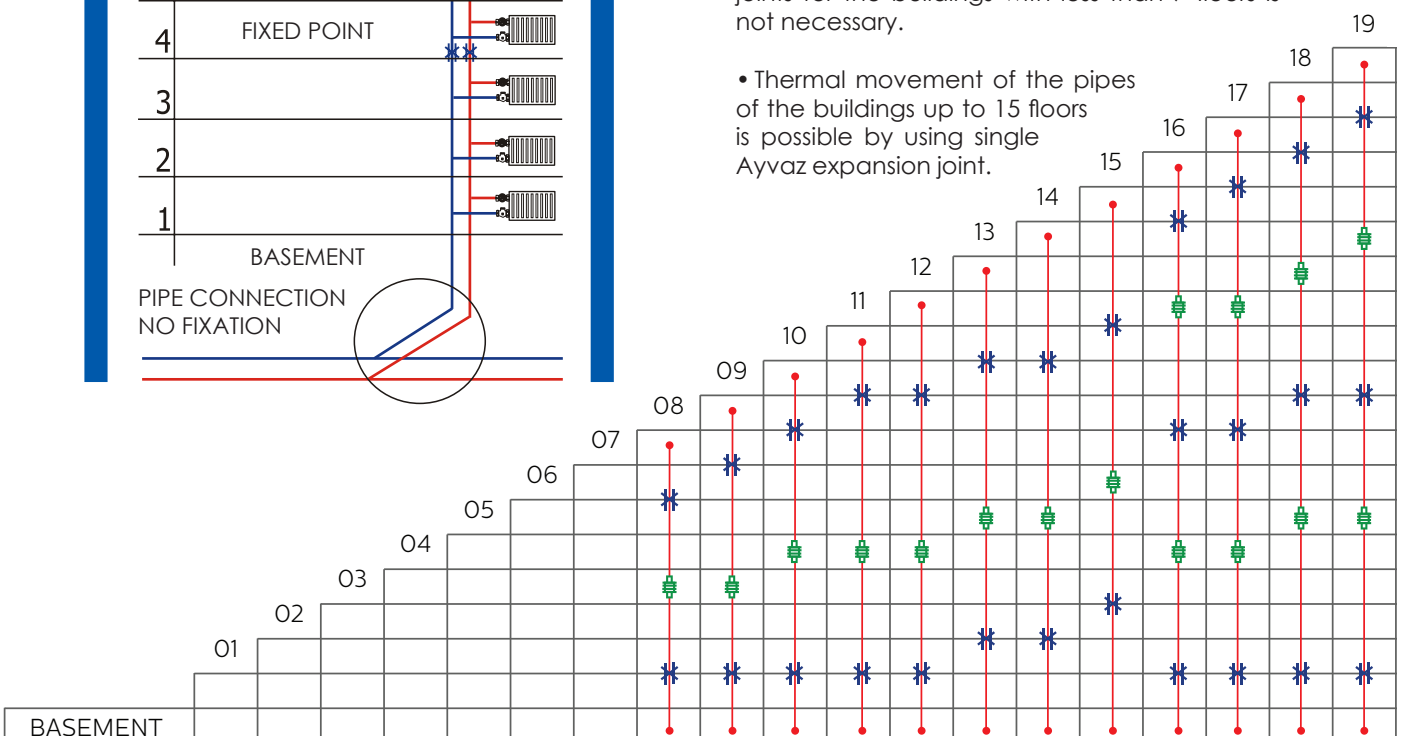



# PIPE EXPANSION JOINTS

## AYVAZ PIPE EXPANSION JOINTS BUILDING INSTALLATION SCHEME

### HEATING LINE FOR CARBON STEEL PIPELINES FOR BUILDINGS WITH 8-40 FLOORS

Dimensions : DN65-DN150  
 Total Axial Mov. Capacity : 50mm (35mm comp/15mm ext.)  
 Max. Operating Pressure : 16 bar  
 Floor Height : 3-3,3m  
 Operating Temperature : 95°C  
 Min. Ambient Temperature : -10°C

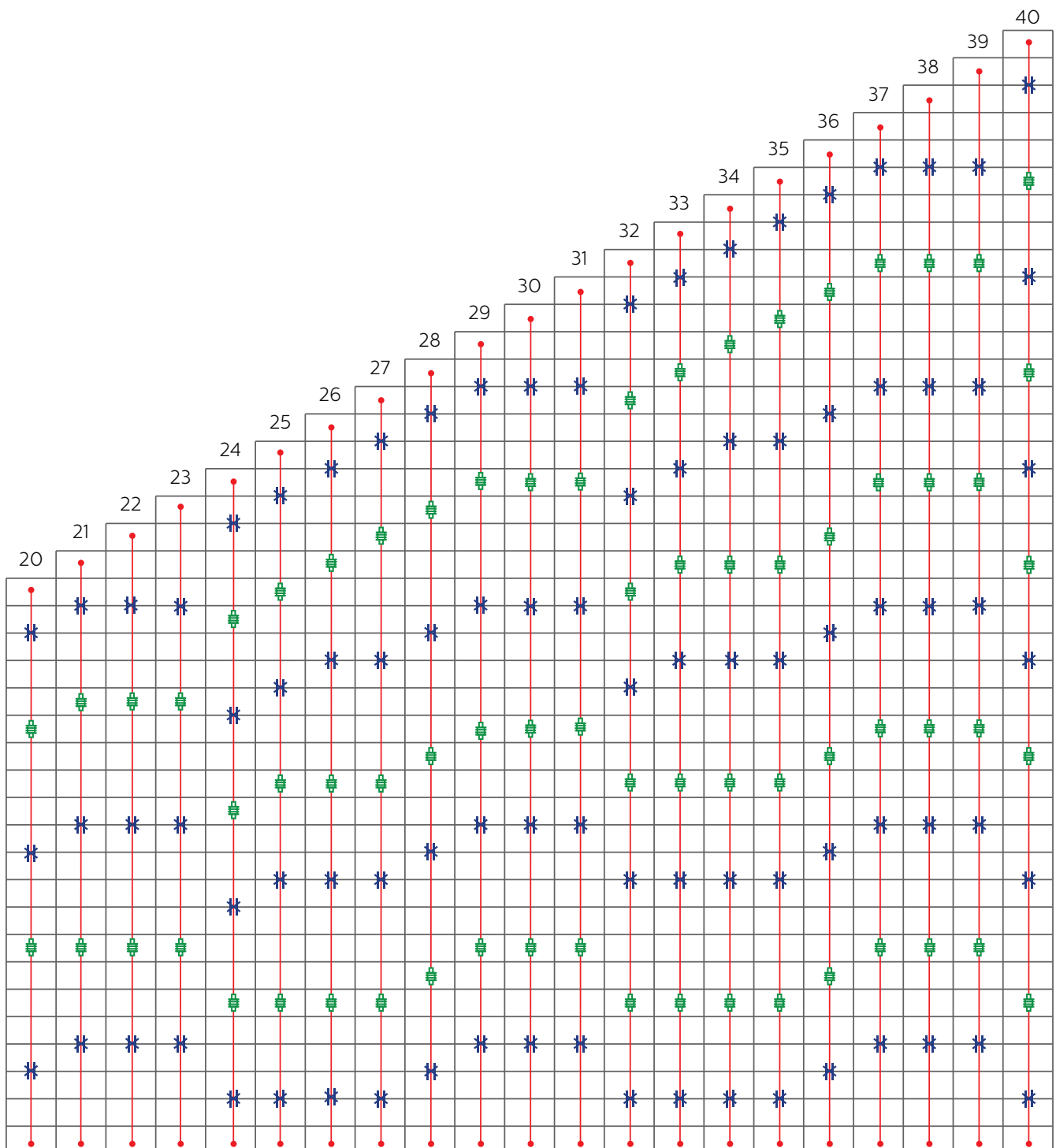

## AXIAL EXPANSION JOINTS - INSTALLATION INSTRUCTIONS

- At all times protect the bellows element itself from damage, such as dents, or scratches due to falling tools or sharp objects, weld splatter, arc strikes, etc.
- Expansion joints provided with lifting lugs should be lifted only by the designated lifting lugs.
- Remove any protective covering from the ends of the expansion joint.
- Check inside of expansion joint for dessicant bags or other material.

### The following steps should be taken prior to installation of the expansion joint

#### 1-Selection of the expansion joint:

Axial expansion joints must be carefully selected according to calculated thermal expansion amount of the connected pipelines. Bellows & connection (weld end, flange etc...) must be decided according to the system temperature, pressure and fluid type.

Springing load features of the expansion joints should be examined before creating fixed points.

Thermal expansion calculation of pipeline & movement capacity of the expansion joints

Expansion amount of the pipeline can easily be calculated with below formula, calculated amount is the key parameter for selecting appropriate expansion joint.

$$\Delta L = \alpha \times \Delta t \times L1$$

$\Delta L$  = Expansion amount (mm)

$\alpha$  = Pipe thermal expansion coefficient (mm/m°C) (To be selected from the pipe material tables )

$L1$  = Pipe length between two fixed points (m)

$\Delta t$  = Temperature difference between fluid and assembly (°C)

Calculated  $\Delta L$  value positive (+) means expansion, negative (-) means compression at pipe section.

Expansion joint's movement capacity should be selected opposite way the pipeline.

(+) If pipeline expands (heating), expansion joint compresses (-)

(-) If pipeline compresses (cooling) expansion joint expands (+)

#### 2- Pipe Sectioning:

Only one expansion joint can be installed between two fixed points.

If the movement amount of the pipeline is too big to be absorbed by one expansion joint, pipeline should be divided in sections by creating additional fixed points.

#### 3-Allocating the Expansion Joints:

Expansion joints should be located as close as possible to the fixed point in order to risk of buckling.

Sliding guide & fixed point allocations should be completed as shown below.

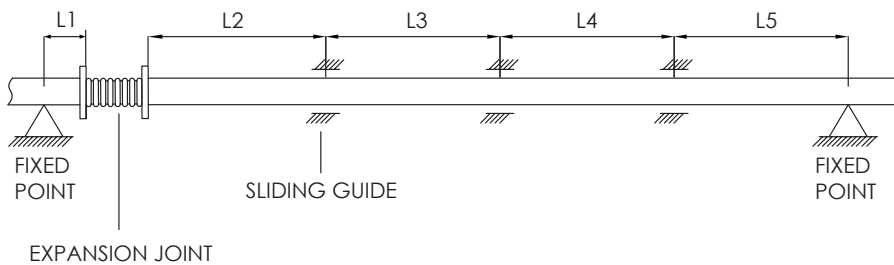

L4 & L5 values should be selected from the guide tables of EJMA code system. (Table 1)

#### 4-Connecting the Expansion Joints

Weld-end expansion joints: The attachment edges of the pipe should be smooth, clean and parallel to each other. Do not use bellows to correct for misalignment of piping unless this has been considered in the design of the expansion joint.

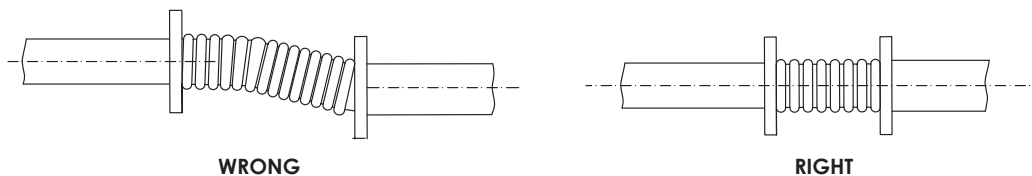

Counter flanges should be placed vertically to the pipe axis.

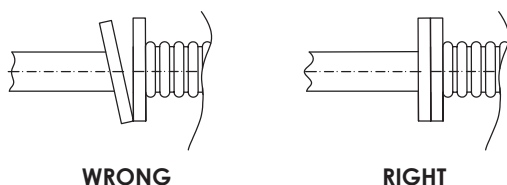

## AXIAL EXPANSION JOINTS - INSTALLATION INSTRUCTIONS

Using the proper electrode, weld the expansion joint to adjacent piping. Damages caused by arc sparks through welding process should be prevented. Bellows must be protected by a wet towel or cloth during the welding.

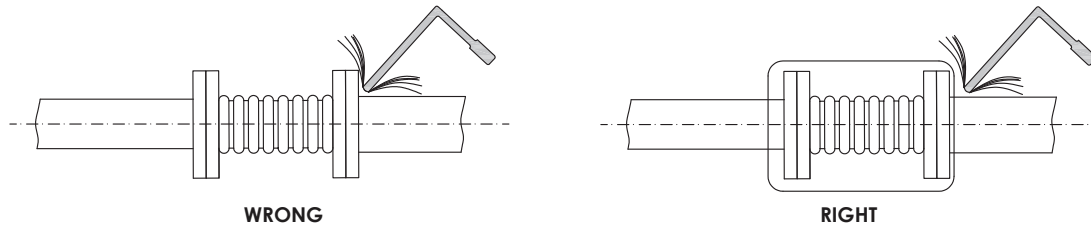

Orient expansion joint flanges so that the bolt holes are aligned with the mating flanges.

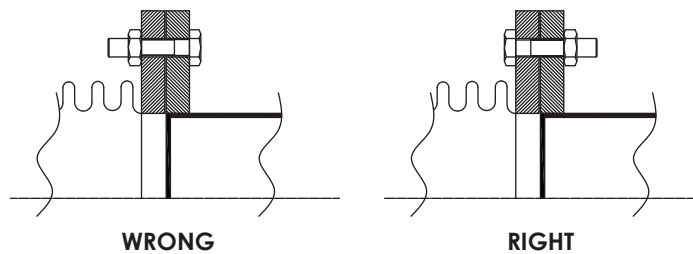

When a flow liner is installed in the expansion joint, orient expansion joint with flow arrow pointing in the direction of flow.

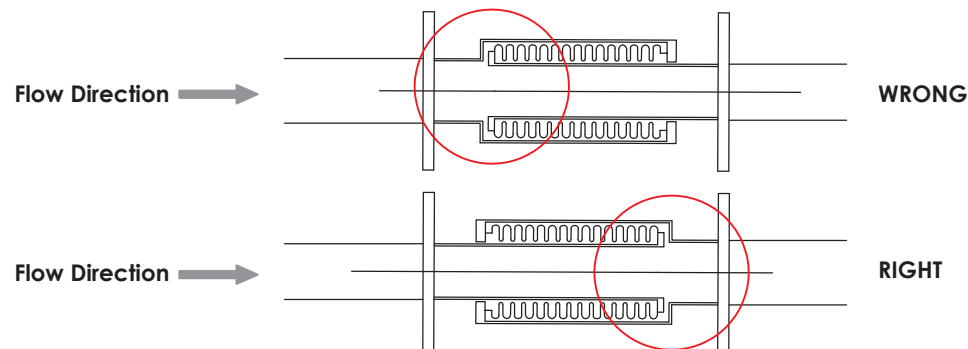

Do not torque the expansion joint to match the bolt holes of the mating flange. This causes torsion on the bellows and will severely reduce the bellows capability during operation and may lead to premature failure of the expansion joint.

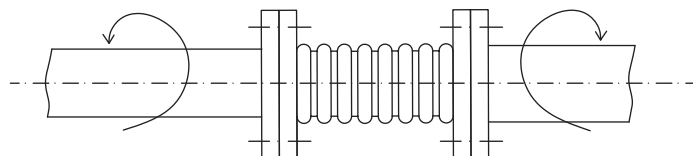



## AXIAL EXPANSION JOINTS - INSTALLATION INSTRUCTIONS

### 5-Pre-setting the Expansion Joints

Expansion joints could be pre-stressed. As the expansion joints are often installed in cold pipelines they may be pre-stressed in order to absorb larger movements.

An example of pre-stressing amount is given below. Half of the total expansion amount may be practically considered. Expansion joint gap in the pipelines should be as big as L+PS. One side of the expansion joint should be assembled to counter flange, other must be assembled via long bolts to be tighten equally.

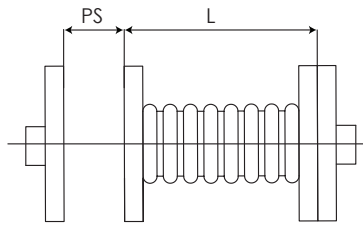

$$PS = \frac{\Delta L}{2} - \Delta L \frac{T_i - T_{min}}{T_{max} - T_{min}}$$

- $\Delta L$  = Expansion amount
- $T_i$  = Ambient temperature
- $T_{min}$  = Minimum temperature
- $T_{max}$  = Maximum temperature

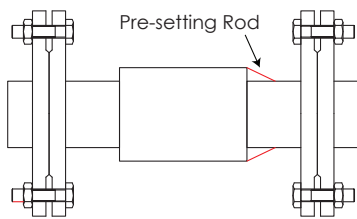

Pre-stressing of externally pressurized expansion joints are done during the production. After the installation of expansion joint, pre-setting rods are taken out and the expansion joint gets ready.

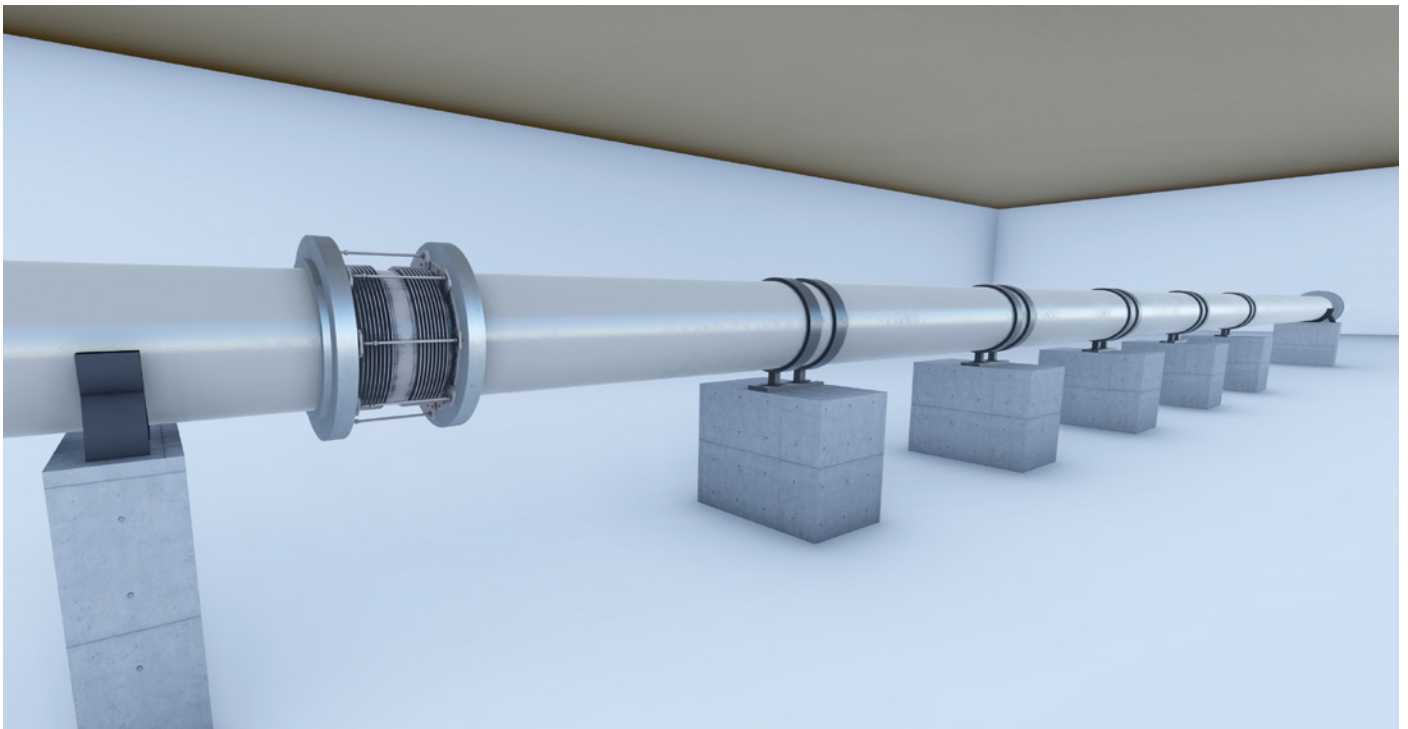

# AXIAL EXPANSION JOINTS - INSTALLATION INSTRUCTIONS

## CALCULATION OF ANCHOR (FIX POINT) LOADS

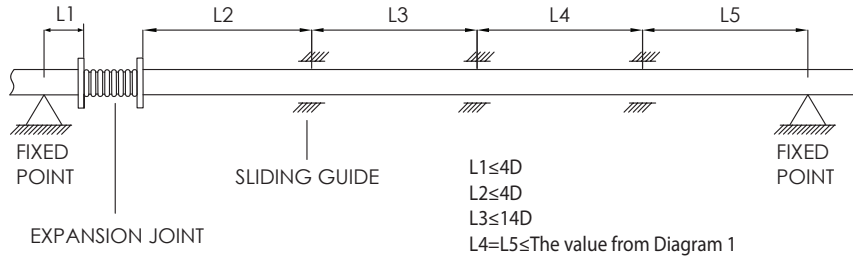

## MAINTENANCE OF EXPANSION JOINTS and SPARE PARTS

Metal Bellows Expansion Joints are maintenance free items, as long as the product selection and installation are done properly. No additional spare part is needed during the lifetime.

Metal Bellows Expansion Joints have been designed to absorb a specified amount of movement by flexing of the thin-gauge convolutions. If proper care is not taken during installation, it may reduce the cycle life and the pressure capacity of the expansion joints which could result in an early failure of the bellows element or damage the piping system.

The following recommendations are included to avoid the most common errors that occur during installation. When in doubt about an installation procedure, contact the manufacturer for clarification before attempting to install the Expansion Joint.

There are two major loads to be calculated in piping systems where expansion joints installed in order to absorb thermal movements.

### 1- PRESSURE THRUST:

Pressure thrust is the most important force encountered in pressurised pipe systems and if ignored or incorrectly calculated, it can have a major impact on the pipe systems and the anchors. Pressure thrust can not be eliminated as long as the axial bellows movement exist in the piping and it must be calculated very carefully.

Bellows usually have a cross-sectional area, which is slightly larger than the pipe diameter due to the height of the convolutions. This is very important as it should be taken into consideration when designing the fix points. The effective cross section is given by the sketch below. Pressure thrust force is calculated by bellows mean diameter multiplied by the maximum system pressure as follows:

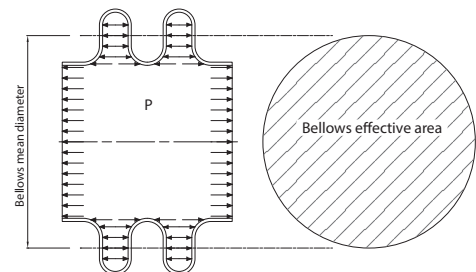

$$F_p = P \times A$$

$F_p$  = Pressure thrust force [N]

$P$  = Pressure [bar]

$A$  = Bellows mean diameter area [mm<sup>2</sup>]

### 2- SPRINGING FORCE:

Flexible bellows can be compared to a steel spring in its flexible motion. The spring rate is an expression of the force required to compress or extend the bellows, or alternately its resistance to deflect, which is another factor to take into account when calculating loads on fix points. The amount of the spring force is dependent on the bellows spring rate and the amount of the bellows movement, which is calculated as follows:

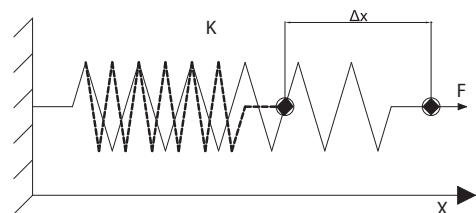

$$F = K \times X$$

$F$  = Force [N]

$K$  = Spring rate [N/mm]

$X$  = Movement [mm]

**Installation Example for X-Pressed Expansion Joints**

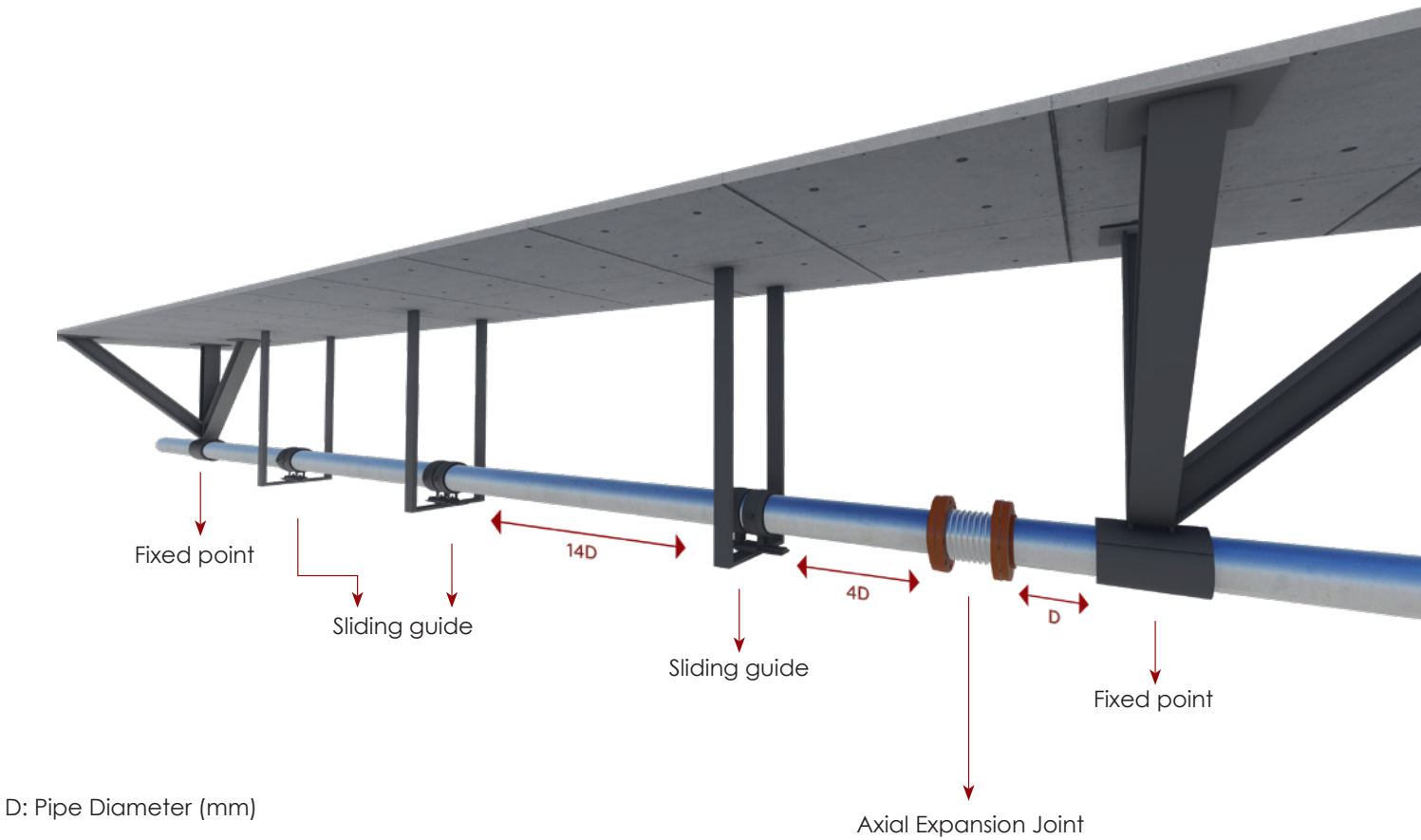
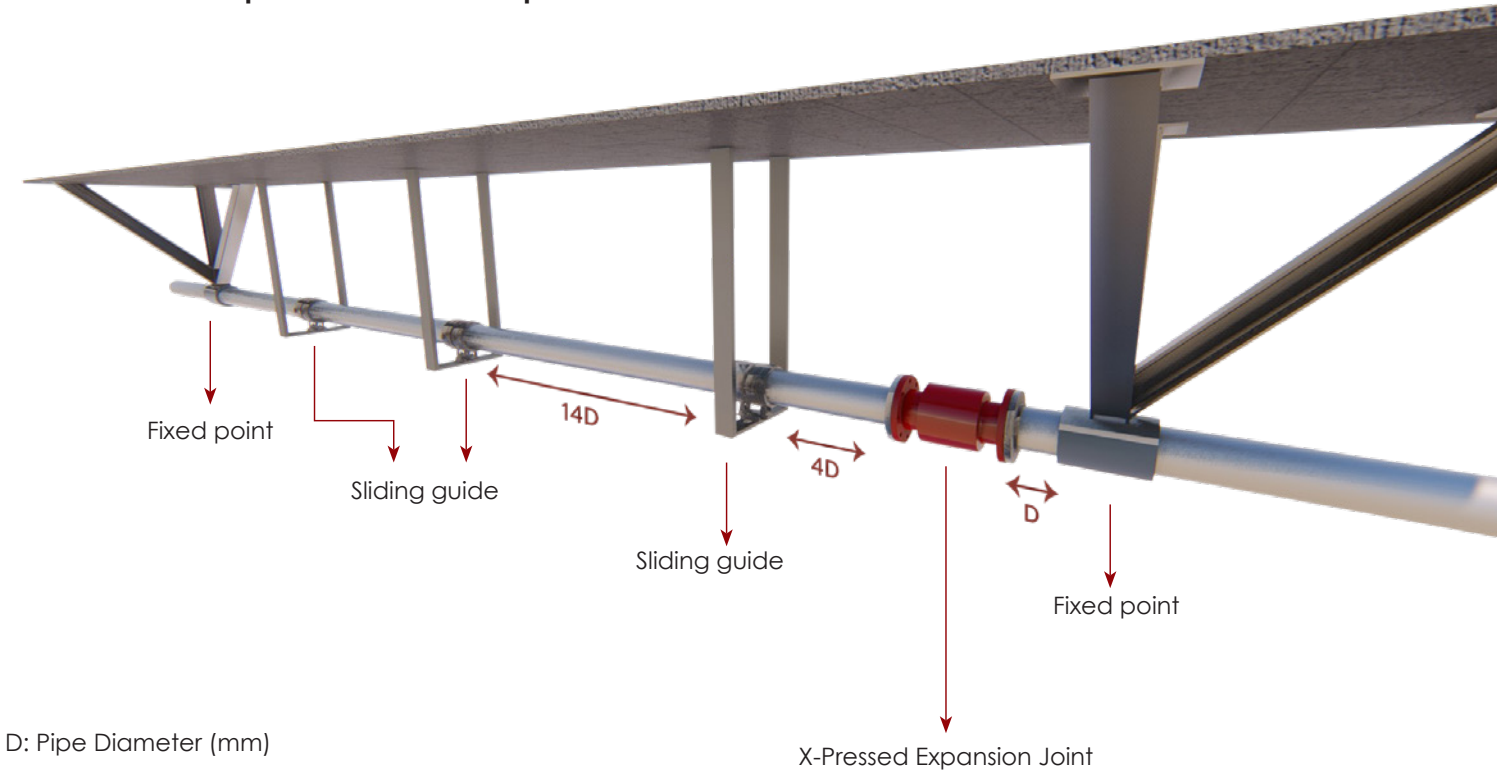

# AXIAL EXPANSION JOINTS - INSTALLATION INSTRUCTIONS

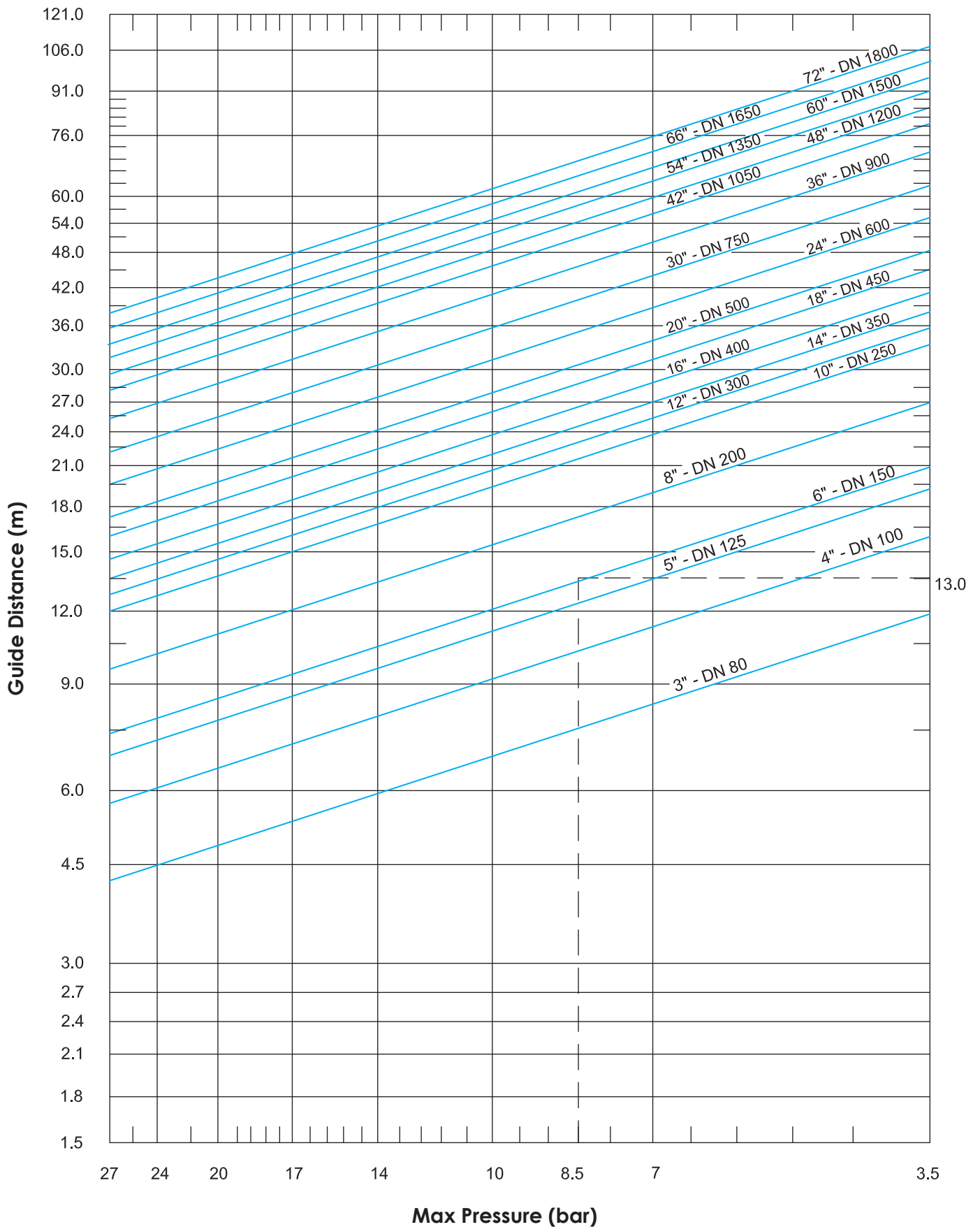



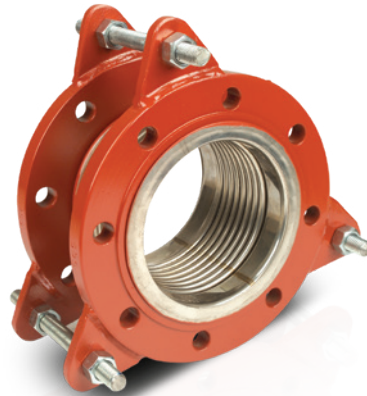

Scan this QR Code



Besides of compensating thermal expansions, metal bellowed expansion joints can provide proper solutions for the problems caused by the system vibration.

**Advantages of Double Double Plied Vibration Absorbers**

- The tie rods are used for pressure thrust forces from the pump are not transferred to the piping
- They have a compact design that reduces the waste of space.
- Performance reliability and increased service life of the pipe system and connected equipment

**Application Areas**

- All piping systems and where vibrations and stresses occur
- Equipment like pumps, compressors, engines, burners etc..
- Heating, climate, ventilation and heat recovery installations
- Gas, water and sewage treatment plants

**DESIGN (EN 14917&EJMA)**

Bellow Material	Stainless Steel AISI 321 (Opt.304,316L,316TI,309)
Connection Types	Fixed and Floating Flanged, Welded Ended & Grooved
Flange Material	PN 16, St.37.2 as standard, the material can be customised on request
Inner Sleeve	Available in stainless steel AISI 321 (Opt. 304,316L,316TI,309) on request
Accessories	Inner sleeve, cover, counter flange, gaskets, insulation etc. are available on request.
Certificates	Material certificate 3.1 according to EN 10204 and /or ASME PED 2014/68/EU Cat.III Mod.H

**Operation Conditions**

Operating Temperature	-10°C/+550°C
Operating Pressure	Standard pressure rating is PN16 Can be produced with different pressure rates PN 2,5-63 PN corresponds to the allowable operating pressure at room temperature

**Important**

We strongly advise against the use of expansion joints and bellows for misalignment. Torsion on bellow parts are not desirable and should be eliminated.

## VIBRATION ABSORBERS

Double Plied Vibration Absorber with rotating flanges			
Type	Movement	Available Sizes (DN)	Pressure Class (PN)
MKTY-30	30 mm (-20/+10)	25-5000	16

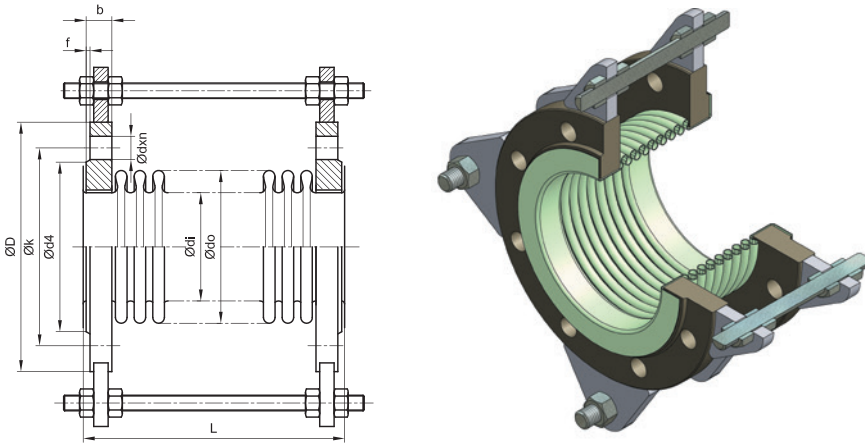

Bellows Information					MKTY-30	
DN	Ødi	Ødo	Effective Bellows Area cm <sup>2</sup>	Axial Spring Rate N/mm	L	Code
DN25	38	48,2	14,58	82,1	110	702.031.103.102
DN32	42,4	55	18,62	49,7	115	702.031.103.104
DN40	48,3	61	23,44	60,8	120	702.031.103.106
DN50	60,3	76	36,46	104,5	110	702.031.103.108
DN65	76,1	95	57,45	87,8	110	702.031.103.110
DN80	88,9	111	78,42	178,9	110	702.031.103.112
DN100	114,3	140	137,09	252,2	115	702.031.103.114
DN125	139,7	164	181,01	320,0	120	702.031.103.116
DN150	168,3	200	266,20	196,4	145	702.031.103.118
DN200	219,1	250	431,86	694,2	140	702.031.103.120
DN250	273	323	697,11	590,0	150	702.031.103.122
DN300	323,9	380	972,37	496,8	150	702.031.103.124

Flange (DIN EN 1092/1) PN 16						
DN	ØD	Øk	Ød4	f	b	Ødxn
DN25	115	85	68	2	16	Ø 14x4
DN32	140	100	78	2	18	Ø 18x4
DN40	150	110	88	3	18	Ø 18x4
DN50	165	125	102	3	20	Ø 18x4
DN65	185	145	122	3	20	Ø 18x4
DN80	200	160	138	3	20	Ø 18x8
DN100	220	180	158	3	22	Ø 18x8
DN125	250	210	188	3	22	Ø 18x8
DN150	285	240	212	3	24	Ø 23x8
DN200	340	295	268	3	26	Ø 23x12
DN250	405	355	320	3	29	Ø 27x12
DN300	460	410	378	4	32	Ø 27x12

Alternative flange dimensions are also possible e.g. according to US standards (ANSI), JIS etc.

\*All dimensions given in the tables are in "mm".

\*\* Subject to technical alterations and deviations resulting from production process without giving any notification.

Reduction Factors for Pressure			
Temperature °C	Reduction Factor Kp	Temperature °C	Reduction Factor Kp
20	1,00	350	0,64
100	0,85	400	0,63
150	0,81	450	0,62
200	0,77	500	0,60
250	0,71	550	0,59
300	0,68	600	0,57

### Pressure reduction factor

The reduction factor is used to define the design pressure [PS] where temperatures exceed 20 °C. It compensates for the decay in material mechanical properties at elevated temperatures. The calculated pressure is lower than the nominal pressure of the standard item.

Calculation:  $PS \leq PN \times Kp$



Scan this QR Code



**Movement Absorption**

Braided expansion joints are constructed with a corrugated inner bellows and braided cover that helps increasing the pressure resistance rating and provides end limitations that annihilate the need for additional control assemblies.

Stainless steel bellows and braiding deliver maximum performance regarding, high pressure and temperature capacity, noise and vibration absorption and overall cyclic service life Unlike rubber expansion joints, stainless steel bellows are not effected by atmospheric damage and UV-radiation especially when used in an outdoor installation.

**Advantages of Using Braided Expansion Joints:**

- The vibration absorbers can withstand high pressure at elevated temperatures
- Reduces vibrations, oscillations, and noise (sound and vibration) from pumps into pipe systems
- Braiding is used for pressure thrust forces from the pump are not transferred to the piping
- They have a compact design that reduces the waste of space.
- Performance reliability and increased service life of the pipe system and connected equipment
- Unlike rubber expansion joints, the vibration absorbers are resistant against ageing, high temperatures and UV-radiation

**DESIGN (EN 14917&EJMA)**

Bellow Material	Stainless Steel AISI 321 (Opt.304,316L,316Ti,309)
Connection Types	Fixed and Floating Flanged, Welded Ended & Grooved
Flange Material	PN 16, St.37.2 as standard, the material can be customised on request
Inner Sleeve	Available in stainless steel AISI 321 (Opt. 304,316L,316Ti,309) on request
Accessories	Inner sleeve, cover, counter flange, gaskets, insulation etc. are available on request.
Certificates	Material certificate 3.1 according to EN 10204 and /or ASME PED 2014/68/EU Cat.III Mod.H

**Operation Conditions**

Operating Temperature-10°C/+550°C  
 Operating PressureStandard pressure rating is PN16  
 PN corresponds to the allowable operating pressure at room temperature

**Important**

We strongly advise against the use of expansion joints and bellows for misalignment. Torsion on bellow parts are not desirable and should be eliminated.

## VIBRATION ABSORBERS

Braided Expansion Joints			
Type	Movement	Available Sizes (DN)	Pressure Class (PN)
ÖKTY-30	-20 mm	32-250	16

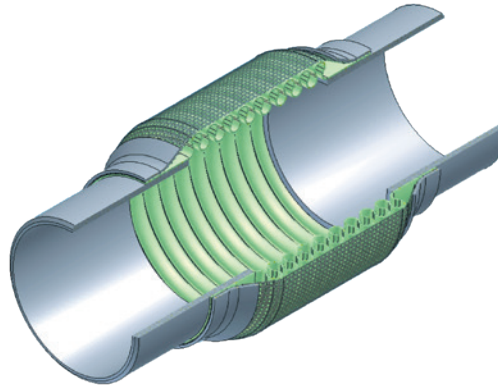
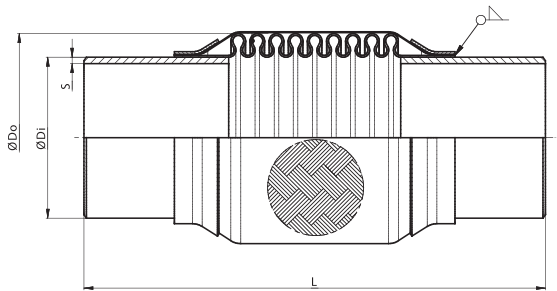

Bellow Information					ÖKTY-30		
DN	Ødi	Ødo	Effective Bellow Area cm <sup>2</sup>	Axial Spring Rate N/mm	S	L	Code
DN32	42,4	55	18,62	49,7	2,6	200	702.351.101.008
DN40	48,3	61	23,44	60,8	2,6	200	702.351.101.010
DN50	60,3	76	36,46	104,5	2,9	200	702.351.101.012
DN65	76,1	95	57,45	87,8	2,9	200	702.351.101.014
DN80	88,9	111	78,42	178,9	3,2	215	702.351.101.016
DN100	114,3	140	137,09	252,2	3,6	215	702.351.101.018
DN125	139,7	164	181,01	320,0	4,0	215	702.351.101.020
DN150	168,3	200	266,20	196,4	4,5	215	702.351.101.022
DN200	219,1	250	431,86	694,2	6,3	215	702.351.101.024
DN250	273	323	697,11	590,0	6,3	250	702.351.101.026

Flange (DIN EN 1092/1) PN 16						
DN	ØD	Øk	Ød4	f	b	Ødxn
DN25	115	85	68	2	16	Ø 14x4
DN32	140	100	78	2	18	Ø 18x4
DN40	150	110	88	3	18	Ø 18x4
DN50	165	125	102	3	20	Ø 18x4
DN65	185	145	122	3	20	Ø 18x4
DN80	200	160	138	3	20	Ø 18x8
DN100	220	180	158	3	22	Ø 18x8
DN125	250	210	188	3	22	Ø 18x8
DN150	285	240	212	3	24	Ø 23x8
DN200	340	295	268	3	26	Ø 23x12
DN250	405	355	320	3	29	Ø 27x12
DN300	460	410	378	4	32	Ø 27x12

\*All dimensions given in the tables are in "mm".

\*\* Subject to technical alterations and deviations resulting from production process without giving any notification.

Alternative flange dimensions are also possible e.g. according to US standards (ANSI), JIS etc.

Reduction Factors for Pressure			
Temperature °C	Reduction Factor Kp	Temperature °C	Reduction Factor Kp
20	1,00	350	0,64
100	0,85	400	0,63
150	0,81	450	0,62
200	0,77	500	0,60
250	0,71	550	0,59
300	0,68	600	0,57

### Pressure reduction factor

The reduction factor is used to define the design pressure [PS] where temperatures exceed 20 °C. It compensates for the decay in material mechanical properties at elevated temperatures. The calculated pressure is lower than the nominal pressure of the standard item.

Calculation:  $PS \leq PN \times Kp$



**Installation Example for Vibration Absorbers**

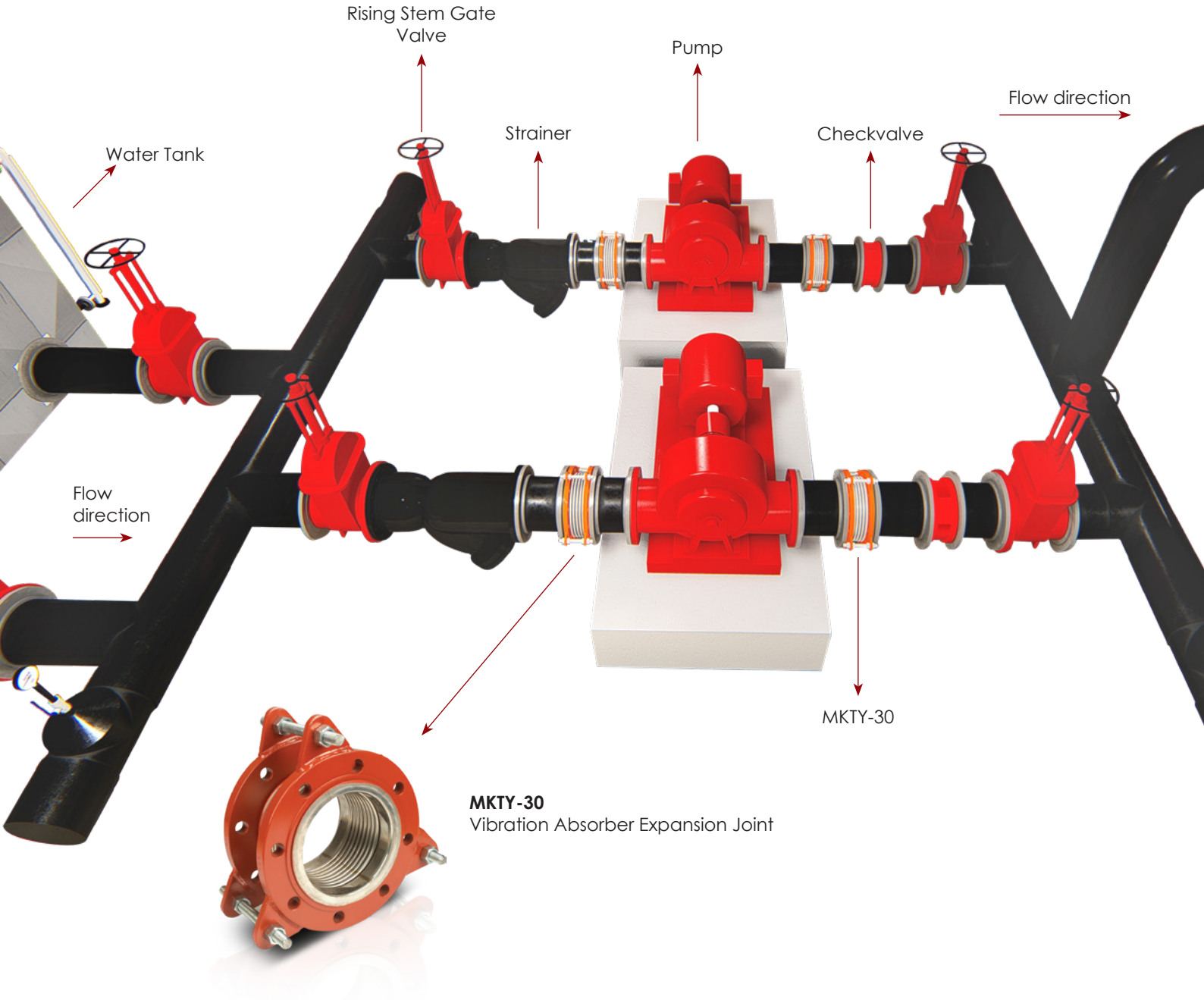

# VIBRATION ABSORBERS

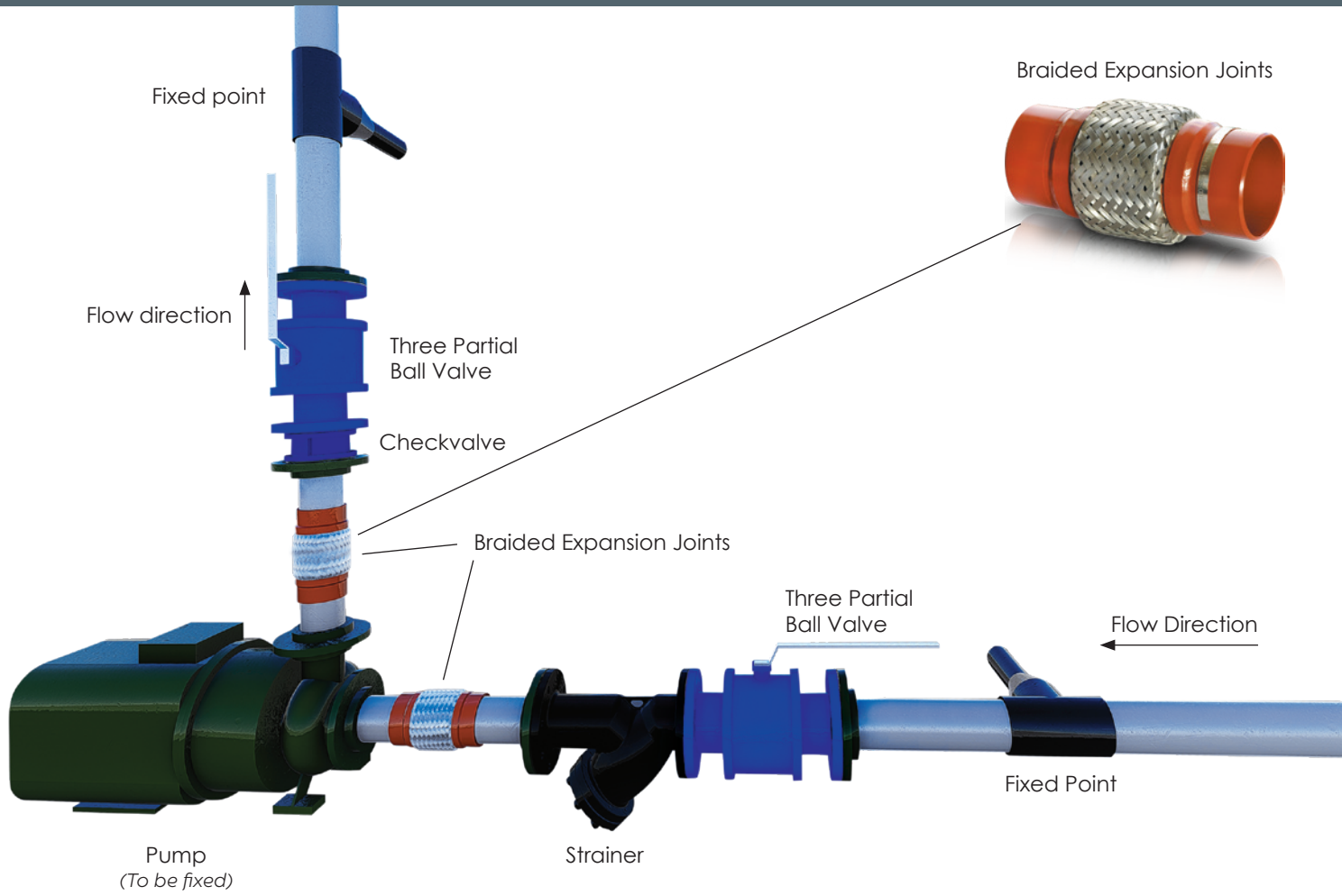

## Example for braided expansion joint installation between two tanks

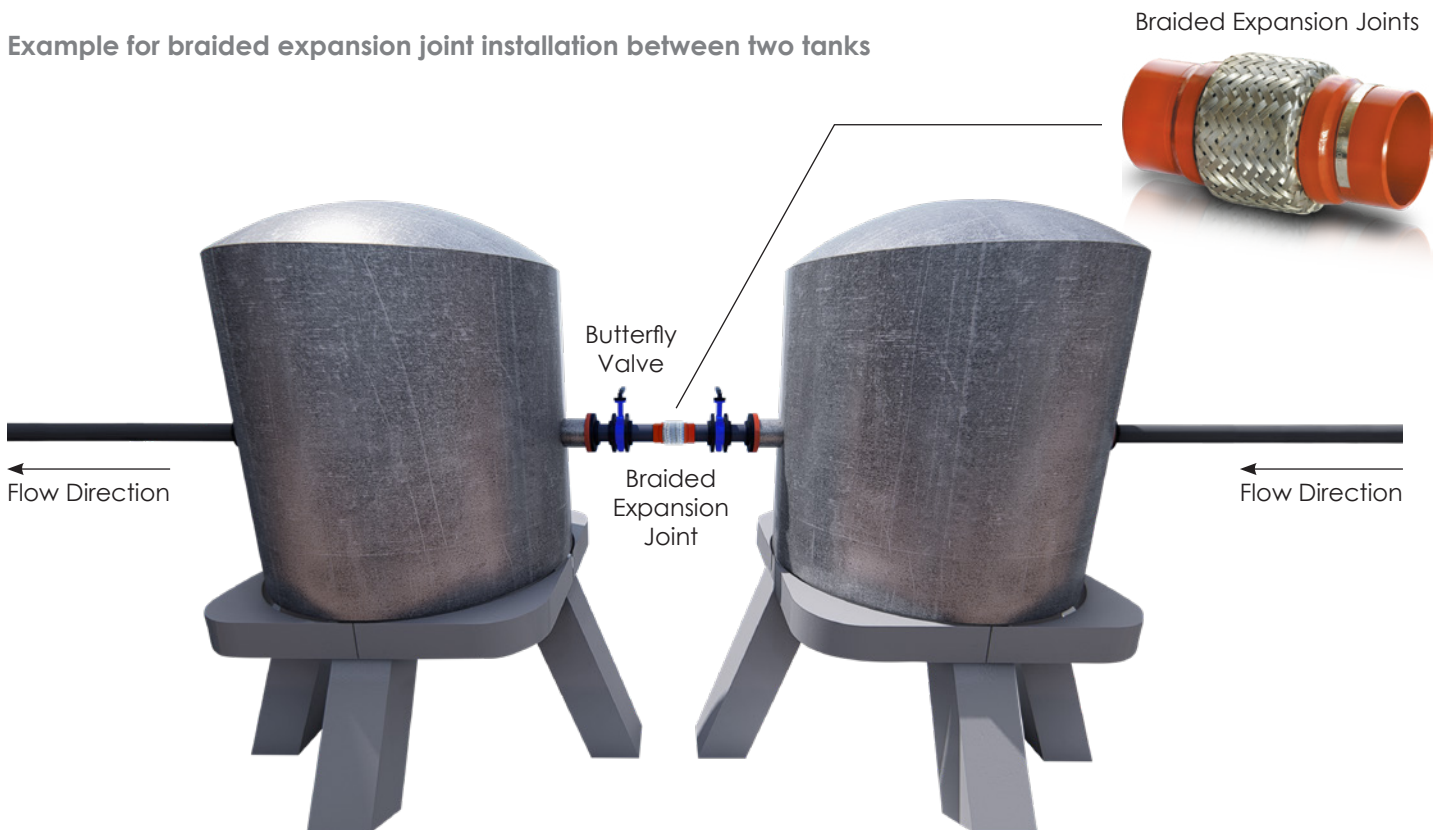

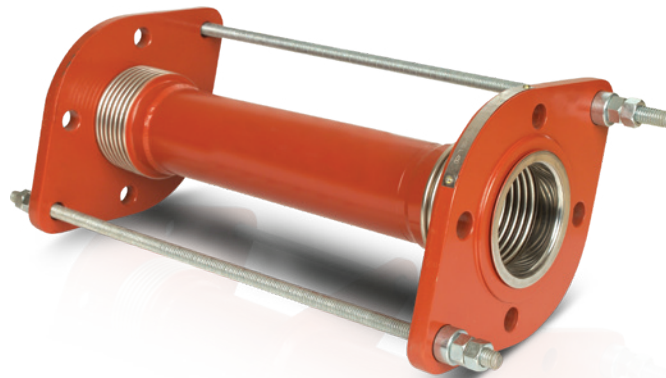

Scan this QR Code



Lateral movement is movement perpendicular to the bellow's longitudinal axis. Thermal movement in pipeline occurred in two directions can be absorbed by using Lateral Expansion Joints. Universal tied expansion joints are made up of two bellows connected each other by an intermediate pipe and a system of tie rods able to withstand the thrust resulted of the internal pressure (restrained).

### Movement Absorption

This type of expansion joints are used to absorb lateral deflections in all planes. Also, with a special positioning of two tie rods at 180 degrees, the expansion becomes able to absorb lateral deflections and angular movements on single plane (2 rods max.) at the same time.

### Advantages of Universal Tied Expansion Joints

- Bellows design according to EJMA coding system.
- Construction according to EN14917 standard.
- Simple Design
- Relatively small load on anchors
- Large lateral movements by single expansion joint

### DESIGN (EN 14917&EJMA)

Bellow Material	Stainless Steel AISI 321 (Opt.304,316L,316Ti,309)
Connection Types	Fixed and Floating Flanged, Welded Ended & Grooved
Flange Material	PN 16, St.37.2 as standard, the material can be customised on request
Inner Sleeve	Available in stainless steel AISI 321 (Opt. 304,316L,316Ti,309) on request
Accessories	Inner sleeve, cover, counter flange, gaskets, insulation etc. are available on request.
Certificates	Material certificate 3.1 according to EN 10204 and /or ASME PED 2014/68/EU Cat.III Mod.H

### Operation Conditions

Operating Temperature	10°C/+550°C
Operating Pressure	Standard pressure rating is PN16 Can be produced with different pressure rates PN 2,5-63 PN corresponds to the allowable operating pressure at room temperature

### Important

We strongly advise against the use of expansion joints and bellows for misalignment. Torsion on bellow parts are not desirable and should be eliminated.

The absorption capacity of lateral expansion joints depend on the convolution number of the bellows on each side of the expansion joint. This amount can also be increased by changing the length of the intermediate pipe. The tie rods are also effective to prevent possible torsion forces.

### Restrained Expansion Joints

Thrust force caused by the internal pressure is needed to be absorbed in order to keep the anchors free from this force in some cases. Restraining parts like tie rods, hinges or gimbals are designed (number & dimensions etc...) according to the pressure thrust. Expansion joints produced with these restraining parts are called restrained expansion joints.

Restrained lateral expansion joints must be free from axial movements and to be adjusted only for lateral movements.

### Application Areas

- HVAC piping lines
- Exhaust Systems
- Vibration absorption
- Industrial process & applications
- Power generation & Energy plants

# UNIVERSAL TIED EXPANSION JOINTS

Type	Lateral Movement		Axial Movement		Pressure Class (PN)	Available Size (DN)
DLTKF-25	±25mm	or	DN15-DN50	±15mm	16	DN25 - DN5000
			DN65-DN300	±30mm		
DLTKF-50	±50mm	or	DN15-DN50	±15mm	16	DN25 - DN5000
			DN65-DN300	±30mm		

\*Given axial movement is only to define the bellows axial capacity, lateral expansion joints should not be used for absorbing axial movements.

\*\*Lateral expansion joints can be converted to axial expansion joints by loosening the tie rods, which is not suggested as they lose the restraining features and become risky against squirm.

\*\*\* Special designed Universal Tied Expansion Joints with customized features are available on request.

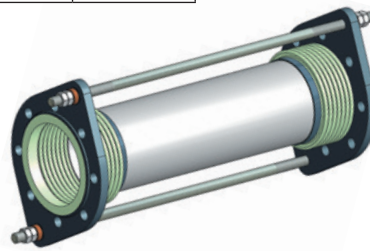
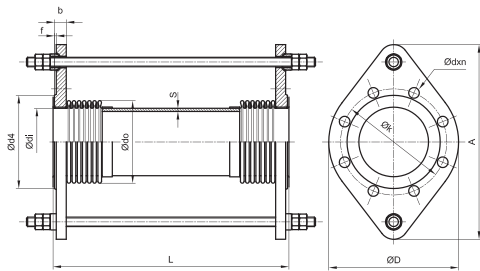

## Pressure reduction factor

The reduction factor is used to define the design pressure [PS] where temperatures exceed 20 °C. It compensates for the decay in material mechanical properties at elevated temperatures. The calculated pressure is lower than the nominal pressure of the standard item.

**Calculation:  $PS \leq PN \times Kp$**

Reduction Factors for Pressure			
Temperature °C	Reduction Factor Kp	Temperature °C	Reduction Factor Kp
20	1,00	350	0,64
100	0,85	400	0,63
150	0,81	450	0,62
200	0,77	500	0,60
250	0,71	550	0,59
300	0,68	600	0,57

Flange (DIN EN 1092/1) PN 16						
DN	ØD	Øk	Ød4	f	b	Ødxn
DN25	115	85	68	2	16	Ø 14x4
DN32	140	100	78	2	18	Ø 18x4
DN40	150	110	88	3	18	Ø 18x4
DN50	165	125	102	3	20	Ø 18x4
DN65	185	145	122	3	20	Ø 18x4
DN80	200	160	138	3	20	Ø 18x8
DN100	220	180	158	3	22	Ø 18x8
DN125	250	210	188	3	22	Ø 18x8
DN150	285	240	212	3	24	Ø 23x8
DN200	340	295	268	3	26	Ø 23x12
DN250	405	355	320	3	29	Ø 27x12
DN300	460	410	378	4	32	Ø 27x12

Alternative flange dimensions are also possible e.g. according to US standards (ANSI), JIS etc.

Bellow				DLTKF-25			DLTKF-50		
DN	Ødi	Ødo	Effective Bellow Area cm <sup>2</sup>	Lateral Spring Rate N/mm	L	Code	Lateral Spring Rate N/mm	L	Code
DN25	38	48,2	14,58	4,0	250	702.070.201.002	2,0	350	702.070.202.002
DN32	42,4	55	18,62	3,0	250	702.070.201.004	1,0	350	702.070.202.004
DN40	48,3	61	23,44	5,0	250	702.070.201.006	2,0	350	702.070.202.006
DN50	60,3	76	36,46	5,0	350	702.070.201.008	3,0	450	702.070.202.008
DN65	76,1	95	57,45	7,0	350	702.070.201.010	4,0	450	702.070.202.010
DN80	88,9	111	78,42	11,0	400	702.070.201.012	6,0	500	702.070.202.012
DN100	114,3	140	137,09	14,0	400	702.070.201.014	8,0	500	702.070.202.014
DN125	139,7	164	181,01	20,0	450	702.070.201.016	9,0	650	702.070.202.016
DN150	168,3	200	266,20	30,0	450	702.070.201.018	12,0	650	702.070.202.018
DN200	219,1	250	431,86	117,0	500	702.070.201.020	53,0	700	702.070.202.020
DN250	273	323	697,11	53,0	600	702.070.201.022	27,0	800	702.070.202.022
DN300	323,9	380	972,37	74,0	750	702.070.201.024	43,0	950	702.070.202.024

\*All dimensions given in the tables are in "mm".

\*\* Subject to technical alterations and deviations resulting from production process without giving any notification.



# UNIVERSAL TIED EXPANSION JOINTS

Type	Lateral Movement		Axial Movement		Pressure Class (PN)	Available Size (DN)
DLTKF-75	±75mm	or	DN15-DN50	±15mm	16	DN25 - DN5000
			DN65-DN300	±30mm		
DLTKF-100	±100mm	or	DN15-DN50	±15mm	16	DN25 - DN5000
			DN65-DN300	±30mm		

\*Given axial movement is only to define the bellows axial capacity, lateral expansion joints should not be used for absorbing axial movements.

\*\*Lateral expansion joints can be converted to axial expansion joints by loosening the tie rods, which is not suggested as they lose the restraining features and become risky against squirm.

\*\*\* Special designed Universal Tied Expansion Joints with customized features are available on request.

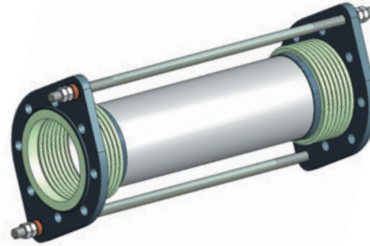
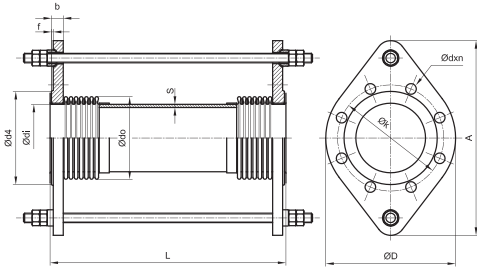

## Pressure reduction factor

The reduction factor is used to define the design pressure [PS] where temperatures exceed 20 °C. It compensates for the decay in material mechanical properties at elevated temperatures. The calculated pressure is lower than the nominal pressure of the standard item.

**Calculation:  $PS \leq PN \times Kp$**

Reduction Factors for Pressure			
Temperature °C	Reduction Factor Kp	Temperature °C	Reduction Factor Kp
20	1,00	350	0,64
100	0,85	400	0,63
150	0,81	450	0,62
200	0,77	500	0,60
250	0,71	550	0,59
300	0,68	600	0,57

Flange (DIN EN 1092/1) PN 16						
DN	ØD	Øk	Ød4	f	b	Ødkn
DN25	115	85	68	2	16	Ø 14x4
DN32	140	100	78	2	18	Ø 18x4
DN40	150	110	88	3	18	Ø 18x4
DN50	165	125	102	3	20	Ø 18x4
DN65	185	145	122	3	20	Ø 18x4
DN80	200	160	138	3	20	Ø 18x8
DN100	220	180	158	3	22	Ø 18x8
DN125	250	210	188	3	22	Ø 18x8
DN150	285	240	212	3	24	Ø 23x8
DN200	340	295	268	3	26	Ø 23x12
DN250	405	355	320	3	29	Ø 27x12
DN300	460	410	378	4	32	Ø 27x12

Alternative flange dimensions are also possible e.g. according to US standards (ANSI), JIS etc.

Bellow				DLTKF-75			DLTKF-100		
DN	Ødi	Ødo	Effective Bellow Area cm <sup>2</sup>	Lateral Spring Rate N/mm	L	Code	Lateral Spring Rate N/mm	L	Code
DN25	38	48,2	14,58	1,0	450	702.070.203.002	1,0	550	702.070.204.002
DN32	42,4	55	18,62	1,0	450	702.070.203.004	1,0	550	702.070.204.004
DN40	48,3	61	23,44	1,0	450	702.070.203.006	1,0	550	702.070.204.006
DN50	60,3	76	36,46	2,0	550	702.070.203.008	1,0	650	702.070.204.008
DN65	76,1	95	57,45	2,0	550	702.070.203.010	2,0	650	702.070.204.010
DN80	88,9	111	78,42	4,0	600	702.070.203.012	3,0	700	702.070.204.012
DN100	114,3	140	137,09	5,0	600	702.070.203.014	8,0	700	702.070.204.014
DN125	139,7	164	181,01	6,0	750	702.070.203.016	5,0	850	702.070.204.016
DN150	168,3	200	266,20	9,0	750	702.070.203.018	9,0	850	702.070.204.018
DN200	219,1	250	431,86	39,0	700	702.070.203.020	30,0	900	702.070.204.020
DN250	273	323	697,11	21,0	800	702.070.203.022	17,0	1000	702.070.204.022
DN300	323,9	380	972,37	35,0	1050	702.070.203.024	35,0	1150	702.070.204.024

\*All dimensions given in the tables are in "mm".

\*\* Subject to technical alterations and deviations resulting from production process without giving any notification.

# UNIVERSAL TIED EXPANSION JOINTS

Type	Lateral Movement		Axial Movement	Pressure Class (PN)	Available Size (DN)	
DLTKKB-25	±25mm	or	DN15-DN50	±15mm	16	DN25 - DN5000
			DN65-DN300	±30mm		
DLTKKB-50	±50mm	or	DN15-DN50	±15mm	16	DN25 - DN5000
			DN65-DN300	±30mm		

\*Given axial movement is only to define the bellows axial capacity, lateral expansion joints should not be used for absorbing axial movements.

\*\*Lateral expansion joints can be converted to axial expansion joints by loosening the tie rods, which is not suggested as they loose the restraining features and become risky against squirm.

\*\*\* Special designed Universal Tied Expansion Joints with customized features are available on request.

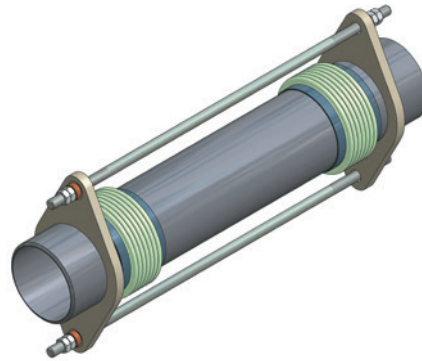
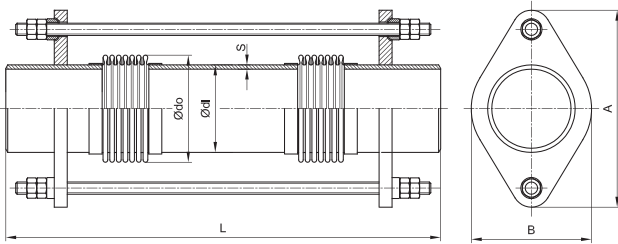

Bellow				DLTKKB-25			DLTKKB-50		
DN	Ødi	Ødo	Effective Bellow Area cm <sup>2</sup>	Lateral Spring Rate N/mm	L	Code	Lateral Spring Rate N/mm	L	Code
DN25	38	48,2	14,58	4,0	540	702.070.101.002	2,0	640	702.070.102.002
DN32	42,4	55	18,62	3,0	540	702.070.101.004	1,0	640	702.070.102.004
DN40	48,3	61	23,44	5,0	540	702.070.101.006	2,0	640	702.070.102.006
DN50	60,3	76	36,46	5,0	610	702.070.101.008	3,0	710	702.070.102.008
DN65	76,1	95	57,45	7,0	610	702.070.101.010	4,0	710	702.070.102.010
DN80	88,9	111	78,42	11,0	660	702.070.101.012	6,0	760	702.070.102.012
DN100	114,3	140	137,09	14,0	660	702.070.101.014	8,0	760	702.070.102.014
DN125	139,7	164	181,01	20,0	700	702.070.101.016	9,0	900	702.070.102.016
DN150	168,3	200	266,20	30,0	700	702.070.101.018	12,0	900	702.070.102.018
DN200	219,1	250	431,86	117,0	750	702.070.101.020	53,0	950	702.070.102.020
DN250	273	323	697,11	53,0	850	702.070.101.022	27,0	1050	702.070.102.022
DN300	323,9	380	972,37	74,0	1000	702.070.101.024	43,0	1200	702.070.102.024

\*All dimensions given in the tables are in "mm".

\*\* Subject to technical alterations and deviations resulting from production process without giving any notification.

Reduction Factors for Pressure			
Temperature °C	Reduction Factor Kp	Temperature °C	Reduction Factor Kp
20	1,00	350	0,64
100	0,85	400	0,63
150	0,81	450	0,62
200	0,77	500	0,60
250	0,71	550	0,59
300	0,68	600	0,57

## Pressure reduction factor

The reduction factor is used to define the design pressure [PS] where temperatures exceed 20 °C. It compensates for the decay in material mechanical properties at elevated temperatures. The calculated pressure is lower than the nominal pressure of the standard item.

Calculation:  $PS \leq PN \times Kp$

# UNIVERSAL TIED EXPANSION JOINTS

Type	Lateral Movement		Axial Movement		Pressure Class (PN)	Available Size (DN)
DLTKKB-75	±75mm	or	DN15-DN50	±15mm	16	DN25 - DN5000
			DN65-DN300	±30mm		
DLTKKB-100	±100mm	or	DN15-DN50	±15mm	16	DN25 - DN5000
			DN65-DN300	±30mm		

\*Given axial movement is only to define the bellows axial capacity, lateral expansion joints should not be used for absorbing axial movements.

\*\*Lateral expansion joints can be converted to axial expansion joints by loosening the tie rods, which is not suggested as they lose the restraining features and become risky against squirm.

\*\*\* Special designed Universal Tied Expansion Joints with customized features are available on request.

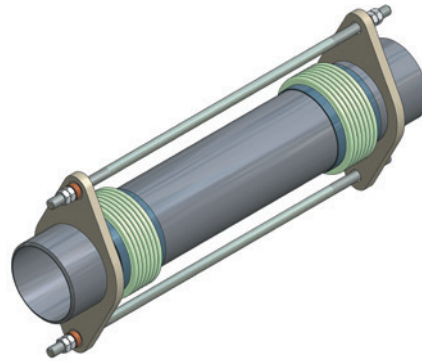
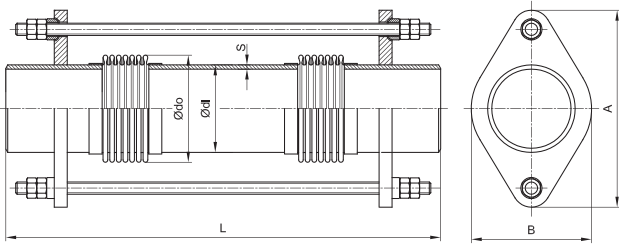

Bellow				DLTKKB-75			DLTKKB-100		
DN	Ødi	Ødo	Effective Bellow Area cm <sup>2</sup>	Lateral Spring Rate N/mm	L	Code	Lateral Spring Rate N/mm	L	Code
DN25	38	48,2	14,58	1,0	740	702.070.103.002	1,0	840	702.070.104.002
DN32	42,4	55	18,62	1,0	740	702.070.103.004	1,0	840	702.070.104.004
DN40	48,3	61	23,44	1,0	740	702.070.103.006	1,0	840	702.070.104.006
DN50	60,3	76	36,46	2,0	810	702.070.103.008	1,0	910	702.070.104.008
DN65	76,1	95	57,45	2,0	810	702.070.103.010	2,0	910	702.070.104.010
DN80	88,9	111	78,42	4,0	860	702.070.103.012	3,0	960	702.070.104.012
DN100	114,3	140	137,09	5,0	860	702.070.103.014	8,0	960	702.070.104.014
DN125	139,7	164	181,01	6,0	1000	702.070.103.016	5,0	1100	702.070.104.016
DN150	168,3	200	266,20	9,0	1000	702.070.103.018	9,0	1100	702.070.104.018
DN200	219,1	250	431,86	39,0	1050	702.070.103.020	30,0	1150	702.070.104.020
DN250	273	323	697,11	21,0	1150	702.070.103.022	17,0	1250	702.070.104.022
DN300	323,9	380	972,37	35,0	1300	702.070.103.024	35,0	1400	702.070.104.024

\*All dimensions given in the tables are in "mm".

\*\* Subject to technical alterations and deviations resulting from production process without giving any notification.

Reduction Factors for Pressure			
Temperature °C	Reduction Factor Kp	Temperature °C	Reduction Factor Kp
20	1,00	350	0,64
100	0,85	400	0,63
150	0,81	450	0,62
200	0,77	500	0,60
250	0,71	550	0,59
300	0,68	600	0,57

## Pressure reduction factor

The reduction factor is used to define the design pressure [PS] where temperatures exceed 20 °C. It compensates for the decay in material mechanical properties at elevated temperatures. The calculated pressure is lower than the nominal pressure of the standard item.

Calculation:  $PS \leq PN \times Kp$

## INSTALLATION OF DILATATION EXPANSION JOINT WITH LIMIT RODS

During a seismic motion, the pipelines are affected from the unforecasted movements just like the buildings. The most important points to be protected during such an event is the dilatation points.

### What is Dilatation Point?

Modern buildings are consisted of multiple independent sections the areas between two building is called dilatation point. The pipelines are goes through from one building to another should be protected with seismic motion absorption joints.

### Why are the dilatation points so important?

Because of the different arcitectural and constructional features as well as the geological characteristics of the bases, the movements of buildings may differ. So, pipeline costructors should use 3D motion absorber at these areas. Appropriate expansion joints must be installed to the pipelines underneath the dilatation points.

### Purpose of Dilatation Expansion Joints

- This type of expansion are able to make movement in all three axis.
- The movement amount must be selected according to building displacement amount.
- Rods on the expansion joints are not used for making the joints restrained againts the pressure thrust, only for limiting the axial movement capacity.
- Axial movement of the expansion joint could be adjsuted by the road openings.

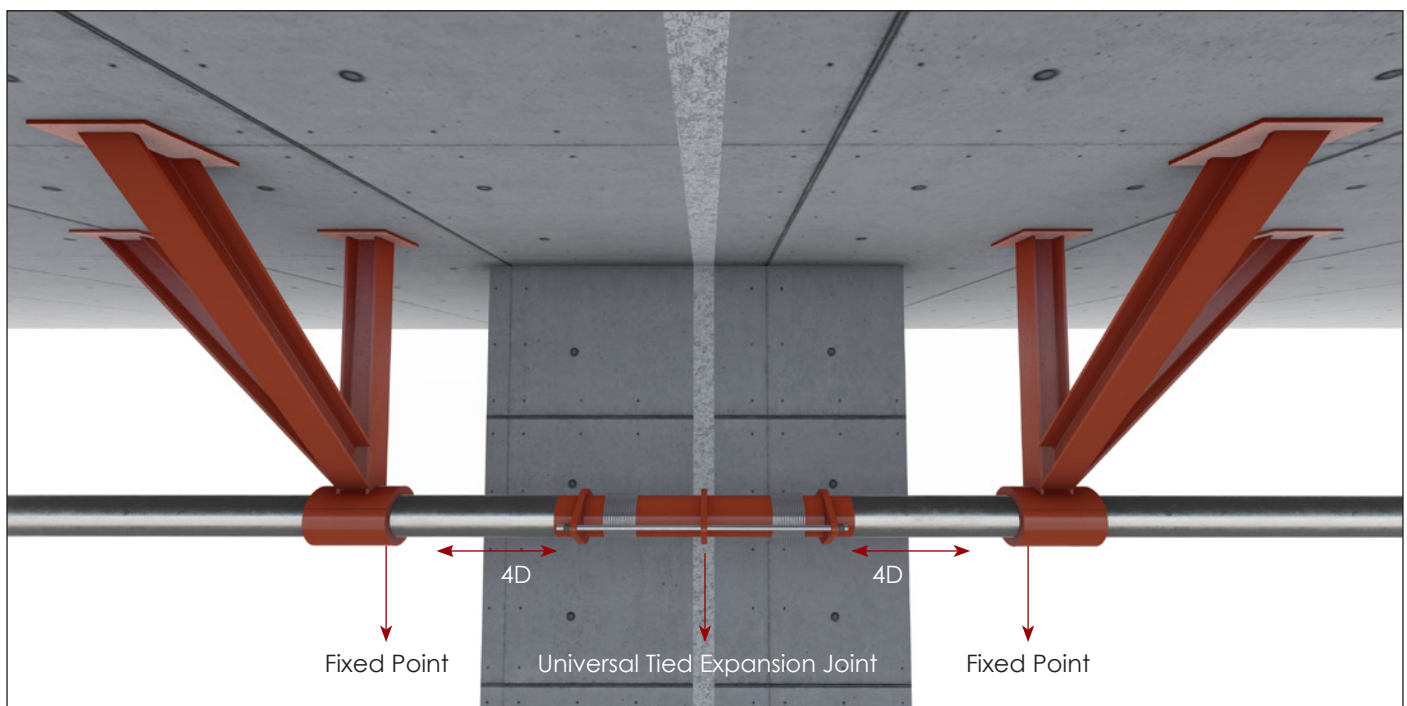

A gap which is equal to the movement amount of the expansion joint should be left between the joint and the construction elements like walls and ceiling. Both ends of the expansion joint should be fixed to each building with the distance of  $4D$

### Example

In case of a dilatation expansion joint with 100mm lateral deflection capacity to be installed at the dilatation point of 2 buildings, the expansion joint should be placed in minimum 100mm distance from the ceiling, each ends should be fixed within 400mm.





Scan this QR Code



Gimbal type expansion joints are designed to permit angular rotation in any plane by the use of two pairs of hinges affixed to a common floating gimbal ring. Simply, a double gimbal expansion joint is consisted of two single gimbal expansion joints and an intermediate pipe connects them each other. The advantage of this arrangement is the ability to absorb a large lateral movement in any plane at each end.

### Movement Absorption & Seismic Movement

Classical double gimbal expansion joints are used to absorb lateral & angular deflections in all planes. The gimbals of this expansion joints are designed as to withstand against pressure thrust and they are called restrained type expansion joints. The amount of lateral deflection depends on the convolution number of the bellows on each side and the length of the intermediate pipe.

Standard range of Ayvaz double gimbal expansion joints are designed mostly for fire protection lines where the deflections are not caused by thermal movements but seismic movements. In order to absorb the axial movements caused by the seismic movements, Ayvaz standard range expansion joints are finished with an axial movement capacity which is limited by the slot gap on the gimbals.

### Advantages of Double Gimbal Seismic Expansion Joints

- Protects the pipeline systems against collapse and breakages by compensating seismic motions (earthquake) and large lateral and angular movements.
- FM approval for the safety features to be used at fire protection pipelines.
- Bellows design according to EJMA coding system.
- Construction according to EN14917 standard.
- Large lateral movements by single expansion joint.

### Application Areas

- Fire Protection | HVAC piping lines

### DESIGN (EN 14917&EJMA)

Bellow Material	Stainless Steel AISI 321 (opt.304,316L,316Ti,309)
Connection Types	Fixed and Floating Flanged, Welded Ended & Grooved
Flange Material	PN 16, St.37.2 as standard, the material can be customised on request
Inner Sleeve	Available in stainless steel AISI 321 (opt.304,316L,316Ti,309) on request
Accessories	Inner sleeve, cover, counter flange, gaskets, insulation etc. are available on request.
Certificates	FM approval, Class 1920 PED 2014/68/EU Cat.III Mod.H Material certificate 3.1 according to EN 10204 and /or ASME

### Operation Conditions

Operating Temperature	-10°C/+550°C
Operating Pressure	175 psi & 250 psi Can be produced with different pressure rates PN 2,5-63

### Important

For detailed information, get in contact with Ayvaz's expert sales team. We strongly advise against the use of expansion joints and bellows for misalignment. Torsion on bellow parts are not desirable and should be eliminated.

# DOUBLE GIMBAL EXPANSION JOINTS

Double Gimbal Expansion Joints, Flanged				
Type	Lateral Movement	Axial Movement	Pressure Class	Available Sizes (DN)
SISKF-50	±50mm	±50mm	175 psi 250 psi	DN25-DN300 (FM approved) DN350-DN5000 (on request)
SISKF-100	±100mm	±50mm		
SISKF-150	±150mm	±50mm		
SISKF-200	±200mm	±50mm		

Flange (DIN EN 1092/1) PN 16						
DN	ØD	Øk	Ød4	f	b	Ødxn
DN25	115	85	68	2	16	Ø 14x4
DN32	140	100	78	2	18	Ø 18x4
DN40	150	110	88	3	18	Ø 18x4
DN50	165	125	102	3	20	Ø 18x4
DN65	185	145	122	3	20	Ø 18x4
DN80	200	160	138	3	20	Ø 18x8
DN100	220	180	158	3	22	Ø 18x8
DN125	250	210	188	3	22	Ø 18x8
DN150	285	240	212	3	24	Ø 23x8
DN200	340	295	268	3	26	Ø 23x12
DN250	405	355	320	3	29	Ø 27x12
DN300	460	410	378	4	32	Ø 27x12

\* Special designed Double Gimbal type Expansion Joints with customized features are available on request.

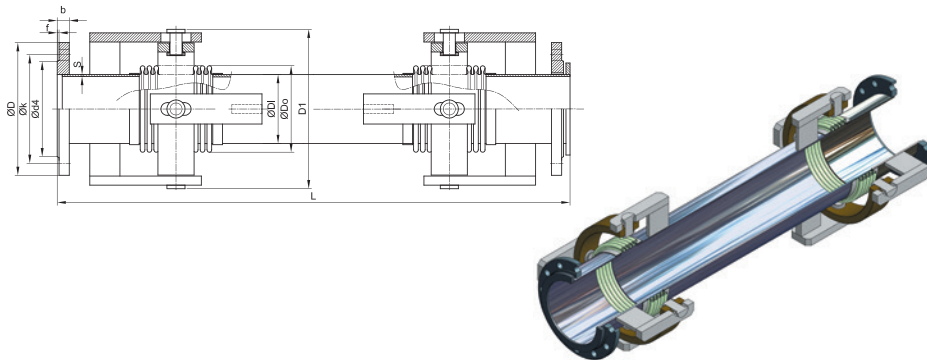

Alternative flange dimensions are also possible e.g. according to US standards (ANSI), JIS etc.

DN	Bellow			D1	s	SISKKF-50					SISKKF-100				
	ØDi	ØD0	Effective Bellow Area cm <sup>2</sup>			Movement			L	Code 175psi	Movement			L	Code 175psi
						± X	± Y	± Z			± X	± Y	± Z		
DN25	38	48,2	14,58	90	2,6	50	50	50	720	702.070.301.002	50	100	100	920	702.070.302.002
DN32	42,2	55	18,62	105	2,6	50	50	50	720	702.070.301.004	50	100	100	920	702.070.302.004
DN40	48,3	61	23,44	115	2,6	50	50	50	720	702.070.301.006	50	100	100	920	702.070.302.006
DN50	60,3	76	36,46	140	2,9	50	50	50	800	702.070.301.008	50	100	100	1000	702.070.302.008
DN65	76,1	95	57,45	160	2,9	50	50	50	800	702.070.301.010	50	100	100	1000	702.070.302.010
DN80	88,9	111	78,42	190	3,2	50	50	50	830	702.070.301.012	50	100	100	1030	702.070.302.012
DN100	114,3	140	137,09	250	3,6	50	50	50	850	702.070.301.014	50	100	100	1050	702.070.302.014
DN125	139,7	164	181,01	285	4	50	50	50	980	702.070.301.016	50	100	100	1180	702.070.302.016
DN150	168,3	200	266,20	350	4,5	50	50	50	980	702.070.301.018	50	100	100	1180	702.070.302.018
DN200	219,1	250	431,86	420	6,3	50	50	50	1140	702.070.301.020	50	100	100	1340	702.070.302.020
DN250	273	323	697,11	480	6,3	50	50	50	1140	702.070.301.022	50	100	100	1340	702.070.302.022
DN300	323,9	380	972,37	540	7,1	50	50	50	1200	702.070.301.024	50	100	100	1400	702.070.302.024

\* All dimensions given in the tables are in "mm"

\*\* Subject to technical alterations and deviations resulting from production process without giving any notification.

\*\*\* Contact Ayvaz sales team for the articles of 250psi version.

Reduction Factors for Pressure			
Temperature °C	Reduction Factor Kp	Temperature °C	Reduction Factor Kp
20	1,00	350	0,64
100	0,85	400	0,63
150	0,81	450	0,62
200	0,77	500	0,60
250	0,71	550	0,59
300	0,68	600	0,57

## Pressure reduction factor

The reduction factor is used to define the design pressure [PS] where temperatures exceed 20 °C. It compensates for the decay in material mechanical properties at elevated temperatures. The calculated pressure is lower than the nominal pressure of the standard item.

$$\text{Calculation: } PS \leq PN \times Kp$$

## DOUBLE GIMBAL EXPANSION JOINTS

### Double Gimbal Expansion Joints, Flanged

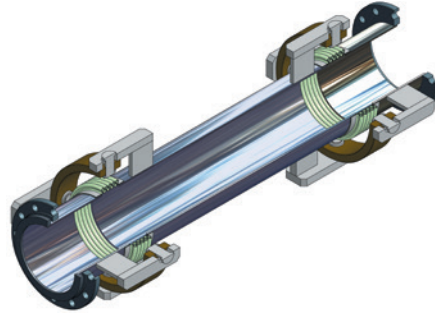
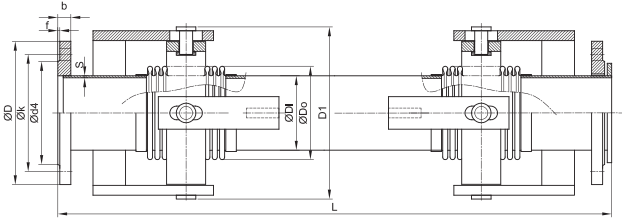

DN	Bellow			D1	s	SISKF-150					SISKF-200				
	ØDi	ØD0	Effective Bellow Area cm <sup>2</sup>			Expansion			L	Code 175psi	Expansion			L	Code 175psi
						± X	± Y	± Z	175psi 250psi		± X	± Y	± Z	175psi 250psi	
DN25	38	48,2	14,58	145	2,6	50	150	150	1120	702.070.303.002	50	200	200	1320	702.070.304.002
DN32	42,4	55	18,62	145	2,6	50	150	150	1120	702.070.303.004	50	200	200	1320	702.070.304.004
DN40	48,3	61	23,44	145	2,6	50	150	150	1120	702.070.303.006	50	200	200	1320	702.070.304.006
DN50	60,3	76	36,46	170	2,9	50	150	150	1200	702.070.303.008	50	200	200	1420	702.070.304.008
DN65	76,1	95	57,45	200	2,9	50	150	150	1250	702.070.303.010	50	200	200	1500	702.070.304.010
DN80	88,9	111	78,42	215	3,2	50	150	150	1270	702.070.303.012	50	200	200	1500	702.070.304.012
DN100	114,3	140	137,09	260	3,6	50	150	150	1300	702.070.303.014	50	200	200	1550	702.070.304.014
DN125	139,7	164	181,01	285	4	50	150	150	1480	702.070.303.016	50	200	200	1780	702.070.304.016
DN150	168,3	200	266,20	350	4,5	50	150	150	1480	702.070.303.018	50	200	200	1780	702.070.304.018
DN200	219,1	250	431,86	440	6,3	50	150	150	1700	702.070.303.020	50	200	200	2050	702.070.304.020
DN250	273	323	697,11	560	6,3	50	150	150	1700	702.070.303.022	50	200	200	2100	702.070.304.022
DN300	323,9	380	972,37	620	7,1	50	150	150	1750	702.070.303.024	50	200	200	2150	702.070.304.024

\* All dimensions given in the tables are in "mm"

\*\* Subject to technical alterations and deviations resulting from production process without giving any notification.

\*\*\* Contact Ayvaz sales team for the articles of 250psi version.

### Double Gimbal Expansion Joints, Welded End

#### Available Types (Standard Versions)

Double Gimbal Expansion Joints, Welded End				
Type	Lateral Movement	Axial Movement	Pressure Class	Available Sizes (DN)
SISKB-50	±50mm	±50mm	175 psi 250 psi	DN25-DN300 (FM approved) DN350-DN5000 (on request)
SISKB-100	±100mm	±50mm		
SISKB-150	±150mm	±50mm		
SISKB-200	±200mm	±50mm		

\* Special designed Double Gimbal type Expansion Joints with customized features are available on request.

# DOUBLE GIMBAL EXPANSION JOINTS

## Double Gimbal Expansion Joints, Welded End

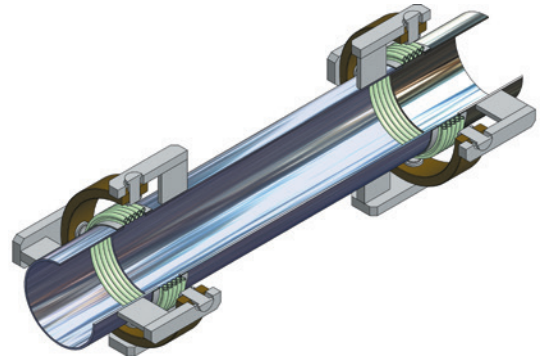
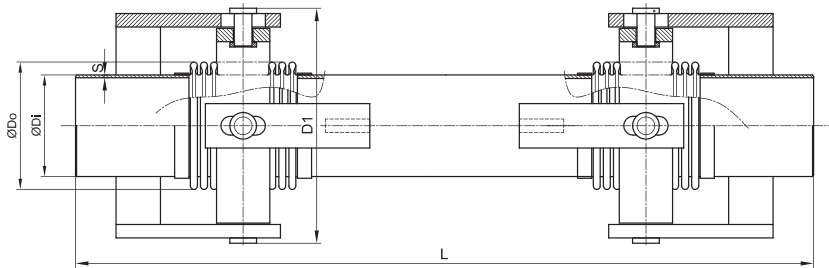

DN	Bellow			D1	s	SISKB-50					SISKB-100				
	ØDi	ØD0	Effective Bellow Area cm <sup>2</sup>			Expansion			L	Code 175psi	Expansion			L	Code 175psi
						± X	± Y	± Z			175psi 250psi	± X	± Y		
DN25	38	48,2	14,58	145	2,6	50	50	50	707	702.070.401.002	50	100	100	907	702.070.402.002
DN32	42,4	55	18,62	145	2,6	50	50	50	707	702.070.401.004	50	100	100	907	702.070.402.004
DN40	48,3	61	23,44	145	2,6	50	50	50	707	702.070.401.006	50	100	100	907	702.070.402.006
DN50	60,3	76	36,46	170	2,9	50	50	50	785	702.070.401.008	50	100	100	985	702.070.402.008
DN65	76,1	95	57,45	200	2,9	50	50	50	785	702.070.401.010	50	100	100	985	702.070.402.010
DN80	88,9	111	78,42	215	3,2	50	50	50	815	702.070.401.012	50	100	100	1015	702.070.402.012
DN100	114,3	140	137,09	260	3,6	50	50	50	835	702.070.401.014	50	100	100	1035	702.070.402.014
DN125	139,7	164	181,01	285	4	50	50	50	963	702.070.401.016	50	100	100	1163	702.070.402.016
DN150	168,3	200	266,20	350	4,5	50	50	50	963	702.070.401.018	50	100	100	1163	702.070.402.018
DN200	219,1	250	431,86	440	6,3	50	50	50	1120	702.070.401.020	50	100	100	1320	702.070.402.020
DN250	273	323	697,11	560	6,3	50	50	50	1120	702.070.401.022	50	100	100	1320	702.070.402.022
DN300	323,9	380	972,37	620	7,1	50	50	50	1177	702.070.401.024	50	100	100	1377	702.070.402.024

DN	Bellow			D1	s	SISKB-150					SISKB-200				
	ØDi	ØD0	Effective Bellow Area cm <sup>2</sup>			Expansion			L	Code	Expansion			L	Code
						± X	± Y	± Z			175psi 250psi	± X	± Y		
DN25	38	48,2	14,58	145	2,6	50	150	150	1107	702.070.403.002	50	200	200	1307	702.070.404.002
DN32	42,4	55	18,62	145	2,6	50	150	150	1107	702.070.403.004	50	200	200	1307	702.070.404.004
DN40	48,3	61	23,44	145	2,6	50	150	150	1107	702.070.403.006	50	200	200	1307	702.070.404.006
DN50	60,3	76	36,46	170	2,9	50	150	150	1185	702.070.403.008	50	200	200	1405	702.070.404.008
DN65	76,1	95	57,45	200	2,9	50	150	150	1235	702.070.403.010	50	200	200	1485	702.070.404.010
DN80	88,9	111	78,42	215	3,2	50	150	150	1255	702.070.403.012	50	200	200	1485	702.070.404.012
DN100	114,3	140	137,09	260	3,6	50	150	150	1285	702.070.403.014	50	200	200	1535	702.070.404.014
DN125	139,7	164	181,01	285	4	50	150	150	1463	702.070.403.016	50	200	200	1763	702.070.404.016
DN150	168,3	200	266,20	350	4,5	50	150	150	1463	702.070.403.018	50	200	200	1763	702.070.404.018
DN200	219,1	250	431,86	440	6,3	50	150	150	1680	702.070.403.020	50	200	200	2030	702.070.404.020
DN250	273	323	697,11	560	6,3	50	150	150	1680	702.070.403.022	50	200	200	2080	702.070.404.022
DN300	323,9	380	972,37	620	7,1	50	150	150	1727	702.070.403.024	50	200	200	2127	702.070.404.024

\* All dimensions given in the tables are in "mm"

\*\* Subject to technical alterations and deviations resulting from production process without giving any notification.

\*\*\* Contact Ayvaz sales team for the articles of 250psi version.



## DOUBLE GIMBAL EXPANSION JOINTS

### Double Gimbal Expansion Joints, Grooved End

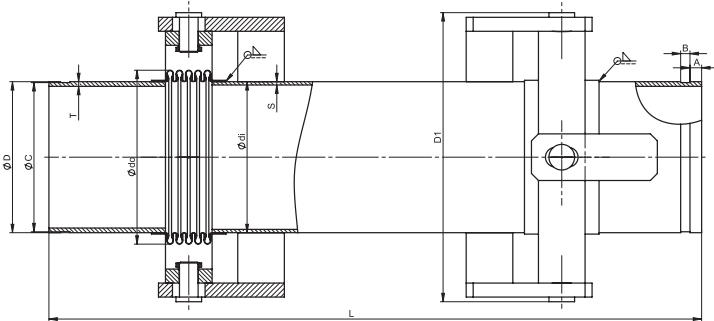

Double Gimbal Expansion Joints, Grooved End				
Type	Lateral Movement	Axial Movement	Pressure Class	Available Sizes (DN)
SISKY-50	±50mm	±50mm	175 psi 250 psi	DN25-DN300 (FM approved) DN350-DN5000 (on request)
SISKY-100	±100mm	±50mm		
SISKY-150	±150mm	±50mm		
SISKY-200	±200mm	±50mm		

\* Special designed Double Gimbal type Expansion Joints with customized features are available on request.

Groove Dimensions					
DN	A ±0,76	B ±0,76	T min	$\varnothing D$	$\varnothing C$
DN25	15,88	7,95	3,38	33,4	30,23
DN32	15,88	7,95	3,56	42,2	38,99
DN40	15,88	7,95	3,68	48,3	45,09
DN50	15,88	7,95	3,91	60,3	57,15
DN65	15,88	7,95	4,78	76,1	72,26
DN65	15,88	7,95	4,78	73	69,09
DN80	15,88	7,95	4,78	88,9	84,94
DN100	15,88	9,53	5,16	114,3	110,08
DN125	15,88	9,53	5,16	139,7	135,48
DN150	15,88	9,53	5,56	165,1	160,78
DN150	15,88	9,53	5,56	168,3	163,96
DN200	19,05	11,13	6,05	219,1	214,4
DN250	19,05	12,7	6,35	273	268,28
DN300	19,05	12,7	7,09	323,9	318,29

Alternative groove dimensions are also possible.

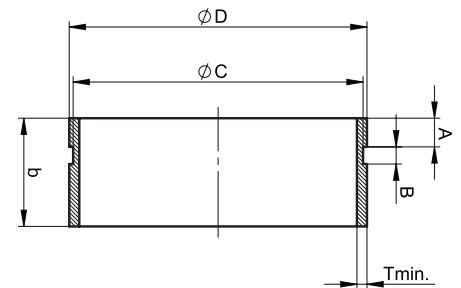

Reduction Factors for Pressure			
Temperature °C	Reduction Factor Kp	Temperature °C	Reduction Factor Kp
20	1,00	350	0,64
100	0,85	400	0,63
150	0,81	450	0,62
200	0,77	500	0,60
250	0,71	550	0,59
300	0,68	600	0,57

### Pressure reduction factor

The reduction factor is used to define the design pressure [PS] where temperatures exceed 20 °C. It compensates for the decay in material mechanical properties at elevated temperatures. The calculated pressure is lower than the nominal pressure of the standard item.

Calculation:  $PS \leq PN \times Kp$

## DOUBLE GIMBAL EXPANSION JOINTS

DN	Bellow			D1	s	SISKBY-50					SISKBY-100				
	ØDi	ØD0	Effective Bellow Area cm <sup>2</sup>			Expansion			L	Code 175psi	Expansion			L	Code 175psi
						± X	± Y	± Z	175psi 250psi		± X	± Y	± Z	175psi 250psi	
DN25	38	48,2	14,58	145	2,6	50	50	50	707	702.070.431.002	50	100	100	907	702.070.432.002
DN32	42,4	55	18,62	145	2,6	50	50	50	707	702.070.431.004	50	100	100	907	702.070.432.004
DN40	48,3	61	23,44	145	2,6	50	50	50	707	702.070.431.006	50	100	100	907	702.070.432.006
DN50	60,3	76	36,46	170	2,9	50	50	50	785	702.070.431.008	50	100	100	985	702.070.432.008
DN65	76,1	95	57,45	200	2,9	50	50	50	785	702.070.431.010	50	100	100	985	702.070.432.010
DN65	73	95	57,45	200	2,9	50	50	50	785	702.070.431.011	50	100	100	985	702.070.432.011
DN80	88,9	111	78,42	215	3,2	50	50	50	815	702.070.431.012	50	100	100	1015	702.070.432.012
DN100	114,3	140	137,09	260	3,6	50	50	50	835	702.070.431.014	50	100	100	1035	702.070.432.014
DN125	139,7	164	181,01	285	4	50	50	50	963	702.070.431.016	50	100	100	1163	702.070.432.016
DN150	165,1	200	266,20	350	4,5	50	50	50	963	702.070.431.018	50	100	100	1163	702.070.432.018
DN150	168,3	200	266,20	350	4,5	50	50	50	963	702.070.431.019	50	100	100	1163	702.070.432.019
DN200	219,1	250	431,86	440	6,3	50	50	50	1120	702.070.431.020	50	100	100	1320	702.070.432.020
DN250	273	323	697,11	560	6,3	50	50	50	1120	702.070.431.022	50	100	100	1320	702.070.432.022
DN300	323,9	380	972,37	620	7,1	50	50	50	1177	702.070.431.024	50	100	100	1377	702.070.432.024

DN	Bellow			D1	s	SISKBY-150					SISKBY-200				
	ØDi	ØD0	Effective Bellow Area cm <sup>2</sup>			Expansion			L	Code	Expansion			L	Code
						± X	± Y	± Z	175psi 250psi		± X	± Y	± Z	175psi 250psi	
DN25	38	48,2	14,58	145	2,6	50	150	150	1107	702.070.433.002	50	200	200	1307	702.070.434.002
DN32	42,4	55	18,62	145	2,6	50	150	150	1107	702.070.433.004	50	200	200	1307	702.070.434.004
DN40	48,3	61	23,44	145	2,6	50	150	150	1107	702.070.433.006	50	200	200	1307	702.070.434.006
DN50	60,3	76	36,46	170	2,9	50	150	150	1185	702.070.433.008	50	200	200	1405	702.070.434.008
DN65	76,1	95	57,45	200	2,9	50	150	150	1235	702.070.433.010	50	200	200	1485	702.070.434.010
DN65	73	95	57,45	200	2,9	50	150	150	1235	702.070.433.011	50	200	200	1485	702.070.434.011
DN80	88,9	111	78,42	215	3,2	50	150	150	1255	702.070.433.012	50	200	200	1485	702.070.434.012
DN100	114,3	140	137,09	260	3,6	50	150	150	1285	702.070.433.014	50	200	200	1535	702.070.434.014
DN125	139,7	164	181,01	285	4	50	150	150	1463	702.070.433.016	50	200	200	1763	702.070.434.016
DN150	165,1	200	266,20	350	4,5	50	150	150	1463	702.070.433.018	50	200	200	1763	702.070.434.018
DN150	168,3	200	266,20	350	4,5	50	150	150	1463	702.070.433.019	50	200	200	1763	702.070.434.019
DN200	219,1	250	431,86	440	6,3	50	150	150	1680	702.070.433.020	50	200	200	2030	702.070.434.020
DN250	273	323	697,11	560	6,3	50	150	150	1680	702.070.433.022	50	200	200	2080	702.070.434.022
DN300	323,9	380	972,37	620	7,1	50	150	150	1727	702.070.433.024	50	200	200	2127	702.070.434.024

\* All dimensions given in the tables are in "mm"

\*\* Subject to technical alterations and deviations resulting from production process without giving any notification.

\*\*\* Contact Ayvaz sales team for the articles of 250psi version.

## INSTALLATION OF GIMBAL TYPE SEISMIC DILATATION EXPANSION JOINTS

During a seismic motion, the pipelines are affected from the unforecasted movements just like the buildings. The most important points to be protected during such an event is the dilatation points.

### What is Dilatation Point?

Modern buildings are consisted of multiple independent sections the areas between two building is called dilatation point. The pipelines are goes through from one building to another should be protected with seismic motion absorption joints.

### Why are the dilatation points so important?

Because of the different aricteural and constructional features as well as the geological characteristics of the bases, the movements of buildings may differ.

So, pipeline costructors should use 3D motion absorber at these areas. Appropriate expansion joints must be installed to the pipelines underneath the dilatation points.

### Purpose of Dilatation Seismic Joints?

- This type of expansion are able to make movement in all three axis.
- The movement amount must be selected according to building displacement amount.
- Gimbals on the expansion joints are not used for making the joints restrained against the pressure thrust, only for limiting the axial movement capacity.

A gap which is equal to the movement amount of the expansion joint should be left between the joint and the construction elements like walls and ceiling. Both ends of the expansion joint should be fixed to each building with the distance of  $4D$ .

### Example

In case of a dilatation expansion joint with 100mm lateral deflection capacity to be installed at the dilatation point of 2 buildings.

The expansion joint should be placed in minimum 100mm distance from the ceiling, each ends should be fixed within 400mm.

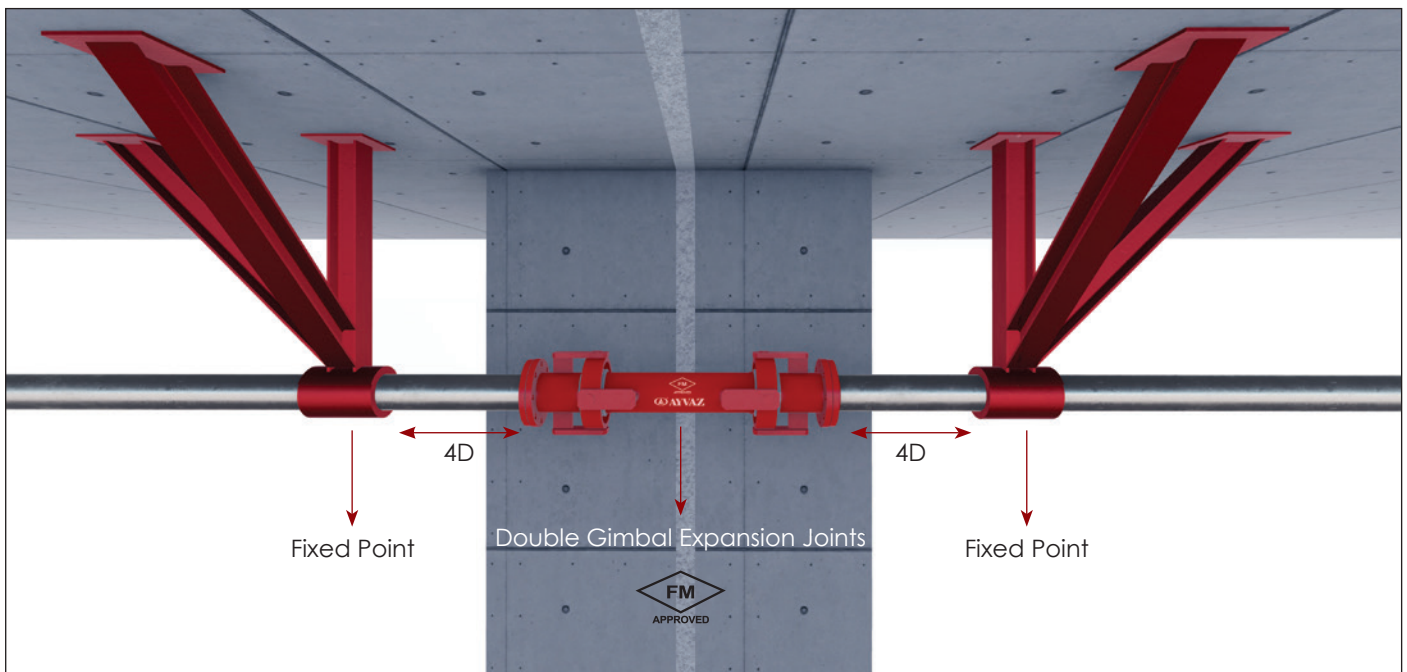

## BRAIDED LOOP JOINTS (U-TYPE)

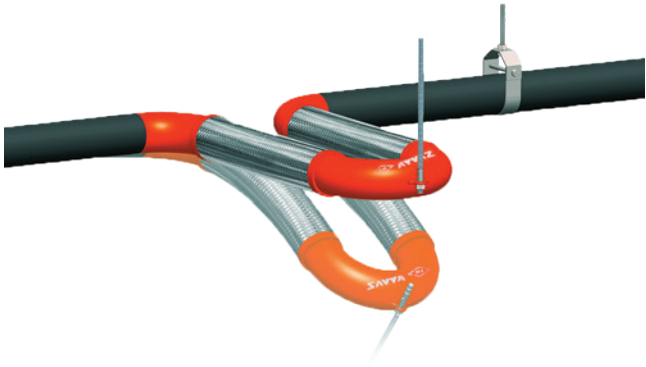

Scan this QR Code



The loop joint is designed to move in any direction making it a simple, all-in-one joint for a variety of applications. There's no limit to the seismic applications that loop joints can handle. It can even be designed with lined hose for high velocity, double-braid for high pressures, and all stainless steel construction for media compatibility.

### Loop Joint use for Seismic Protection

Piping used in applications and locations subject to seismic conditions have their own set of unexpected random movements and greater costs to overcome. The random motion common to earthquakes requires that seismic expansion joints be capable of movement in any direction. Of the 6 possible directions. Ayvaz Loopjoint's orientation can be changed relative to the piping, further minimizing the likelihood of compressive movement.

### Advantages of Braided Loop, Seismic Expansion Joints

- Loop joint offers significant cost and safety benefits not found in comparable seismic expansion joints
- FM approval for the safety features to be used at fire protection pipelines.
- Bellows design according to EJMA coding system.
- Construction according to EN14917 standard.
- Large lateral movements by single expansion joint

### Application Areas

- Fire Protection pipe lines
- Industrial process & applications

### DESIGN (EN 14917)

Bellow Material	Stainless Steel AISI 304 (opt.321,316L,316TI,309)
Braiding Material	Stainless Steel AISI 304
Connection Types	Floating Flanged, Welded Ended, Grooved & Threaded
Flange Material	PN 16, St.37.2 as standard, the material can be customised on request
Certificates	FM approval, Class 1920 Material certificate 3.1 according to EN 10204 and /or ASME

### Operation Conditions

Operating Temperature	-10°C/+550°C
Operating Pressure	175 psi & 250 psi Can be produced with different pressure rates

### Important

For detailed information, get in contact with Ayvaz's expert sales team. We strongly advise against the use of expansion joints and bellows for misalignment.



## BRAIDED LOOP JOINTS (U-TYPE)

### U-Flex, Braided Loop Joints, Flanged Connection



#### Available Types (Standard Versions)

U-type, Braided Loop-joint with Rotating Flanges		
Name	Movement in all planes	Design
U-Flex	±40mm (1,5") ±100mm (4") ±200mm (8") ±400mm (16") ±600mm (24")	175/250psi

Flange (DIN EN 1092/1) PN 16						
DN	ØD	Øk	Ød4	f	b	Ødxn
DN25	115	85	68	2	16	Ø 14x4
DN32	140	100	78	2	18	Ø 18x4
DN40	150	110	88	3	18	Ø 18x4
DN50	165	125	102	3	20	Ø 18x4
DN65	185	145	122	3	20	Ø 18x4
DN80	200	160	138	3	20	Ø 18x8
DN100	220	180	158	3	22	Ø 18x8
DN125	250	210	188	3	22	Ø 18x8
DN150	285	240	212	3	24	Ø 23x8
DN200	340	295	268	3	26	Ø 23x12
DN250	405	355	320	3	29	Ø 27x12
DN300	460	410	378	4	32	Ø 27x12

Alternative flange dimensions are also possible e.g. according to US standards (ANSI), JIS etc.

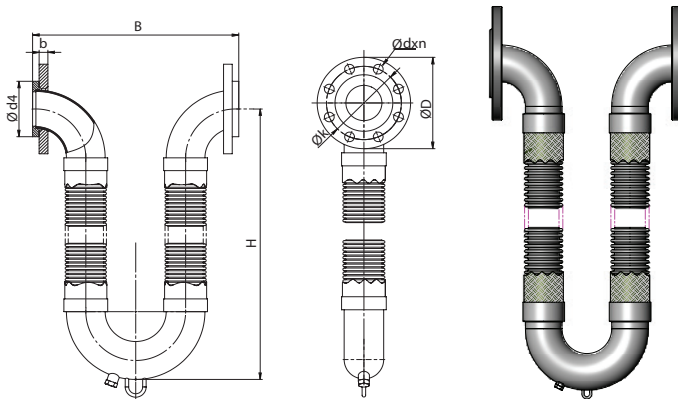

Size		Layer of Braiding		Ødi	s	R	1,5" movement (40mm)-175 PSI				4" movement (100mm)-175 PSI			
DN	inch	175 psi	250 psi				B	H	Lh	Code	B	H	Lh	Code
DN25	1"	1 ply	2 ply	33,7	2,6	38	222	380	287	702.080.303.030	324	510	417	702.080.303.035
DN32	1¼"	1 ply	2 ply	42,4	2,6	47,5	260	410	294	702.080.303.040	343	535	419	702.080.303.045
DN40	1½"	1 ply	2 ply	48,3	2,6	57	300	435	297	702.080.303.050	362	585	447	702.080.303.055
DN50	2"	1 ply	2 ply	60,3	2,9	76	375	485	303	702.080.303.060	426	635	453	702.080.303.065
DN65	2½"	1 ply	2 ply	76,1	2,9	95	450	535	307	702.080.303.070	450	715	487	702.080.303.075
DN80	3"	1 ply	2 ply	88,9	3,2	114	536	585	313	702.080.303.080	536	765	490	702.080.303.085
DN100	4"	1 ply	2 ply	114,3	3,6	152	680	715	354	702.080.303.090	680	890	529	702.080.303.095
DN125	5"	1 ply	2 ply	140	4	190	832	815	365	702.080.303.100	832	1020	570	702.080.303.105
DN150	6"	1 ply	2 ply	168,3	4,5	229	988	940	398	702.080.303.110	988	1170	628	702.080.303.115
DN200	8"	2 ply	3 ply	219	6	305	1292	1220	500	702.080.303.120	1292	1475	756	702.080.303.125
DN250	10"	2 ply	3 ply	273,0	6,3	381	1600	1400	502	702.080.303.130	1600	1702	804	702.080.303.135

- \* All dimensions given in the tables are in "mm"
- \*\* Subject to technical alterations and deviations resulting from production process without giving any notification.
- \*\*\* Contact Ayvaz sales team for the articles of 250psi version.
- \*\*\*\* Special designed, Braided Loop Joints with customized features are available on request.
- \*\*\*\*\* Contact Ayvaz sales team for the items with 8", 16" & 24" versions.

Reduction Factors for Pressure			
Temperature °C	Reduction Factor Kp	Temperature °C	Reduction Factor Kp
20	1,00	350	0,64
100	0,85	400	0,63
150	0,81	450	0,62
200	0,77	500	0,60
250	0,71	550	0,59
300	0,68	600	0,57

#### Pressure reduction factor

The reduction factor is used to define the design pressure [PS] where temperatures exceed 20 °C. It compensates for the decay in material mechanical properties at elevated temperatures. The calculated pressure is lower than the nominal pressure of the standard item.

$$\text{Calculation: } PS \leq PN \times Kp$$

# BRAIDED LOOP JOINTS (U-TYPE)

## U-Flex, Braided Loop Joints, Welded End Connection



### Available Types (Standard Versions)

U-type, Braided Loop-joint with Welded Ends		
Name	Movement in all planes	Design
U-Flex	±40mm (1,5") ±100mm (4") ±200mm (8") ±400mm (16") ±600mm (24")	175/250psi

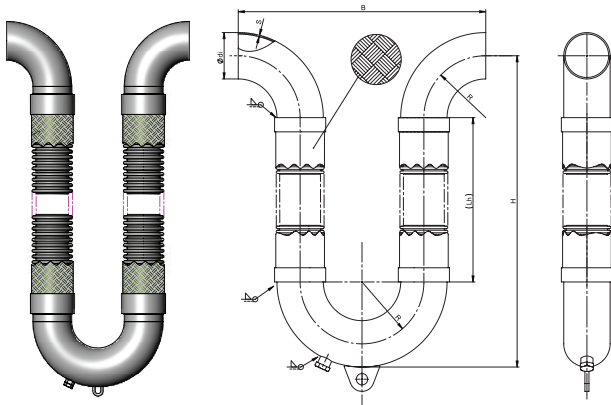

Size		Layer of Braiding		Ødi	s	R	1,5" movement (40mm)-175 PSI				4" movement (100mm)-175 PSI			
DN	inch	175 psi	250 psi				B	H	Lh	Code	B	H	Lh	Code
DN25	1"	1 ply	2 ply	33,7	2,6	38	152	380	287	702.080.301.030	254	510	417	702.080.301.035
DN32	1¼"	1 ply	2 ply	42,4	2,6	47,5	190	410	294	702.080.301.040	273	535	419	702.080.301.045
DN40	1½"	1 ply	2 ply	48,3	2,6	57	228	435	297	702.080.301.050	292	585	447	702.080.301.055
DN50	2"	1 ply	2 ply	60,3	2,9	76	304	485	303	702.080.301.060	356	635	453	702.080.301.065
DN65	2½"	1 ply	2 ply	76,1	2,9	95	380	535	307	702.080.301.070	380	715	487	702.080.301.075
DN80	3"	1 ply	2 ply	88,9	3,2	114	456	585	313	702.080.301.080	456	762	490	702.080.301.085
DN100	4"	1 ply	2 ply	114,3	3,6	152	608	715	354	702.080.301.090	608	890	529	702.080.301.095
DN125	5"	1 ply	2 ply	140	4	190	760	815	365	702.080.301.100	760	1020	570	702.080.301.105
DN150	6"	1 ply	2 ply	168,3	4,5	229	916	940	398	702.080.301.110	916	1170	628	702.080.301.115
DN200	8"	2 ply	3 ply	219	6	305	1220	1220	500	702.080.301.120	1220	1475	756	702.080.301.125
DN250	10"	2 ply	3 ply	273,0	6,3	381	1524	1400	502	702.080.301.130	1524	1702	804	702.080.301.135

\* All dimensions given in the tables are in "mm"  
 \*\* Subject to technical alterations and deviations resulting from production process without giving any notification.  
 \*\*\* Contact Ayvaz sales team for the articles of 250psi version.  
 \*\*\*\* Special designed, Braided Loop Joints with customized features are available on request.  
 \*\*\*\*\* Contact Ayvaz sales team for the items with 8", 16" & 24" versions.

Reduction Factors for Pressure			
Temperature °C	Reduction Factor Kp	Temperature °C	Reduction Factor Kp
20	1,00	350	0,64
100	0,85	400	0,63
150	0,81	450	0,62
200	0,77	500	0,60
250	0,71	550	0,59
300	0,68	600	0,57

### Pressure reduction factor

The reduction factor is used to define the design pressure [PS] where temperatures exceed 20 °C. It compensates for the decay in material mechanical properties at elevated temperatures. The calculated pressure is lower than the nominal pressure of the standard item.

Calculation:  $PS \leq PN \times Kp$

## BRAIDED LOOP JOINTS (U-TYPE)

### U-Flex, Braided Loop Joints, Grooved End

#### Available Types (Standard Versions)

U-type, Braided Loop-joint with Grooved End		
Name	Movement in all planes	Design
U-Flex	±40mm (1,5") ±100mm (4") ±200mm (8") ±400mm (16") ±600mm (24")	175/250psi

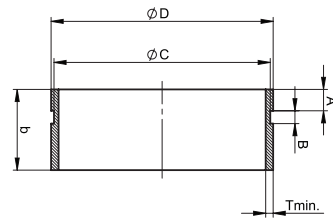
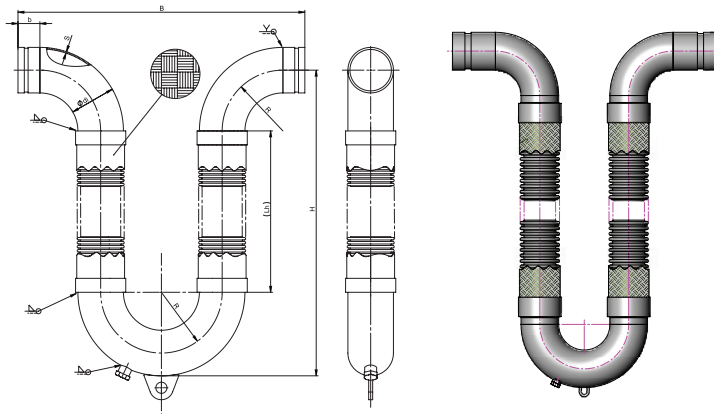

Groove Dimensions						
DN	A ±0,76	B ±0,76	T min	øD	øC	b
DN25	15,88	7,95	3,38	33,4	30,23	55
DN32	15,88	7,95	3,56	42,2	38,99	55
DN40	15,88	7,95	3,68	48,3	45,09	55
DN50	15,88	7,95	3,91	60,3	57,15	55
DN65	15,88	7,95	4,78	76,1	72,26	55
DN65	15,88	7,95	4,78	73	69,09	55
DN80	15,88	7,95	4,78	88,9	84,94	55
DN100	15,88	9,53	5,16	114,3	110,08	55
DN125	15,88	9,53	5,16	139,7	135,48	60
DN150	15,88	9,53	5,56	165,1	160,78	60
DN150	15,88	9,53	5,56	168,3	163,96	60
DN200	19,05	11,13	6,05	219,1	214,4	65
DN250	19,05	12,7	6,35	273	268,28	65

Alternative groove dimensions are also possible.

Size		Layer of Braiding		Ødi	R	s	1,5" movement (40mm)-175 PSI				4" movement (100mm)-175 PSI			
DN	inch	175 psi	250 psi				B	H	Lh	Code	B	H	Lh	Code
DN25	1"	1 ply	2 ply	33,7	38	2,6	262	380	287	702.080.307.000	364	510	417	702.080.307.005
DN32	1¼"	1 ply	2 ply	42,4	47,5	2,6	300	410	294	702.080.307.010	383	535	419	702.080.307.015
DN40	1½"	1 ply	2 ply	48,3	57	2,6	338	435	297	702.080.307.020	402	585	447	702.080.307.025
DN50	2"	1 ply	2 ply	60,3	76	2,9	414	485	303	702.080.307.030	466	635	453	702.080.307.035
DN65	2½"	1 ply	2 ply	76,1	95	2,9	491	535	307	702.080.307.040	490	715	487	702.080.307.045
DN65	2½"	1 ply	2 ply	73	95	2,9	491	535	307	702.080.307.345	490	715	487	702.080.307.350
DN80	3"	1 ply	2 ply	88,9	114	3,2	568	585	313	702.080.307.060	566	762	490	702.080.307.065
DN100	4"	1 ply	2 ply	114,3	152	3,6	720	715	354	702.080.307.070	718	890	529	702.080.307.075
DN125	5"	1 ply	2 ply	140	190	4	882	815	365	702.080.307.080	880	1020	570	702.080.307.085
DN150	6"	1 ply	2 ply	165,1	229	4,5	1036	940	398	702.080.307.090	1036	1170	628	702.080.307.095
DN150	6"	1 ply	2 ply	168,3	229	4,5	1036	940	398	702.080.307.390	1036	1170	628	702.080.307.395
DN200	8"	2 ply	3 ply	219	305	6	1350	1220	500	702.080.307.100	1350	1475	756	702.080.307.105
DN250	10"	2 ply	3 ply	273,0	381	6,3	1654	1400	502	702.080.307.110	1654	1702	804	702.080.307.115

\* All dimensions given in the tables are in "mm"

\*\* Subject to technical alterations and deviations resulting from production process without giving any notification.

\*\*\* Contact Ayvaz sales team for the articles of 250psi version.

\*\*\*\* Special designed, Braided Loop Joints with customized features are available on request.

\*\*\*\*\* Contact Ayvaz sales team for the items with 8", 16" & 24" versions.

Reduction Factors for Pressure			
Temperature °C	Reduction Factor Kp	Temperature °C	Reduction Factor Kp
20	1,00	350	0,64
100	0,85	400	0,63
150	0,81	450	0,62
200	0,77	500	0,60
250	0,71	550	0,59
300	0,68	600	0,57

### Pressure reduction factor

The reduction factor is used to define the design pressure [PS] where temperatures exceed 20 °C. It compensates for the decay in material mechanical properties at elevated temperatures. The calculated pressure is lower than the nominal pressure of the standard item.

Calculation:  $PS \leq PN \times Kp$

# BRAIDED LOOP JOINTS (U-TYPE)

## U-Flex, Braided Loop Joints, Threaded End



### Available Types (Standard Versions)

U-type, Braided Loop-joint with EN 10226-1(R) Thread		
Name	Movement in all planes	Design
U-Flex	±40mm (1,5") ±100mm (4") ±200mm (8") ±400mm (16") ±600mm (24")	175/250psi

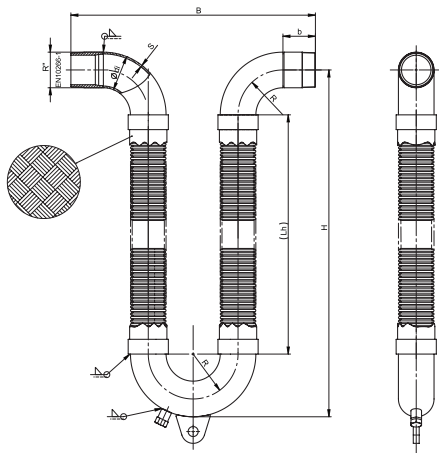

Size		Layer of Braiding		Ødi	s	R	b	1,5" movement (40mm)-175 PSI				4" movement (100mm)-175 PSI			
DN	inch	175 psi	250 psi					B	H	Lh	Code	B	H	Lh	Code
DN25	1"	1 ply	2 ply	33,7	2,6	38	55	560	330	318	702.090.305.030	747	492	455	702.090.305.035
DN32	1 1/4"	1 ply	2 ply	42,4	2,6	47,5	55	577	330	302	702.090.305.040	790	515	465	702.090.305.045
DN40	1 1/2"	1 ply	2 ply	48,3	2,6	57	55	594	330	287	702.090.305.050	847	549	490	702.090.305.055
DN50	2"	1 ply	2 ply	60,3	2,9	76	55	678	370	305	702.090.305.060	925	582	500	702.090.305.065
DN65	2 1/2"	1 ply	2 ply	76,1	2,9	95	55	789	436	350	702.090.305.070	1060	670	550	702.090.305.075
DN80	3"	1 ply	2 ply	88,9	3,2	114	55	878	480	373	702.090.305.080	1175	739	600	702.090.305.085
DN100	4"	1 ply	2 ply	114,3	3,6	152	55	1043	560	405	702.090.305.090	1358	833	650	702.090.305.095
DN125	5"	1 ply	2 ply	140	4	190	60	1230	650	450	702.090.305.100	1600	970	750	702.090.305.105
DN150	6"	1 ply	2 ply	168,3	4,5	229	60	1417	750	505	702.090.305.110	1807	1088	825	702.090.305.115

\* All dimensions given in the tables are in "mm"

\*\* Subject to technical alterations and deviations resulting from production process without giving any notification.

\*\*\* Contact Ayvaz sales team for the articles of 250psi version.

\*\*\*\* Special designed, Braided Loop Joints with customized features are available on request.

\*\*\*\*\* Contact Ayvaz sales team for the items with 8", 16" & 24" versions.

Reduction Factors for Pressure			
Temperature °C	Reduction Factor Kp	Temperature °C	Reduction Factor Kp
20	1,00	350	0,64
100	0,85	400	0,63
150	0,81	450	0,62
200	0,77	500	0,60
250	0,71	550	0,59
300	0,68	600	0,57

### Pressure reduction factor

The reduction factor is used to define the design pressure [PS] where temperatures exceed 20 °C. It compensates for the decay in material mechanical properties at elevated temperatures. The calculated pressure is lower than the nominal pressure of the standard item.

$$\text{Calculation: } PS \leq PN \times Kp$$

## BRAIDED LOOP JOINTS (V-TYPE)

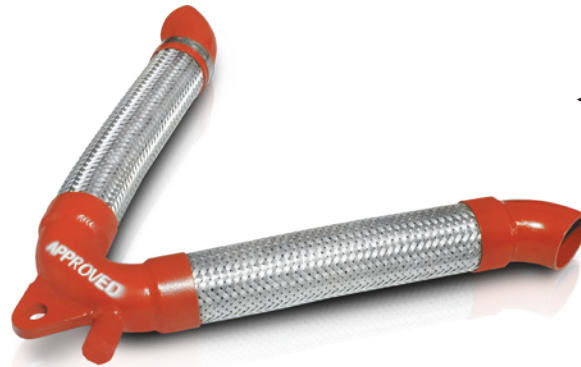

Scan this QR Code



The loop joint is designed to move in any direction making it a simple, all-in-one joint for a variety of applications.

There's no limit to the seismic applications that loop joints can handle. It can even be designed with lined hose for high velocity, double-braid for high pressures, and all stainless steel construction for media compatibility.

### Loop Joint use for Seismic Protection

Piping used in applications and locations subject to seismic conditions have their own set of unexpected random movements and greater costs to overcome. The random motion common to earthquakes requires that seismic expansion joints be capable of movement in any direction. Of the 6 possible directions, Ayvaz Loopjoint's orientation can be changed relative to the piping, further minimizing the likelihood of compressive movement.

### Advantages of Braided Loop, Seismic Expansion Joints

- Loop joint offers significant cost and safety benefits not found in comparable seismic expansion joints
- FM approval for the safety features to be used at fire protection pipelines.
- Bellows design according to EJMA coding system.
- Construction according to EN14917 standard.
- Large lateral movements by single expansion joint

### Application Areas

- Fire Protection
- Industrial process & applications

### DESIGN (EN 14917)

Bellow Material	Stainless Steel AISI 304 (opt.321,316L,316TI,309)
Braiding Material	Stainless Steel AISI 304
Connection Types	Floating Flanged, Welded Ended, Grooved & Threaded
Flange Material	PN 16, St.37.2 as standard, the material can be customised on request
Certificates	Material certificate 3.1 according to EN 10204 and /or ASME FM certificate

### Operation Conditions

Operating Temperature	-10°C/+550°C
Operating Pressure	Standard pressure rating is 175 & 250psi Can be produced with different pressure rates PN 2,5-63 PN corresponds to the allowable operating pressure at room temperature

### Important

For detailed information, get in contact with Ayvaz's expert sales team. We strongly advise against the use of expansion joints and bellows for misalignment.



# BRAIDED LOOP JOINTS (V-TYPE)

## V-Flex, Braided Loop Joints, Flanged Connection



### Available Types (Standard Versions)

V-type, Braided Loop-joint with Rotating Flanges		
Name	Movement in all planes	Design
V-Flex	±40mm (1,5") ±100mm (4") ±200mm (8") ±400mm (16") ±600mm (24")	175/250psi

Flange (DIN EN 1092/1) PN 16						
DN	ØD	Øk	Ød4	f	b	Ødxn
DN25	115	85	68	2	16	Ø 14x4
DN32	140	100	78	2	18	Ø 18x4
DN40	150	110	88	3	18	Ø 18x4
DN50	165	125	102	3	20	Ø 18x4
DN65	185	145	122	3	20	Ø 18x4
DN80	200	160	138	3	20	Ø 18x8
DN100	220	180	158	3	22	Ø 18x8
DN125	250	210	188	3	22	Ø 18x8
DN150	285	240	212	3	24	Ø 23x8
DN200	340	295	268	3	26	Ø 23x12
DN250	405	355	320	3	29	Ø 27x12
DN300	460	410	378	4	32	Ø 27x12

Alternative flange dimensions are also possible e.g. according to US standards (ANSI), JIS etc.

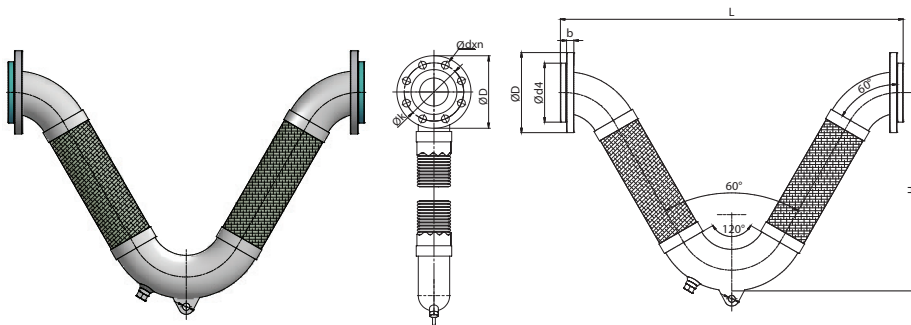

Size		Layer of Braiding		Ødi	s	R	1,5" movement (40mm)-175 PSI				4" movement (100mm)-175 PSI			
DN	inch	175 psi	250 psi				B	H	Lh	Code	B	H	Lh	Code
DN25	1"	1 ply	2 ply	33,7	2,6	38	520	330	318	702.090.303.030	707	492	455	702.090.303.035
DN32	1¼"	1 ply	2 ply	42,4	2,6	47,5	537	330	302	702.090.303.040	750	515	465	702.090.303.045
DN40	1½"	1 ply	2 ply	48,3	2,6	57	554	330	287	702.090.303.050	807	549	490	702.090.303.055
DN50	2"	1 ply	2 ply	60,3	2,9	76	638	370	305	702.090.303.060	885	584	500	702.090.303.065
DN65	2½"	1 ply	2 ply	76,1	2,9	95	749	436	350	702.090.303.070	1020	670	550	702.090.303.075
DN80	3"	1 ply	2 ply	88,9	3,2	114	838	480	373	702.090.303.080	1135	739	600	702.090.303.085
DN100	4"	1 ply	2 ply	114,3	3,6	152	1005	560	405	702.090.303.090	1320	834	650	702.090.303.095
DN125	5"	1 ply	2 ply	140	4	190	1182	650	450	702.090.303.100	1552	972	750	702.090.303.105
DN150	6"	1 ply	2 ply	168,3	4,5	229	1369	750	505	702.090.303.110	1759	1088	825	702.090.303.115
DN200	8"	2 ply	3 ply	219	6	305	1689	900	560	702.090.303.120	2102	1255	900	702.090.303.125
DN250	10"	2 ply	3 ply	273,0	6,3	381	2045	1080	650	702.090.303.130	2515	1487	1050	702.090.303.135

\* All dimensions given in the tables are in "mm"  
 \*\* Subject to technical alterations and deviations resulting from production process without giving any notification.  
 \*\*\* Contact Ayvaz sales team for the articles of 250psi version.  
 \*\*\*\* Special designed, Braided Loop Joints with customized features are available on request.  
 \*\*\*\*\* Contact Ayvaz sales team for the items with 8", 16" & 24" versions.

Reduction Factors for Pressure			
Temperature °C	Reduction Factor Kp	Temperature °C	Reduction Factor Kp
20	1,00	350	0,64
100	0,85	400	0,63
150	0,81	450	0,62
200	0,77	500	0,60
250	0,71	550	0,59
300	0,68	600	0,57

### Pressure reduction factor

The reduction factor is used to define the design pressure [PS] where temperatures exceed 20 °C. It compensates for the decay in material mechanical properties at elevated temperatures. The calculated pressure is lower than the nominal pressure of the standard item.

Calculation:  $PS \leq PN \times Kp$

# BRAIDED LOOP JOINTS (V-TYPE)

## V-Flex, Braided Loop Joints, Welded End Connection



### Available Types (Standard Versions)

V-type, Braided Loop-joint with Welded Ends		
Name	Movement in all planes	Design
V-Flex	±40mm (1,5") ±100mm (4") ±200mm (8") ±400mm (16") ±600mm (24")	175/250psi

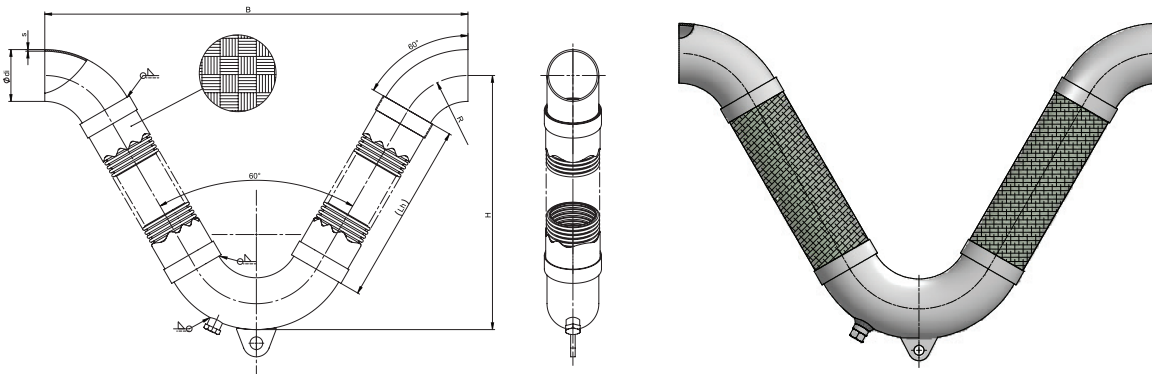

Size		Layer of Braiding		Ødi	s	R	1,5" movement (40mm)-175 PSI				4" movement (100mm)-175 PSI			
DN	inch	175 psi	250 psi				B	H	Lh	Code	B	H	Lh	Code
DN25	1"	1 ply	2 ply	33,7	2,6	38	450	330	318	702.090.301.030	637	492	455	702.090.301.035
DN32	1¼"	1 ply	2 ply	42,4	2,6	47,5	467	330	302	702.090.301.040	680	515	465	702.090.301.045
DN40	1½"	1 ply	2 ply	48,3	2,6	57	484	330	287	702.090.301.050	737	549	490	702.090.301.055
DN50	2"	1 ply	2 ply	60,3	2,9	76	568	370	305	702.090.301.060	815	584	500	702.090.301.065
DN65	2½"	1 ply	2 ply	76,1	2,9	95	679	436	350	702.090.301.070	950	670	550	702.090.301.075
DN80	3"	1 ply	2 ply	88,9	3,2	114	768	480	373	702.090.301.080	1065	739	600	702.090.301.085
DN100	4"	1 ply	2 ply	114,3	3,6	152	933	560	405	702.090.301.090	1248	834	650	702.090.301.095
DN125	5"	1 ply	2 ply	140	4	190	1110	650	450	702.090.301.100	1480	872	750	702.090.301.105
DN150	6"	1 ply	2 ply	168,3	4,5	229	1297	750	505	702.090.301.110	1687	1088	825	702.090.301.115
DN200	8"	2 ply	3 ply	219	6	305	1617	900	560	702.090.301.120	2027	1255	900	702.090.301.125
DN250	10"	2 ply	3 ply	273,0	6,3	381	1970	1080	650	702.090.301.130	2440	1488	1050	702.090.301.135

\* All dimensions given in the tables are in "mm"  
 \*\* Subject to technical alterations and deviations resulting from production process without giving any notification.  
 \*\*\* Contact Ayvaz sales team for the articles of 250psi version.  
 \*\*\*\* Special designed, Braided Loop Joints with customized features are available on request.  
 \*\*\*\*\* Contact Ayvaz sales team for the items with 8", 16" & 24" versions.

Reduction Factors for Pressure			
Temperature °C	Reduction Factor Kp	Temperature °C	Reduction Factor Kp
20	1,00	350	0,64
100	0,85	400	0,63
150	0,81	450	0,62
200	0,77	500	0,60
250	0,71	550	0,59
300	0,68	600	0,57

### Pressure reduction factor

The reduction factor is used to define the design pressure [PS] where temperatures exceed 20 °C. It compensates for the decay in material mechanical properties at elevated temperatures. The calculated pressure is lower than the nominal pressure of the standard item.

Calculation:  $PS \leq PN \times Kp$

# BRAIDED LOOP JOINTS (V-TYPE)

## V-Flex, Braided Loop Joints, Grooved End

### Available Types (Standard Versions)

V-type, Braided Loop-joint with Grooved End		
Name	Movement in all planes	Design
V-Flex	±40mm (1,5") ±100mm (4") ±200mm (8") ±400mm (16") ±600mm (24")	175/250psi

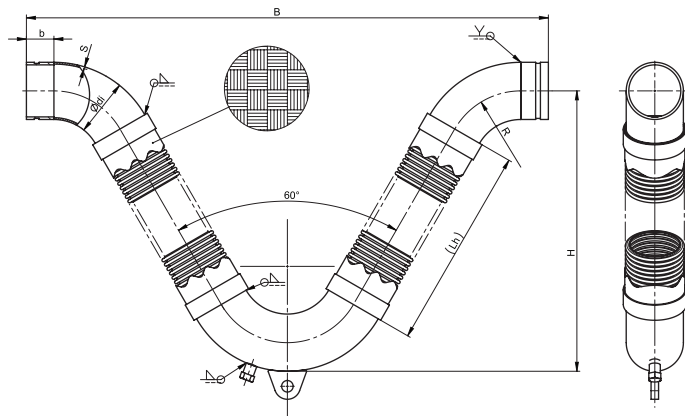
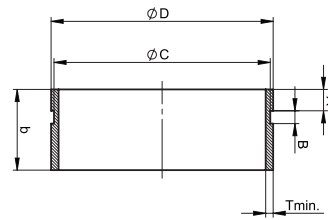

Groove Dimensions						
DN	A ±0,76	B ±0,76	T min	øD	øC	b
DN25	15,88	7,95	3,38	33,4	30,23	55
DN32	15,88	7,95	3,56	42,2	38,99	55
DN40	15,88	7,95	3,68	48,3	45,09	55
DN50	15,88	7,95	3,91	60,3	57,15	55
DN65	15,88	7,95	4,78	76,1	72,26	55
DN80	15,88	7,95	4,78	88,9	84,94	55
DN100	15,88	9,53	5,16	114,3	110,08	55
DN125	15,88	9,53	5,16	139,7	135,48	60
DN150	15,88	9,53	5,56	165,1	160,78	60
DN200	19,05	11,13	6,05	219,1	214,4	65
DN250	19,05	12,7	6,35	273	268,28	65

Alternative groove dimensions are also possible.

Size		Layer of Braiding		Ødi	s	R	1,5" movement (40mm)-175 PSI				4" movement (100mm)-175 PSI			
DN	inch	175 psi	250 psi				B	H	Lh	Code	B	H	Lh	Code
DN25	1"	1 ply	2 ply	33,7	2,6	38	560	330	318	702.090.304.030	747	492	455	702.090.304.035
DN32	1¼"	1 ply	2 ply	42,4	2,6	47,5	577	330	302	702.090.304.040	790	515	465	702.090.304.045
DN40	1½"	1 ply	2 ply	48,3	2,6	57	594	330	287	702.090.304.050	847	549	490	702.090.304.055
DN50	2"	1 ply	2 ply	60,3	2,9	76	678	370	305	702.090.304.060	925	582	500	702.090.304.065
DN65	2½"	1 ply	2 ply	76,1	2,9	95	789	436	350	702.090.304.070	1060	670	550	702.090.304.075
DN65	2½"	1 ply	2 ply	73	2,9	95	789	436	350	702.090.304.345	1060	670	550	702.090.304.350
DN80	3"	1 ply	2 ply	88,9	3,2	114	878	480	373	702.090.304.080	1175	739	600	702.090.304.085
DN100	4"	1 ply	2 ply	114,3	3,6	152	1043	560	405	702.090.304.090	1358	833	650	702.090.304.095
DN125	5"	1 ply	2 ply	140	4	190	1230	650	450	702.090.304.100	1600	970	750	702.090.304.105
DN150	6"	1 ply	2 ply	165,1	4,5	229	1417	750	505	702.090.304.110	1807	1088	825	702.090.304.115
DN150	6"	1 ply	2 ply	168,3	4,5	229	1417	750	505	702.090.304.390	1807	1088	825	702.090.304.395
DN200	8"	2 ply	3 ply	219	6	305	1747	900	560	702.090.304.120	2157	1255	900	702.090.304.125
DN250	10"	2 ply	3 ply	273,0	6,3	381	2100	1080	650	702.090.304.130	2570	1487	1050	702.090.304.135

\* All dimensions given in the tables are in "mm"

\*\* Subject to technical alterations and deviations resulting from production process without giving any notification.

\*\*\* Contact Ayvaz sales team for the articles of 250psi version.

\*\*\*\* Special designed, Braided Loop Joints with customized features are available on request.

\*\*\*\*\* Contact Ayvaz sales team for the items with 8", 16" & 24" versions.

Reduction Factors for Pressure			
Temperature °C	Reduction Factor Kp	Temperature °C	Reduction Factor Kp
20	1,00	350	0,64
100	0,85	400	0,63
150	0,81	450	0,62
200	0,77	500	0,60
250	0,71	550	0,59
300	0,68	600	0,57

### Pressure reduction factor

The reduction factor is used to define the design pressure [PS] where temperatures exceed 20 °C. It compensates for the decay in material mechanical properties at elevated temperatures. The calculated pressure is lower than the nominal pressure of the standard item.

Calculation:  $PS \leq PN \times Kp$

# BRAIDED LOOP JOINTS (V-TYPE)

## V-Flex, Braided Loop Joints, Threaded End



### Available Types (Standard Versions)

V-type, Braided Loop-joint with EN 10226-1 (R) Thread		
Name	Movement in all planes	Design
V-Flex	±40mm (1,5") ±100mm (4") ±200mm (8") ±400mm (16") ±600mm (24")	175/250psi

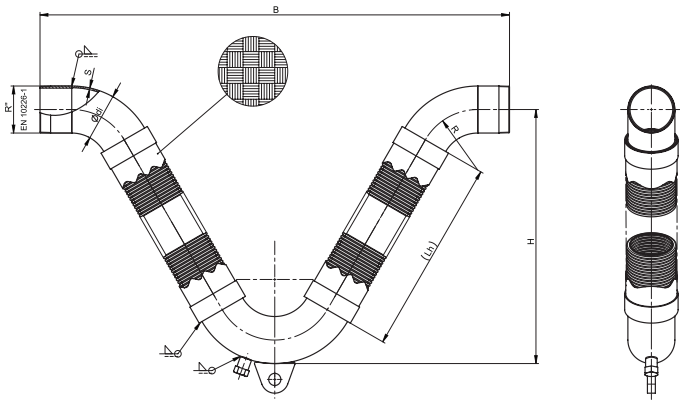

Size		Layer of Braiding		Ødi	s	R	b	1,5" movement (40mm)-175 PSI				4" movement (100mm)-175 PSI			
DN	inch	175 psi	250 psi					B	H	Lh	Code	B	H	Lh	Code
DN25	1"	1 ply	2 ply	33,7	2,6	38	55	560	330	318	702.090.305.030	747	492	455	702.090.305.035
DN32	1¼"	1 ply	2 ply	42,4	2,6	47,5	55	577	330	302	702.090.305.040	790	515	465	702.090.305.045
DN40	1½"	1 ply	2 ply	48,3	2,6	57	55	594	330	287	702.090.305.050	847	549	490	702.090.305.055
DN50	2"	1 ply	2 ply	60,3	2,9	76	55	678	370	305	702.090.305.060	925	582	500	702.090.305.065
DN65	2½"	1 ply	2 ply	76,1	2,9	95	55	789	436	350	702.090.305.070	1060	670	550	702.090.305.075
DN80	3"	1 ply	2 ply	88,9	3,2	114	55	878	480	373	702.090.305.080	1175	739	600	702.090.305.085
DN100	4"	1 ply	2 ply	114,3	3,6	152	55	1043	560	405	702.090.305.090	1358	833	650	702.090.305.095
DN125	5"	1 ply	2 ply	140	4	190	60	1230	650	450	702.090.305.100	1600	970	750	702.090.305.105
DN150	6"	1 ply	2 ply	168,3	4,5	229	60	1417	750	505	702.090.305.110	1807	1088	825	702.090.305.115

\* All dimensions given in the tables are in "mm"  
 \*\* Subject to technical alterations and deviations resulting from production process without giving any notification.  
 \*\*\* Contact Ayvaz sales team for the articles of 250psi version.  
 \*\*\*\* Special designed, Braided Loop Joints with customized features are available on request.  
 \*\*\*\*\* Contact Ayvaz sales team for the items with 8", 16" & 24" versions.

Reduction Factors for Pressure			
Temperature °C	Reduction Factor Kp	Temperature °C	Reduction Factor Kp
20	1,00	350	0,64
100	0,85	400	0,63
150	0,81	450	0,62
200	0,77	500	0,60
250	0,71	550	0,59
300	0,68	600	0,57

### Pressure reduction factor

The reduction factor is used to define the design pressure [PS] where temperatures exceed 20 °C. It compensates for the decay in material mechanical properties at elevated temperatures. The calculated pressure is lower than the nominal pressure of the standard item.

Calculation:  $PS \leq PN \times Kp$

## INSTALLATION INSTRUCTIONS

### Motion Of Braided Loop Joints

The loop joint is designed to move in any direction making it a simple, all-in-one joint for a variety of applications. There's no limit to the seismic applications that loop joints can handle. It can even be designed with lined hose for high velocity, double-braid for high pressures, and all stainless steel construction for media compatibility.

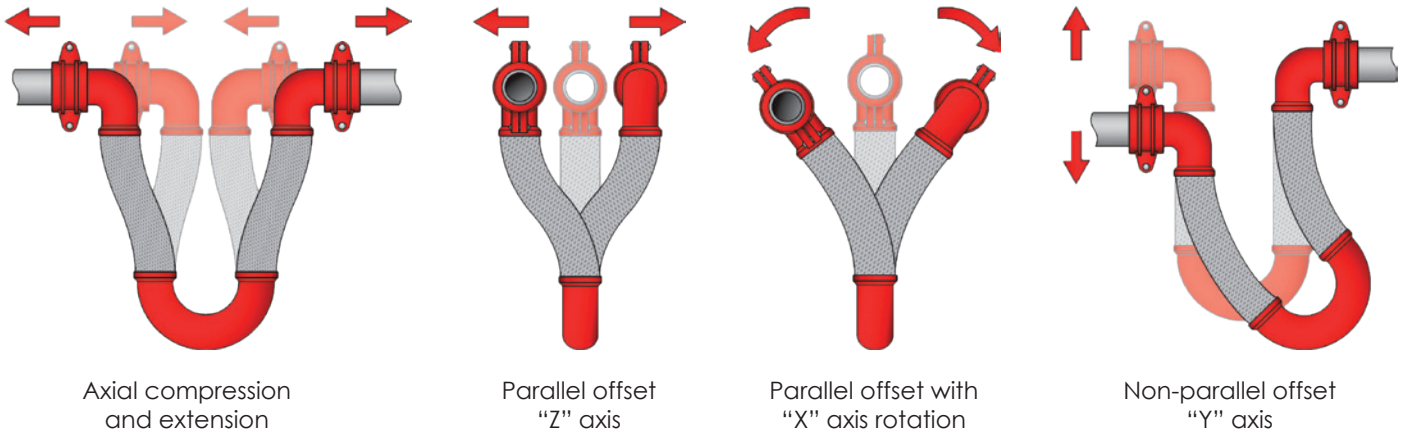

### Connection Types of Loop Joints



#### Horizontal Connection (Hanging Down)

Loop should hang straight down and be free to flex. Guides are required to direct movement axially.

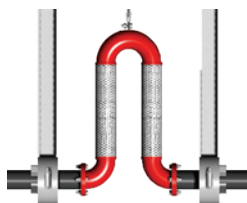

#### Horizontal Connection (Straight Up)

Support must be provided to prevent the loop from leaning. Pipe hanger rod should be loose enough to allow the 180° return to move up or down 1/4" as the loop flexes. Guides are required to direct movement of pipe axially.



#### Horizontal Connection

This installation is recommended for steam. Support must be provided to prevent the loop from drooping or torquing pipe. Support must allow the 180° return, to move horizontally back and forth 1/4", as the loop flexes. Guides are required to direct movement of pipe axially.

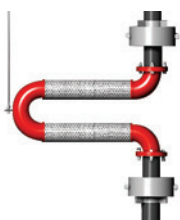

#### Vertical Connection

Loop must be supported to allow the 180° return to move horizontally back and forth 1/4" as the loop flexes. Guides are required to direct movement of pipe axially.



## INSTALLATION INSTRUCTIONS

### Connection Types of Loop Joints



#### Nested Connection

For tight pipe runs, any size or number of loops can be designed to nest inside of one another. To order, specify sequence of pipe diameters and corresponding distances between pipe centerlines.

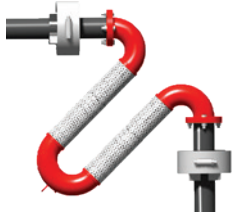

#### Inside Corner Connection

Single loop joint simultaneously absorbs the thermal expansion of two pipe runs. Space-saving inside corner joint connection eliminates the need for an anchor at the corner. Guides are required to direct movement of pipe axially. Support must be provided to prevent loop joint from drooping or torquing pipe and must allow for sufficient movement.



#### Over-Under Connection

The loop joints expansion loop can be manufactured in a variety of configurations.

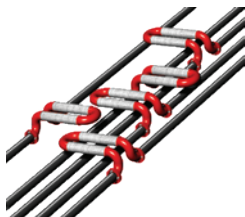

#### Over-Over Connection

The loop joints expansion loop can be manufactured in a variety of configurations.

### Ayvaz Loop Joints Installation Instructions

1. Ayvaz loop joints can be connected to pipeline with welding ends, flanges or grooved connection mounts through rigid or flexible couplings.
2. Loop joints can be installed in any position with maximum efficiency.
3. For the Loop joint assemblies smaller than 2" (DN50), no support is required.
4. For the loop joint assemblies bigger than 2" (DN50). If the assembly is hanged down vertically, no support is required. For other type of connections, supporting operation may be done in two different ways. For the +/- 4" (100mm) movement of loop joints, a hanger rod which is 12" (300mm) or greater will allow the loop to swing properly in order to maintain the security of the assembly. In case that the loop joint is forced to be installed with hanging rod that is shorter than recommended distance above, it is suggested to use a spring hanger. Spring type of hangers may provide the required flexibility to the assembly during seismic motions.
5. Loop joint assemblies are supplied with spreader bars to prevent misalignments during installation. This bar should be removed after installation.
6. Loop joint assembly must be cleared 4" (100mm) from all around the assembly.
7. If the loop joint assembly can't meet the building's seismic separation, it is suggested to install it with the closest elbow less than 24" (600mm) from seismic separation.
8. If the loop joint assembly is to be installed in vertically upright position (180° elbow, over the pipeline), the entrapped air should be removed.

## RUBBER EXPANSION JOINTS

Scan this QR Code

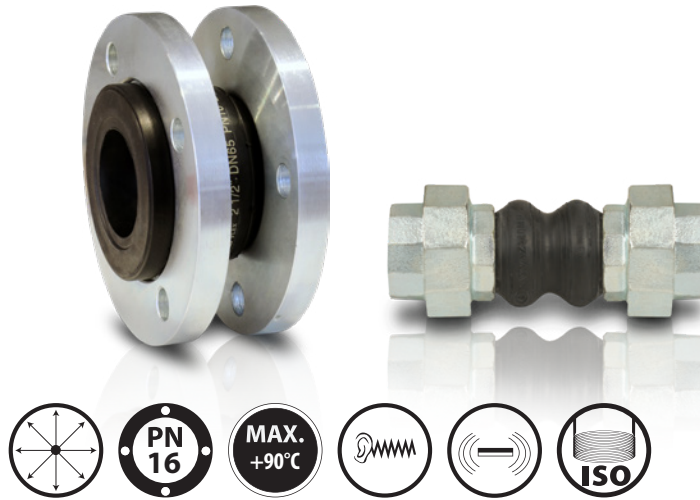

Ayvaz rubber expansion joints provide excellent compensating features by their highly rated rubber bellows which is consisted of EPDM and steel wire. They are designed to compensate axial, lateral, angular and transverse movements at the same time.

### DESIGN

Bellow Material Special Synthetic Rubber  
 Connection Types Floating Flanged, Threaded

### Operation Conditions

Nominal Diameter DN 20 (3/4") - DN 80 (3") - DKK-10  
 DN32 (1 1/4") - DN600 (24")- LKA-10  
 Operating Temperature -10°C/+90 °C  
 Operating Pressure Max. to 10 bar - It depends on the nominal diameter and the operating temperature.

### Application Areas

- Air Conditioning System
- Air ducts, chemical lines
- Circulating water lines
- Compressor lines, paper stock lines
- Pump-suction and discharge
- Refrigeration lines
- Turbine to condenser
- Not suitable for oil gasoline and greases.

### Advantages of Rubber Expansion Joints

- Excellent chemical resistance
- No fatigue due to vibrations or life cycle
- Negligible pressure loss of pipes
- Elastic material, extra safety
- Excellent wear resistance
- Excellent sound reduction

### Transport and Storage

Rubber expansion joint should be stored in dry and dark place. Avoid exposure to direct sunlight. Protect from moisture and mechanical damage. Storage temperature should not exceed -10°C and 50°C. Do not use connection holes for transport.

### Movement Absorption

- To compensate thermal expansion and compression.
- To reduce tension in the pipelines.
- To prevent noise and vibration to protect the connected systems.
- To compensate for ground, and settlement of especially the new buildings.
- To provide proper sealing with their elastic structures where the pipelines pass through walls.

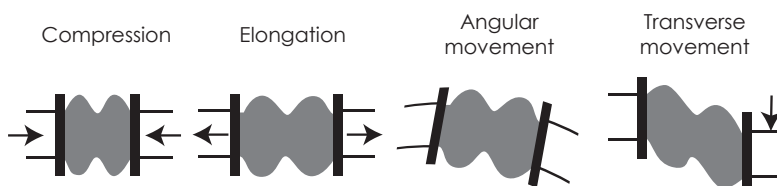

## RUBBER EXPANSION JOINTS

### Rubber Expansion Joint DKK-10

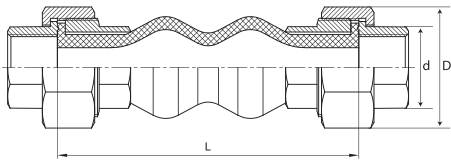

DN	Rc"	L	Axial Movement (mm)	Lateral Movement (mm)	Angular Movement (±°)	Code
DN15	1/2"	165	-22/+6	-22/+22	30°	708.150.100.010
DN20	3/4"	165	-22/+6	-22/+22	30°	708.150.100.020
DN25	1"	175	-22/+6	-22/+22	30°	708.150.100.030
DN32	1 1/4"	186	-22/+6	-22/+22	30°	708.150.100.040
DN40	1 1/2"	186	-22/+6	-22/+22	30°	708.150.100.050
DN50	2"	186	-22/+6	-22/+22	30°	708.150.100.060
DN65	2 1/2"	218	-22/+6	-22/+22	30°	708.150.100.070
DN80	3"	260	-22/+6	-22/+22	30°	708.150.100.080

\*Special designed, rubber expansion joints with customized features are available on request.

\*\* Subject to technical alterations and deviations resulting from the manufacturing process without giving any notification.

### Rubber Expansion Joint LKA-10

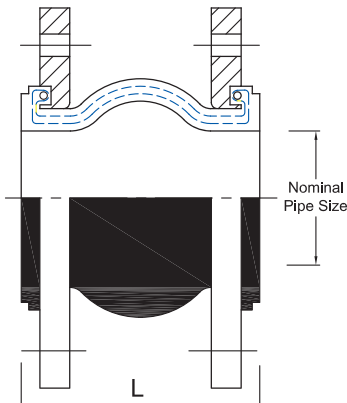
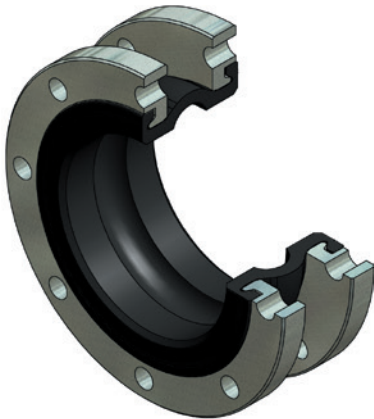

Size up to DN 300							
Nominal Pipe Size		Neutral Length L	Axial Compression	Axial Elongation	Lateral Deflection	Angular Deflection	Max. Operating Pressure
mm	inç	mm	mm	mm	+or -mm	+or -deg	bar
32	1 1/4	100	10	10	10	10	16
40	1 1/2	100	10	10	10	10	16
50	2	100	10	10	10	10	16
65	2 1/2	100	10	10	10	10	16
80	3	100	10	10	10	10	16
100	4	100	10	10	10	10	16
125	5	120	12	12	12	12	16
150	6	120	12	12	12	12	16
200	8	120	12	12	12	12	16
250	10	120	12	12	12	12	16
300	12	120	12	12	12	12	16
Size from DN 350 to DN 600							
350	14	266	25	16	18	15	10
400	16	266	20	16	18	15	10
450	18	200	20	12	18	15	10
500	20	200	20	12	18	15	10
600	24	250	20	12	18	15	10

\*Special designed, rubber expansion joints with customized features are available on request.

\*\* Subject to technical alterations and deviations resulting from the manufacturing process without giving any notification.

## INSTALLATION OF RUBBER EXPANSION JOINTS

The installation should be designed so that rubber expansion joints was not used as a support element. The pipeline should be equipped with fixed supports and sliding guides in the appropriate place. Counter flanges should be clean and free of burrs and oil and should fit the mounting area of the rubber bellow.

### Rubber Expansion Joints with Tie Rods

In case of making rubber expansion joints "restrained" Additional tie rods may be used. This would provide extra safety against fixed point failures. Diameter, material, number of the tie rods are decided by internal pressure.

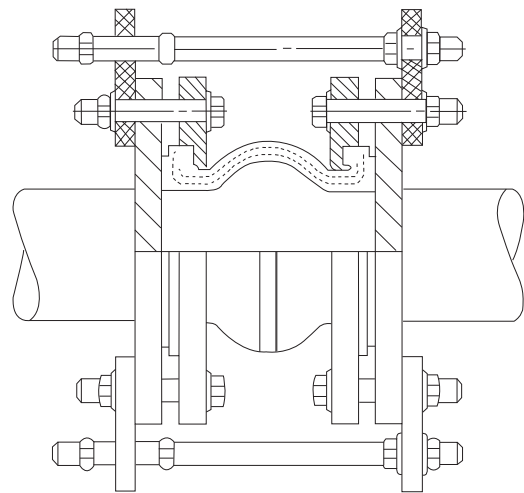

### Basic Installation Scheme

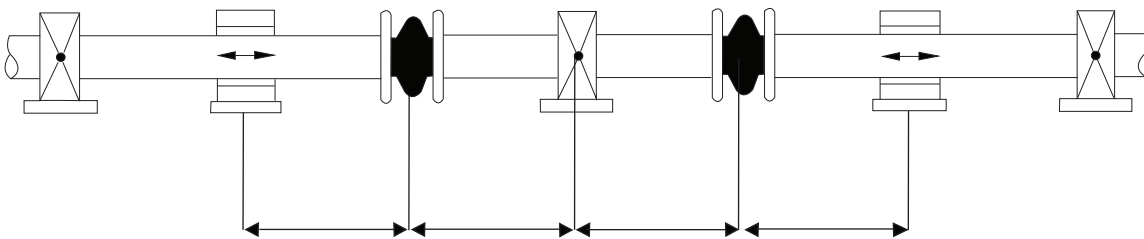

When two successive sliding support are used, the distance between them can be  $14 \times D$ , where  $D$  is the outer diameter of the pipe.

Counter flanges which the rubber expansion joints is mounted should be parallel and the distance between the rebate should be consistent with "L". The permissible deviation of the installation dimension is max.  $\pm 5\text{mm}$ .

When mounting the rubber expansion joints in the vicinity of the pump, the distance of the rubber expansion joints from the nozzle should be min.  $1.5 \times D$ .

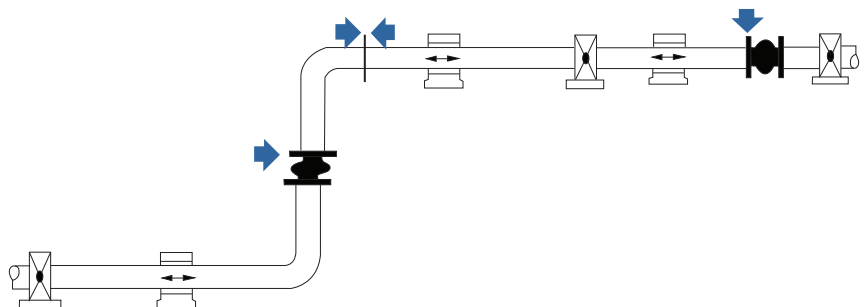

# INSTALLATION OF RUBBER EXPANSION JOINTS

## Recommendations for assembly.

Nuts should be placed on the side of counter flange.

Counter flanges should be selected specifically. Proper surface of the sealing face must coincide with the surface of the rubber expansion joints. Proper selection is shown below.

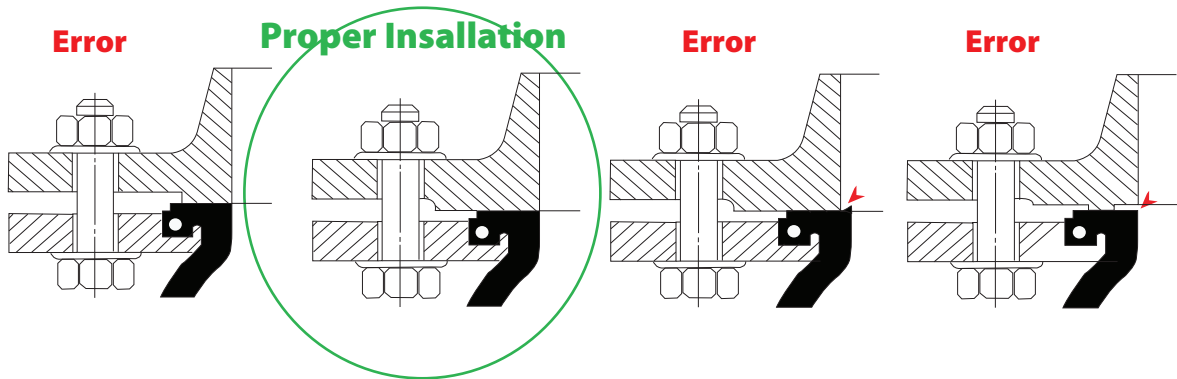
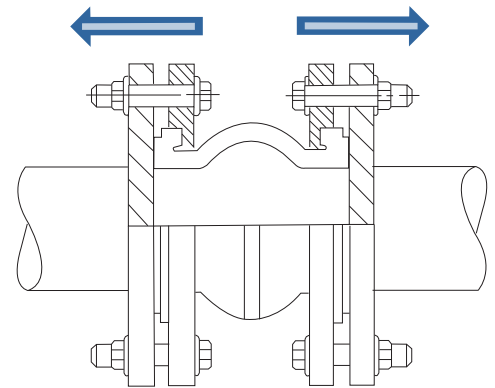

Edge of the pipe rims beyond the surface of the rebate may damage the expansion joints. The joint plane should be aligned.

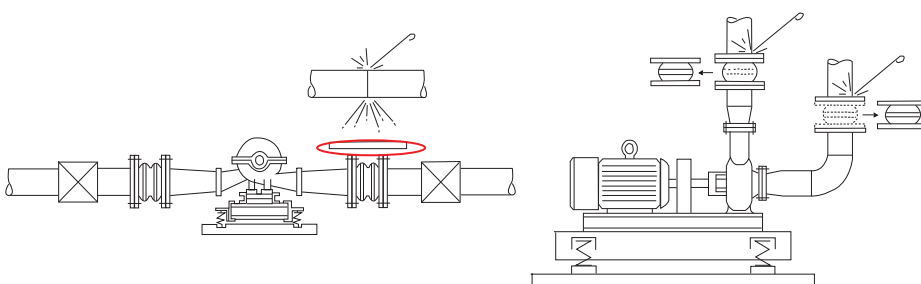
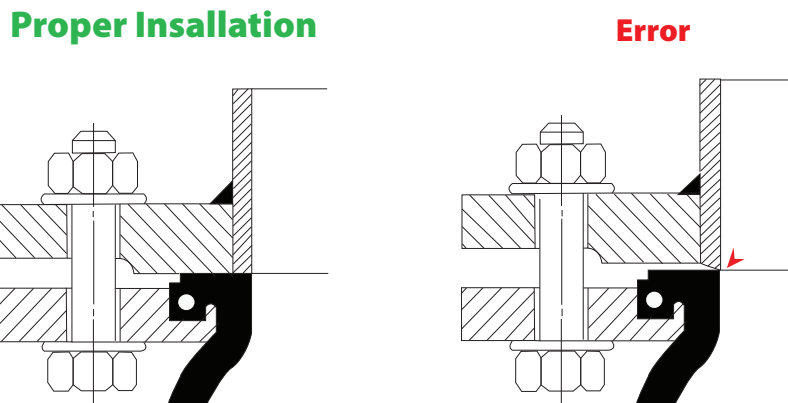

At the time of assembly you should be careful near the rubber expansion joints. In particular when grinding and welding, rubber expansion joints should be covered. Installation of rubber expansion joints may be carried out by welding of counter-flanges.



## INSTALLATION OF RUBBER EXPANSION JOINTS

In case of installation outside of the building, where the rubber expansion joints is exposed to direct sunlight the permanent cover should be provided.

### Rubber Expansion Joints must not be isolated.

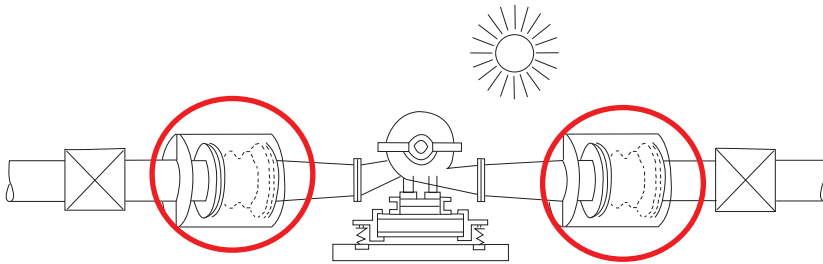

Immediately prior to installation, clean the contact surface of the rubber expansion joints and counter flange from the mechanical impurities degrease them and remove the remaining paint if needed.

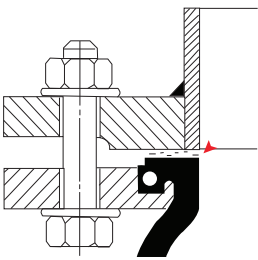

The first step is to tighten the screws by hand and the other two passages should be performed using a torque wrench. This will prevent the destruction of the sealing surface.

### Service and Repair

Periodically inspect rubber expansion joints. The first inspection should take place a week after the start-up and subsequent ones in cycles set by the user but not less frequently than once a year. Particular attention should be paid to external damage of the rubber expansion joints, such as blisters, cracks and leaks and its deformation. Please check unacceptable displacements and changes in the length of the installation, as well as corrosion and wear the assembly.

For cleaning the rubber expansion joint do not use any sharp-edged objects, wire brushes or abrasive paper. Cleaning of the rubber expansion joints should be carried out with clean water and soap with a weak alkaline pH.

**It is forbidden to perform actions within the rubber expansion joint (loosening the fixing screws on the flanges) when the system is under pressure.**

**INSTALLATION OF RUBBER EXPANSION JOINTS**

**DKK-10 Pump Outlet (Vibration Absorbtion)**

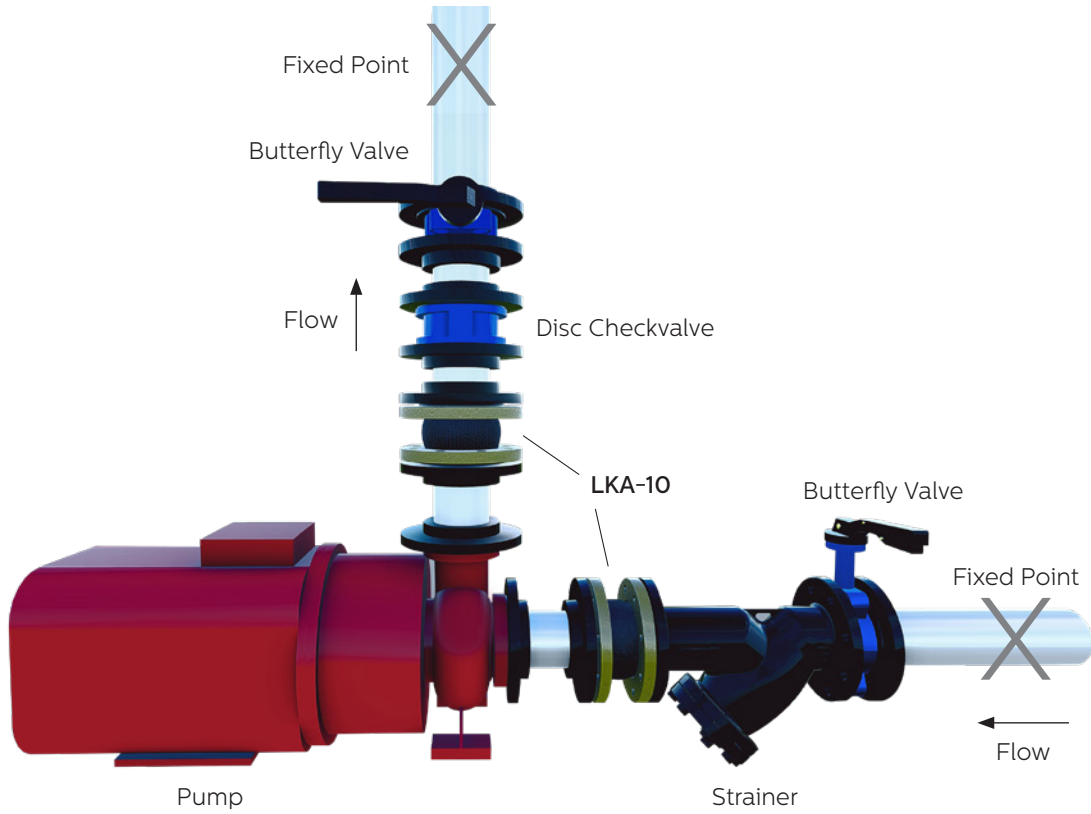

**DKK-10 Pump Outlet (Vibration Absorbtion)**

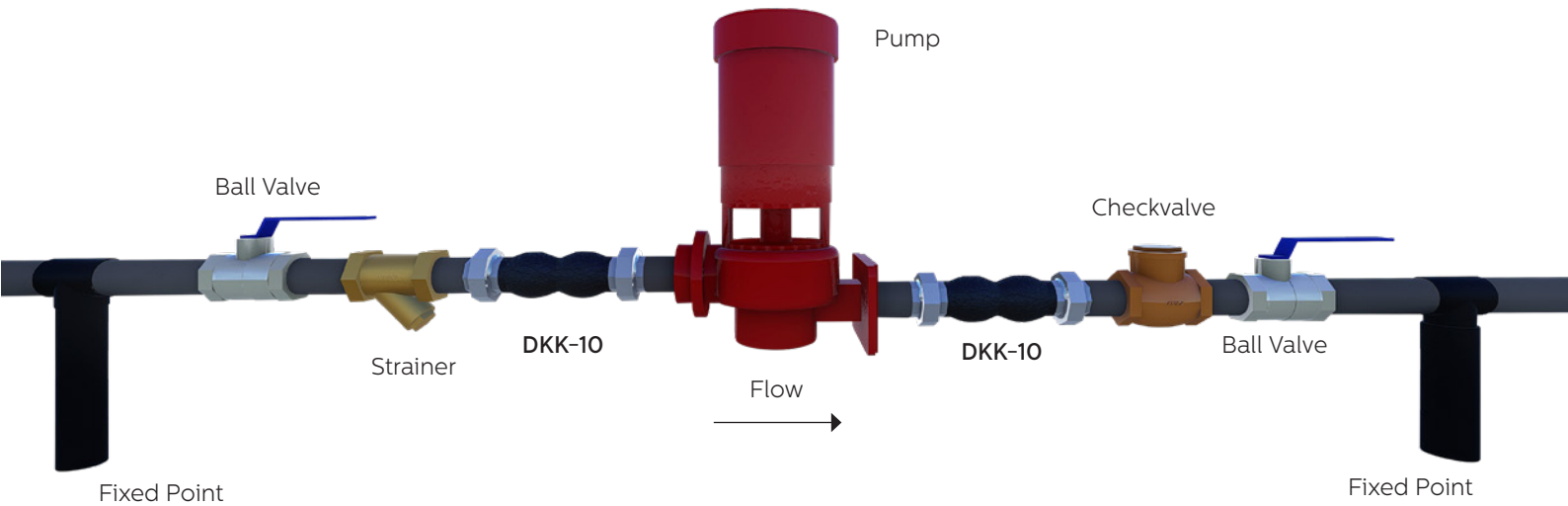

# EXPANSION JOINTS PRODUCTS



## HEAD OFFICE - FACTORY

Atatürk Sanayi Bölgesi Hadımköy Mahallesi  
Mustafa İnan Caddesi No: 44 Arnavutköy - İSTANBUL  
Tel: +90 212 771 01 45 (pbx) | Fax: +90 212 771 47 27

**Cona  
Caserta/Italy**  
Tel: +39 0823 187 3988  
rmolaro@ayvaz.com

**Ayvaz Germany  
Viernheim/Germany**  
Tel: +49 62046014399  
germany@ayvaz.com

**Tricorr  
Warsaw/Poland**  
Tel: +48-32-783-295-1  
tricorr@tricorr.eu

**Ayvaz N  
Isperih/Bulgaria**  
Tel: +359 8431 27 32  
office@ayvaz-n.eu

**Haci Ayvaz M.E.  
Dubai/U.A.E**  
Tel: +971 563550822  
+971 501306871  
mideast@ayvaz.com

**Ayvaz Baku  
Baku/Azerbaijan**  
Tel: +99(455) 579-84-32  
ahayatov@ayvaz.com

info@ayvaz.com | www.ayvaz.com

**Ayvaz Ukraine  
Kiev/Ukraine**  
Tel: +380 44 390 57 57  
info@ayvaz.com.ua

**Ayvaz China  
Jinan/China**  
Tel: +86 0574 5897 3851  
info@ayvazchina.com

**Ayvaz Serbia  
Belgrade/Serbia**  
Tel: +381 61 658 70 52  
yakbiyik@ayvaz.com

**Ayvaz Kazakhstan LLP  
Almaty/Kazakhstan**  
Tel: +7 (727) 327 97 57  
info\_kz@ayvaz.com  
www.ayvaz.kz

**Ayvaz Vietnam HCMC/  
Vietnam**  
ggursoy@ayvaz.com  
Tel: +84 89 8508345

FLEXIBLE SOLUTIONS  
FOR INDUSTRY